



eManager

SMART ENERGY CONTROLLER

USER MANUAL



Preface

Thank you for choosing SAJ products. We are pleased to provide you first-class products and exceptional service.

This manual provides information about installation, operation, maintenance, troubleshooting and safety. Please follow the instructions of this manual so that we can ensure delivery of our professional guidance and whole-hearted service.

Customer-orientation is our forever commitment. We hope this document proves to be of great assistance in your journey for a cleaner and greener world.

We make constant improvements on the products and their documentation. This manual is subject to change without notice; these changes will be incorporated in new editions of the publication. To access the latest documentation, visit the SAJ website at <https://www.saj-electric.com/>.

Guangzhou Sanjing Electric Co., Ltd.



TABLE OF CONTENTS

1.	About this Document	1
1.1.	Application scope.....	1
1.2.	Safety.....	1
1.3.	Safety levels.....	1
1.4.	Symbol explanation.....	2
1.5.	Safety instructions.....	3
1.6.	Safe handling.....	3
2.	Product Information.....	4
2.1.	Application topology diagram.....	4
2.2.	Main features.....	4
2.3.	Package contents.....	5
2.3.1.	eManager.....	5
2.3.2.	Pro-Mate.....	6
2.4.	Product dimension.....	6
2.4.1.	eManager.....	6
2.4.2.	AC-DC power supply module.....	7
2.4.3.	Pro-Mate module.....	7
2.5.	Upper view.....	8
2.6.	Bottom view.....	9
2.7.	LED indicators.....	11
2.8.	Product specifications.....	12
3.	Installation.....	13
3.1.	Install the eManager.....	13
3.2.	(Optional) Install the AC-DC power supply module.....	16
4.	Electrical Connection.....	18
4.1.	Connect devices to the EMS.....	18
4.1.1.	Scenario: inverter quantity = 1.....	20



4.1.2.	Scenario: inverter quantity ≥ 2 (paralleling connection)	28
4.2.	(Optional) Connect the heat pump to the EMS	37
4.3.	(In Australia and New Zealand) DRM connection	37
4.4.	(In Germany) RCR connection	38
5.	Firmware Update (Optional)	39
5.1.	Remote upgrade (Web platform)	40
5.2.	Local Upgrade (Web page and App) (Bluetooth connection)	47
5.3.	Operations After the upgrade	50
6.	Commissioning by the App	51
6.1.	Install the App	51
6.2.	Log in to the App	51
6.3.	Perform the initialization settings	53
6.4.	View the EMS settings	66
6.5.	Set the dry contact function	69
6.6.	View the inverter firmware version	74
6.7.	Create a plant	75
7.	Appendix	78
7.1.	Recycling and disposal	78
7.2.	Warranty	78
7.3.	Contacting support	78
7.4.	Trademark	78



1. About this Document

1.1. Application scope

This user manual provides instructions and detailed procedures for installing, operating, and maintaining the SAJ product:

- eManager
- eManager-Pro (eManager with a Pro-Mate module)

1.2. Safety

CAUTION:

ONLY qualified and trained electricians who have read and fully understood all safety regulations contained in this manual can install, maintain, and repair the equipment. Access to the equipment is by the use of a tool, lock and key, or other means of security.

1.3. Safety levels







 DANGER
Indicates a hazardous situation which, if not avoided, will result in death or serious injury.

 WARNING
Indicates a hazardous situation which, if not avoided, could result in death or serious injury.

 CAUTION
Indicates a hazardous condition which, if not avoided, could result in minor or moderate injury.

 NOTICE
Indicates a situation which, if not avoided, can result in property damage.

1.4. Symbol explanation

Symbol	Description
	Dangerous electrical voltage This device is directly connected to public grid, thus all work to the device shall only be carried out by qualified personnel.
	No open flames Do not place or install near flammable or explosive materials.
	Attention: Install the product out of reach of children.
	This device shall NOT be disposed of in residential waste.
	CE Mark Equipment with the CE mark fulfills the basic requirements of the Guideline Governing Low-Voltage and Electro-magnetic Compatibility.
	Recyclable
	Avoid liquid or moisture



1.5. Safety instructions

Keep the manual for future reference.

To prevent personal injury and property damage and to ensure long-term operation of the product, be sure to read all the safety instructions in this section carefully prior to any works and observe the appropriate rules and regulations of the country or region where you install the device.

1.6. Safe handling

The product has been designed and tested strictly in accordance with international safety regulations. As an electrical and electronic equipment, it must be installed, commissioned, operated, and maintained in strict accordance with related safety instructions. Incorrect operation or misuse of this device may cause personal injury or device damage. This will void the limit warranty and SAJ will not be responsible for the loss caused by those behaviors.

- The eManager must be installed and maintained by authorized technicians based on local laws and regulations.
- Before installing or maintaining the eManager, make sure that it is disconnected from the grid.
- When the eManager is working, do not touch the internal component or cable to avoid electric shock.
- Before replacing an internal component within the eManager, make sure that the eManager is disconnected from the grid and the new component meets the usage requirement.
- When the eManager is working, do not plug in or out the cables.
- Make sure that the AC input voltage and current are compatible with the rated voltage and current of the eManager; otherwise, components might be damaged, or the device cannot work properly.

2. Product Information

2.1. Application topology diagram

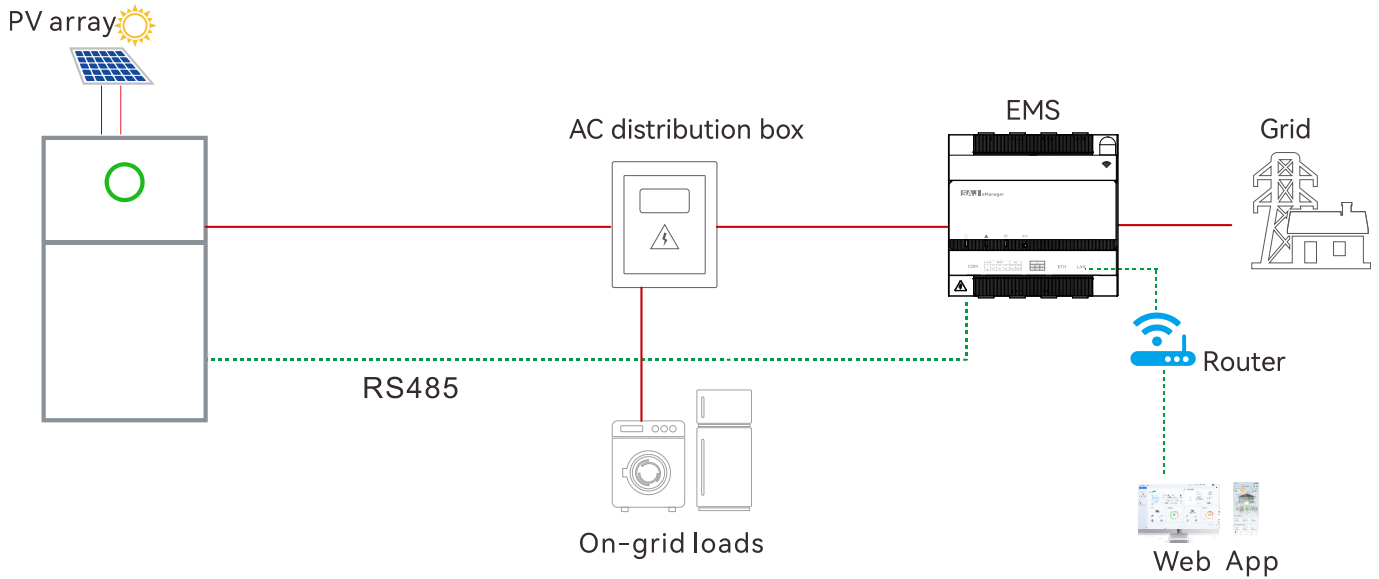

2.2. Main features

SAJ eManager smart communication device (hereinafter called the eManager) is applied to the photovoltaic (PV) energy storage system (ESS). It can:

- Manage Energy scheduling: schedule the energy to the loads, batteries, and the grid based on user requirements.
- Provide same functions as the smart meter: power monitoring and energy metering.
- Collect and transmit data of inverters, batteries, and other equipment.

In addition, it provides the following functions:

- Smart and flexible support
 - Support for RS485, Ethernet, Wi-Fi, and Bluetooth communication
 - Support for communication and monitoring on a maximum of six hybrid inverters or ten solar inverters
- Convenient operation and maintenance

- Easy installation
- 24-hour local and remote monitoring
- Remote operation: PV-plant maintenance on App or Web

Working with the Pro-Mate module, SAJ eManager-Pro provides extra support:

- Demand response mode (DRM) connection in Australia and New Zealand
- Ripple control receiver (RCR) connection in Germany
- 4G communication

Working with the AC-DC power supply module, if the eManager needs to work during the off-grid time, the ESS can provide the power supply to the eManager.

2.3. Package contents

2.3.1. eManager

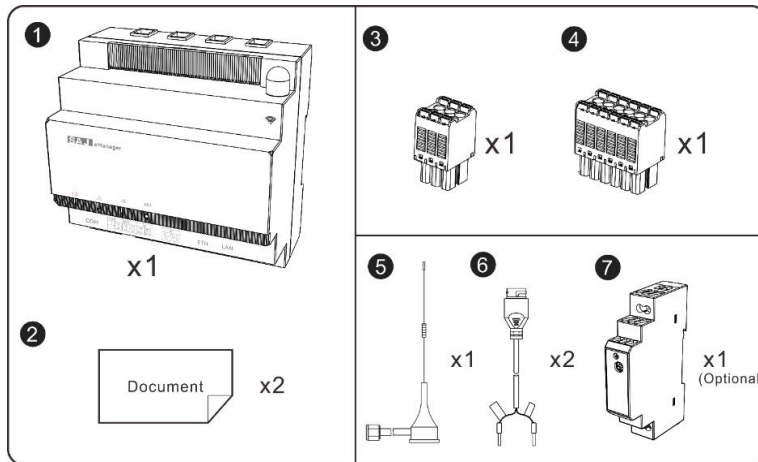

Callout	Description	Quantity	Callout	Description	Quantity
1	eManager	1	2	Quick Guide	1
3	6-pin connector	1	4	12-pin connector	1
5	Antenna	1	6	Communication cable	2
7	AC-DC power supply module (optional)	1	/	/	/

2.3.2. Pro-Mate

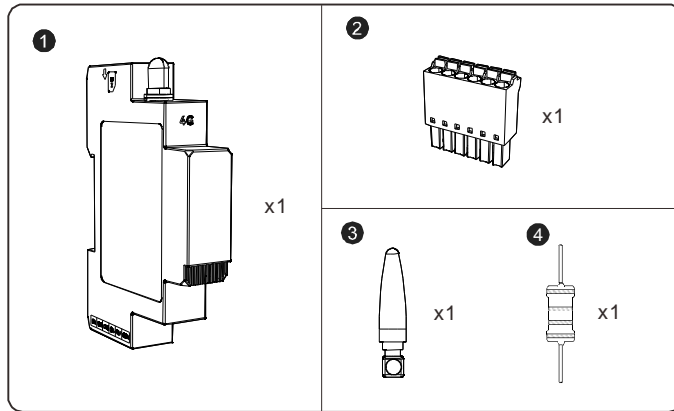

Callout	Description	Quantity	Callout	Description	Quantity
①	Pro-Mate	1	②	6-pin connector	1
③	Antenna	1	④	15 kΩ resistance	1

2.4. Product dimension

2.4.1. eManager

Height x Width x Depth (mm): 105.4 x 108 x 67

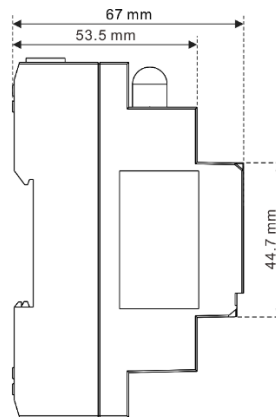
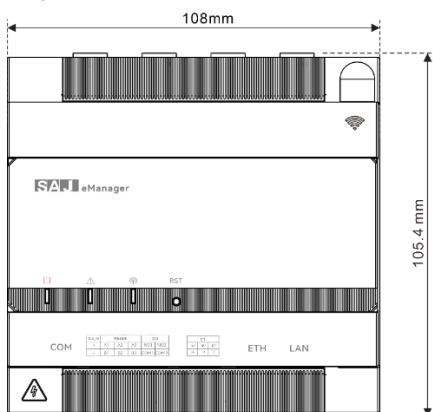

2.4.2. AC-DC power supply module

Height x Width x Depth (mm): 90 x 17.6 x 58

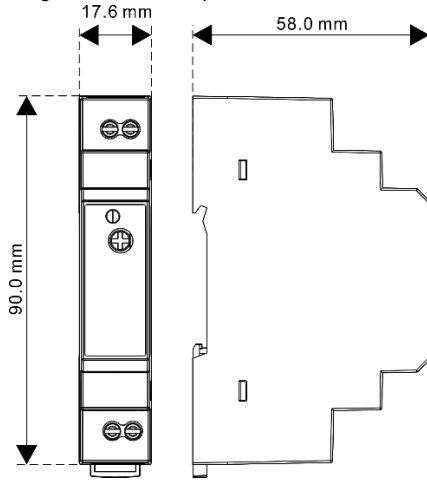

2.4.3. Pro-Mate module

Height x Width x Depth (mm): 102.5 x 18.6 x 66.5

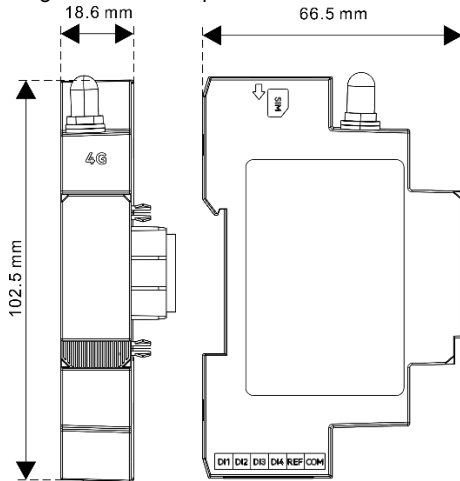

2.5. Upper view

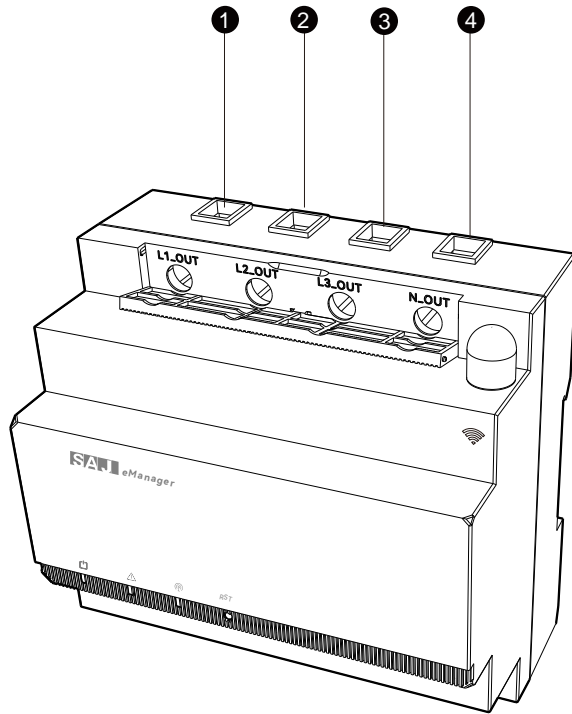

Callout	Name	Description
①	L1_OUT	ONLY applicable in internal CT connection scenario. For connecting the AC power cable for grid phase L1 and supplying power to loads.
②	L2_OUT	ONLY applicable in internal CT connection scenario. For connecting the AC power cable for grid phase L2 and supplying power to loads.
③	L3_OUT	ONLY applicable in internal CT connection scenario. For connecting the AC power cable for grid phase L3 and supplying power to loads.
④	N_OUT	ONLY applicable in internal CT connection scenario. For connecting the AC power cable for grid phase N and supplying power to loads.

2.6. Bottom view

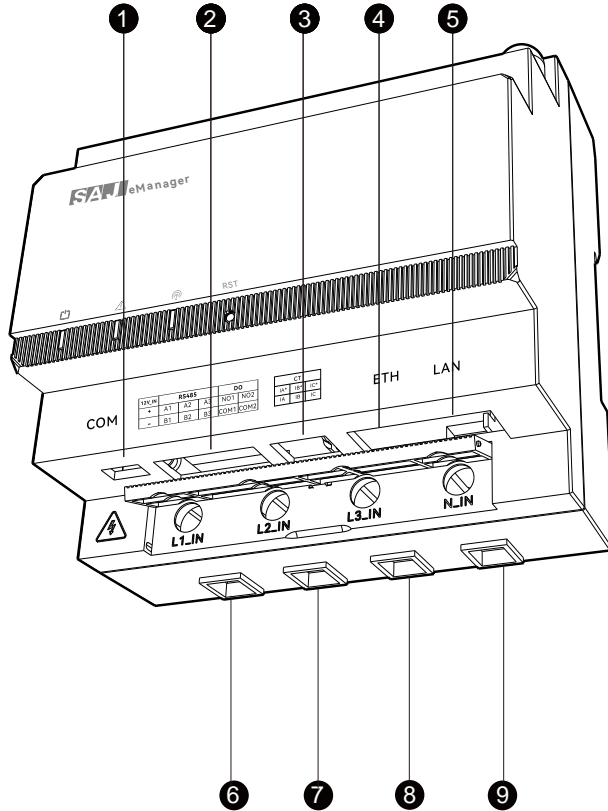

Callout	Name	Description
1	COM	For debugging in maintenance.
2	12V_IN+ and 12V_IN-	Input ports for eManager backup power supply. For connecting to the DC output of the AC-DC power supply module.
	RS485 A1 and RS485 B1 RS485 A2 and RS485 B2 RS485 A3 and RS485 B3	For communication with the inverter(s). Notes: <ul style="list-style-type: none"> You can use any pair of RS485 port combination to connect to the inverter(s). For optimal performance, one pair of RS485 port combination supports a maximum of two inverters.

	DO NO1 and DO COM1 DO NO2 and DO COM2	For connecting the DI terminals of external devices, so as to control the startup and shutdown of the connected external devices.
③	CT IA* and CT IA CT IB* and CT IB CT IC* and CT IC	For connecting the wires of three CTs. Note: The asterisk (*) symbol indicates the positive wire of the CT.
④	ETH	To connect to the router for data transmission in Ethernet network configuration mode
⑤	LAN	For Modbus TCP communication. Note: For the supported devices, refer to the LAN communication connection diagrams in sections 4.1.1 and 4.1.2.
⑥	L1_IN	AC power cable input for grid phase L1
⑦	L2_IN	AC power cable input for grid phase L2
⑧	L3_IN	AC power cable input for grid phase L3
⑨	N_IN	AC power cable input for grid phase N

2.7. LED indicators

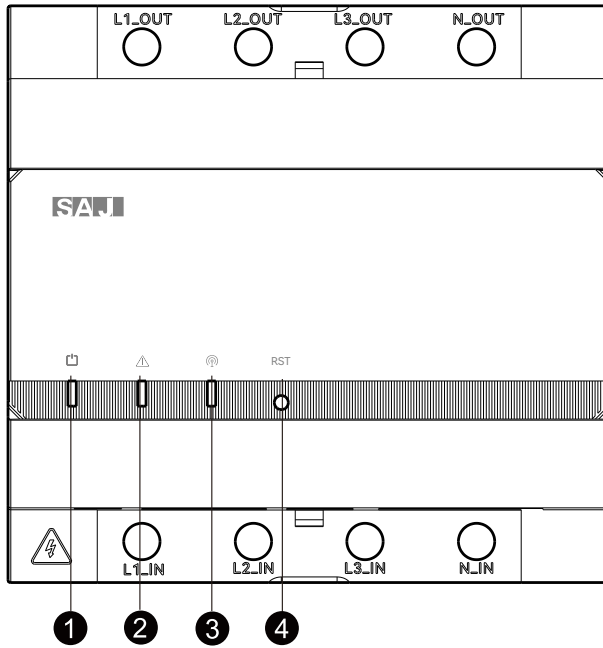

LED and button	Status	Color	Description
❶ Power status LED	On	Green	The eManager is powered on.
	Off	None	The eManager is powered off.
❷ Fault LED	On	Red	An error has occurred.
	Off	None	The eManager is working properly.
❸ Communication status LED	Blinking	Green	The eManager is connected to the monitoring platform.
	Off	None	The eManager is not connected to the monitoring platform.
❹ Reset button	/	/	You can use a clip to press the button to reset the system.



2.8. Product specifications

General parameters	
Application	Home usage
Communication	Bluetooth, Ethernet, Wi-Fi, RS485
Data collection interval (Min)	5 by default
Firmware update	Remote or local (Bluetooth) update
Data access	App or Web
Electrical parameters	
Input AC voltage	96 – 264 V AC
Input DC voltage	12 V DC
Input frequency	50/60 Hz
Max. power	3 W
Nominal current/limiting current per line conductor	63 A
Max. switching current of DO ports	4 A
Max. switching voltage of DO ports	250 V AC
Max. switching power of DO ports	125 VA / 120 W
Operating temperature range	-25°C to +40°C (-13°F to +104°F)
Storage temperature range	-25°C to +70°C (-13°F to +158°F)
Ambient humidity	0% – 95% (non-condensing)
Dimension (H x W x D) (mm)	105 x 108 x 67
Weight (g)	500
Ingress protection	IP20
Mounting	Rail-mounted
Warranty	Three years

3. Installation

About this task

The eManager, Pro-Mate module, and AC-DC power supply module need to be installed inside the AC distribution box.

Before you start

- Make sure that the AC distribution box meets the requirements:
 - It has a surge protective device configured.
 - It must be locked by a tool for safety, so that it cannot be opened easily.
- Make sure that the length of the rail meets the requirement:
 - If only the eManager needs to be installed, the length of the rail is not less than 108 mm.
 - If the AC-DC power supply module needs to be installed with the eManager, the length of the rail is not less than 126 mm. Alternatively, the module can be installed in another rail inside the AC distribution box.

3.1. Install the eManager

Procedure

Step 1. (Optional) Install the Pro-Mate module.

- a. Remove the port cover on the left side of the eManager.

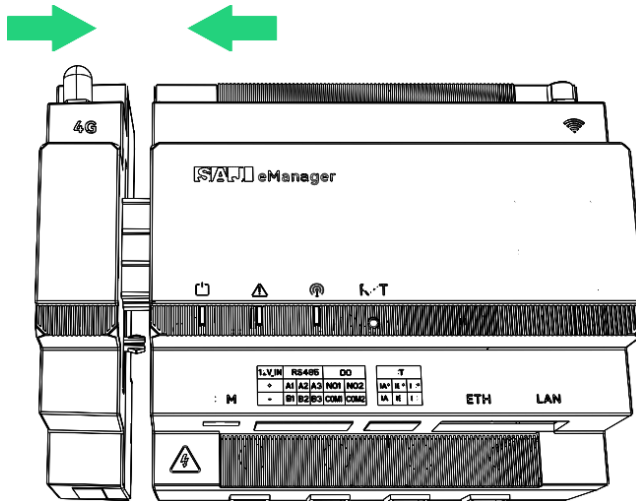

Step 2. Install the eManager to the rail.

- a. Insert the lower side of the rail into the lower slot on the back of the eManager. Push the eManager upwards until it is secured to the rail.
- b. Pivot the eManager until the upper side of the rail is inserted into the upper slot of the eManager.

eManager

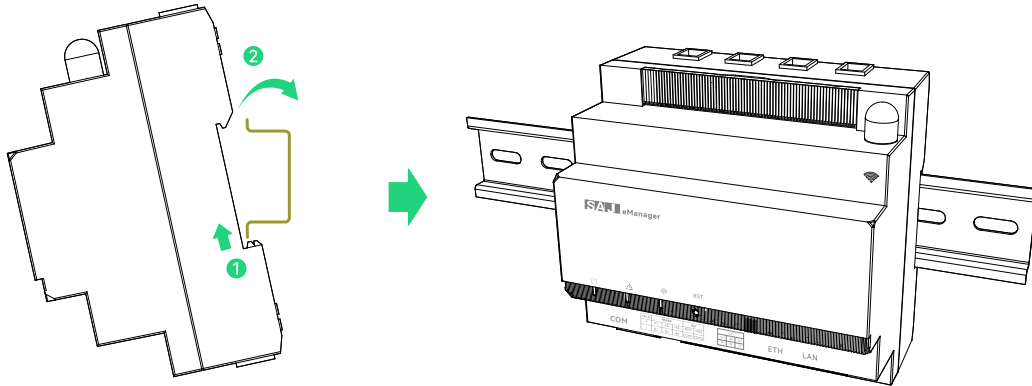

eManager-Pro

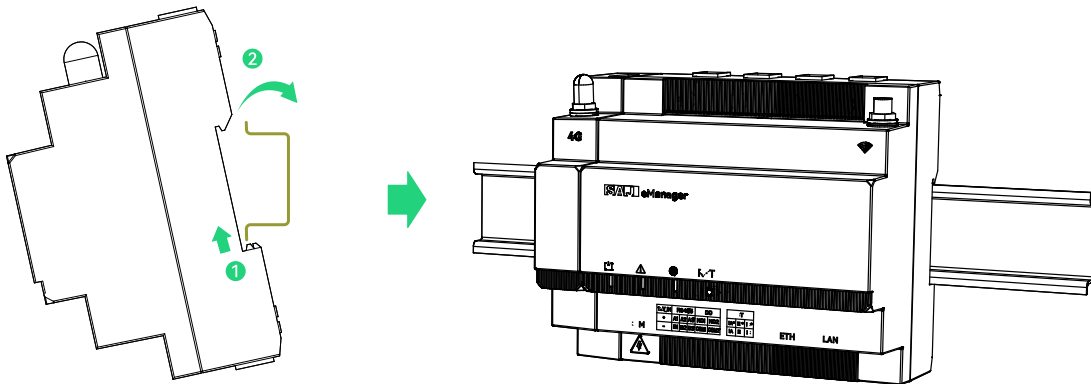

- Step 3. Install the antenna to the eManager.
- Remove the stud cap on the upper right corner of the eManager.
 - Install the antenna to the stud and tighten it.

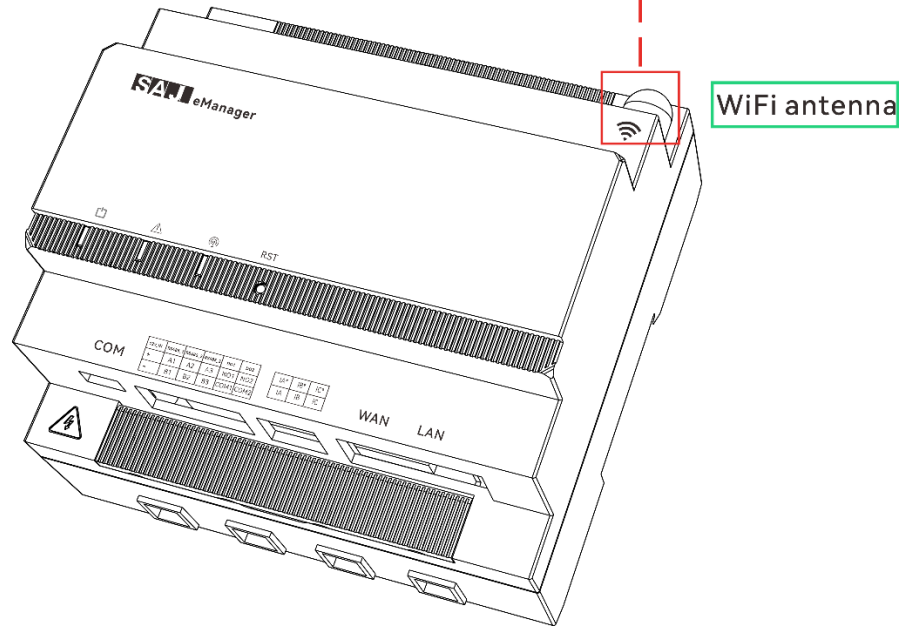
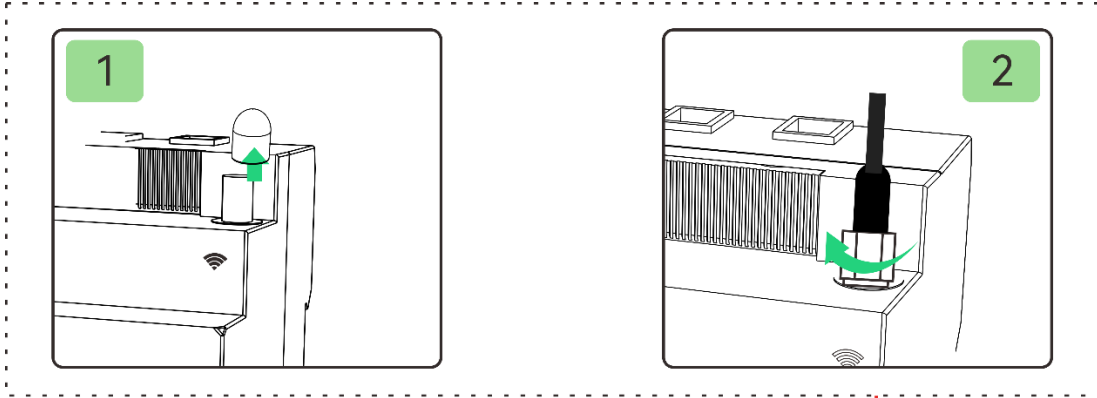



3.2. (Optional) Install the AC-DC power supply module

This module is required if the eManager needs to work during the off-grid time. By using this module, the ESS can provide the power supply to the eManager during off-grid time.

Procedure

Step 1. Install the AC-DC power supply module to the eManager or eManager-Pro.

Here takes the eManager-Pro as an example:

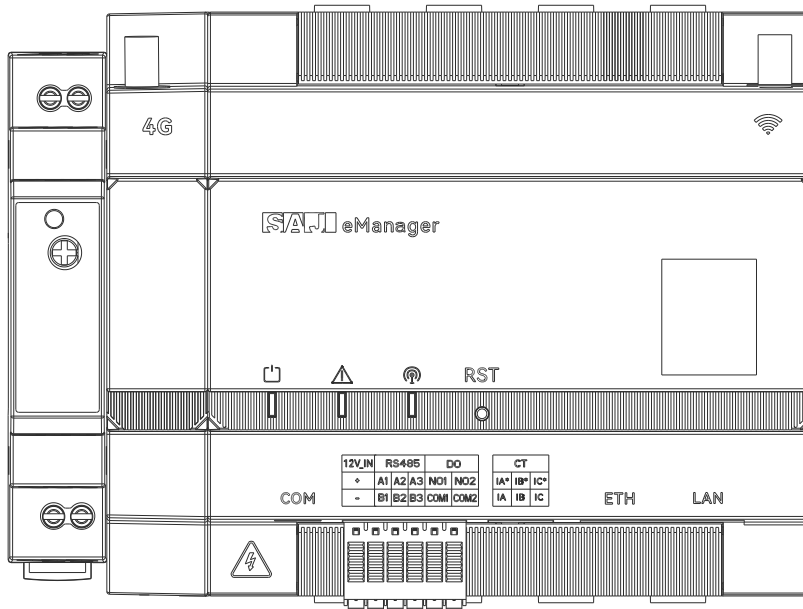

Step 2. Install the AC-DC power supply module to the rail.

- a. Pull the tab at the bottom of the module downwards.
- b. Insert the upper side of the rail into the upper slot on the back of the module.
- c. Pivot the module until the lower side of the rail is inserted into the lower slot of the module.
- d. Push the tab at the bottom of the module upwards to secure module to the rail.

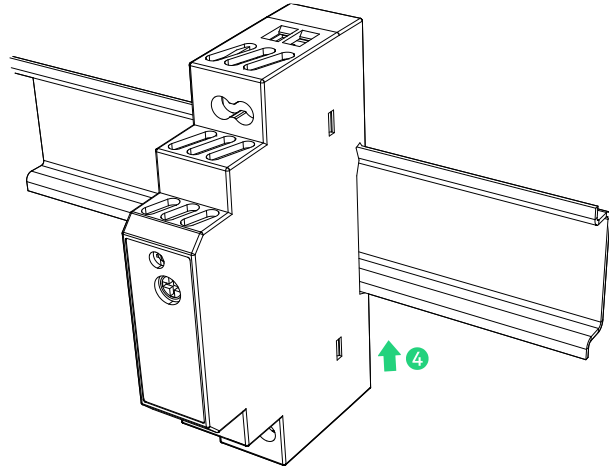
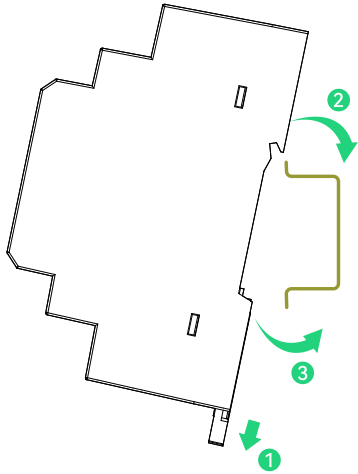



4. Electrical Connection

4.1. Connect devices to the EMS

The following two items are illustrated in the system connection diagrams in section 4.1 as examples. You can choose whether to connect them per your actual needs.

- Connection to the AC-DC power supply module (optional)

This module is only required if the eManager needs to work during the off-grid time.

The cables are connected to the ports on the AC-DC power supply module, inverter, and eManager, as listed below:

From	To
AC input of the AC-DC power supply module	BACKUP port on the inverter (any phase in three-phase grid connection)
DC output of the AC-DC power supply module	12V_IN port of the eManager Note: To locate the 12V_IN port, refer to 2.6 "Bottom view".

- Ethernet connection to the router (optional)

From	To
ETH port on the eManager Note: To locate the ETH port, refer to section 2.6 "Bottom view".	LAN port the router

You can change the communication manner to one of the followings:

- Wi-Fi connection manner to the router: The network name must be composed by letters and alphanumeric characters only, without any special characters.
- 4G communication connection: It can be used only when the Pro-Mate module is installed.



Depending on your inverter model(s) and system connection scenario, choose one of the following connection manners:

Inverter models	Scenario	
	Inverter quantity = 1	Inverter quantity ≥ 2 (paralleling)
H2-(3K-6K)-S2	Section 4.1.1.1 "Single-phase grid, internal CT connection, RS485 communication manner" Section 4.1.1.2 "Single-phase grid, external CT connection, RS485 communication manner"	Section 4.1.2.1 "Single-phase grid, internal CT connection (current ≤ 63 A), RS485 communication connection" Section 4.1.2.2 "Single-phase grid, external CT connection (current > 63 A), RS485 communication connection"
HS2-(3K-6K)-S2		
R5-(0.7K-3K)-S1		
R5-(3K-8K)-S2		
R6-(5K-10K)-(S2, S3)		
H2-(5K-10K)-T2	Section 4.1.1.3 "Three-phase grid, internal CT connection, RS485 communication manner" Section 4.1.1.4 "Three-phase grid, external CT connection, RS485 communication manner"	Section 4.1.2.3 "Three-phase grid, internal CT connection (current ≤ 63 A), RS485 communication connection" Section 4.1.2.4 "Three-phase grid, external CT connection (current > 63 A), RS485 communication connection"
HS2-(5K-10K)-T2		
R6-(5K-15K)-T2		
R6-(15K-50K)-(T2, T3, T4)		
HS3-(3K-6K)-S2	Section 4.1.1.5 "Single-phase grid, internal CT connection, LAN communication manner"	Section 4.1.2.5 "Single-phase grid, internal CT connection (current ≤ 63 A), LAN communication connection"
	Section 4.1.1.6 "Single-phase grid, external CT connection, LAN communication manner"	Section 4.1.2.6 "Single-phase grid, external CT connection (current > 63 A), LAN communication connection"
HS3-(5K-12K)-T2	Section 4.1.1.7 "Three-phase grid, internal CT connection, LAN communication manner"	Section 4.1.2.7 "Three-phase grid, external CT connection (current ≤ 63 A), LAN communication connection"
H2-(10K-30K)-(T2, T3)	Section 4.1.1.8 "Three-phase grid, external CT connection, LAN communication manner"	Section 4.1.2.8 "Three-phase grid, external CT connection (current > 63 A), LAN communication connection"

4.1.1. Scenario: inverter quantity = 1

4.1.1.1. Single-phase grid, internal CT connection, RS485 communication manner

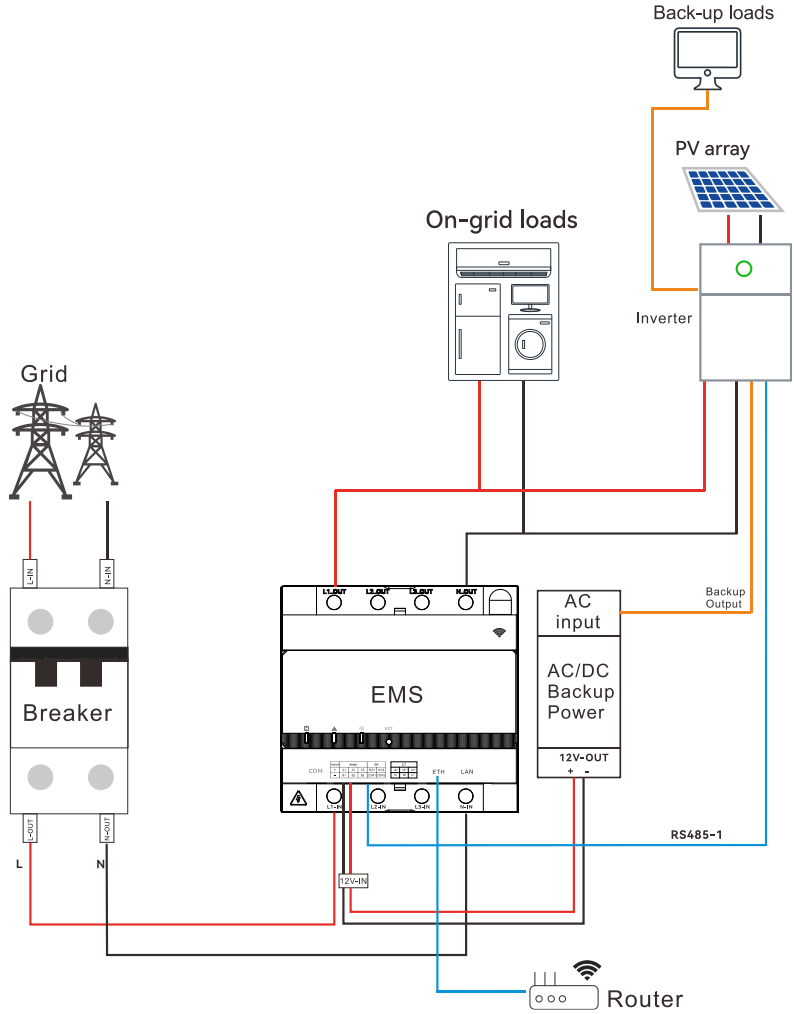

4.1.1.2. Single-phase grid, external CT connection, RS485 communication manner

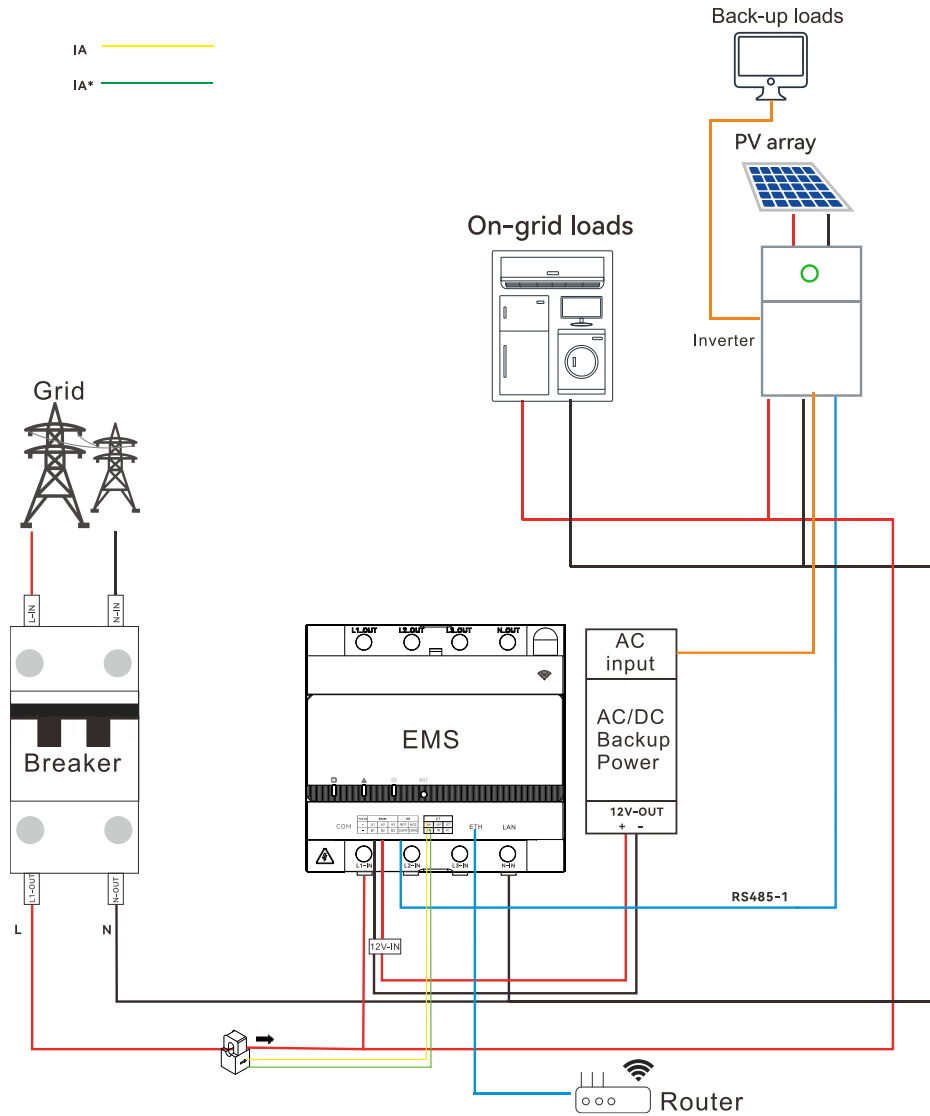

4.1.1.3. Three-phase grid, internal CT connection, RS485 communication manner

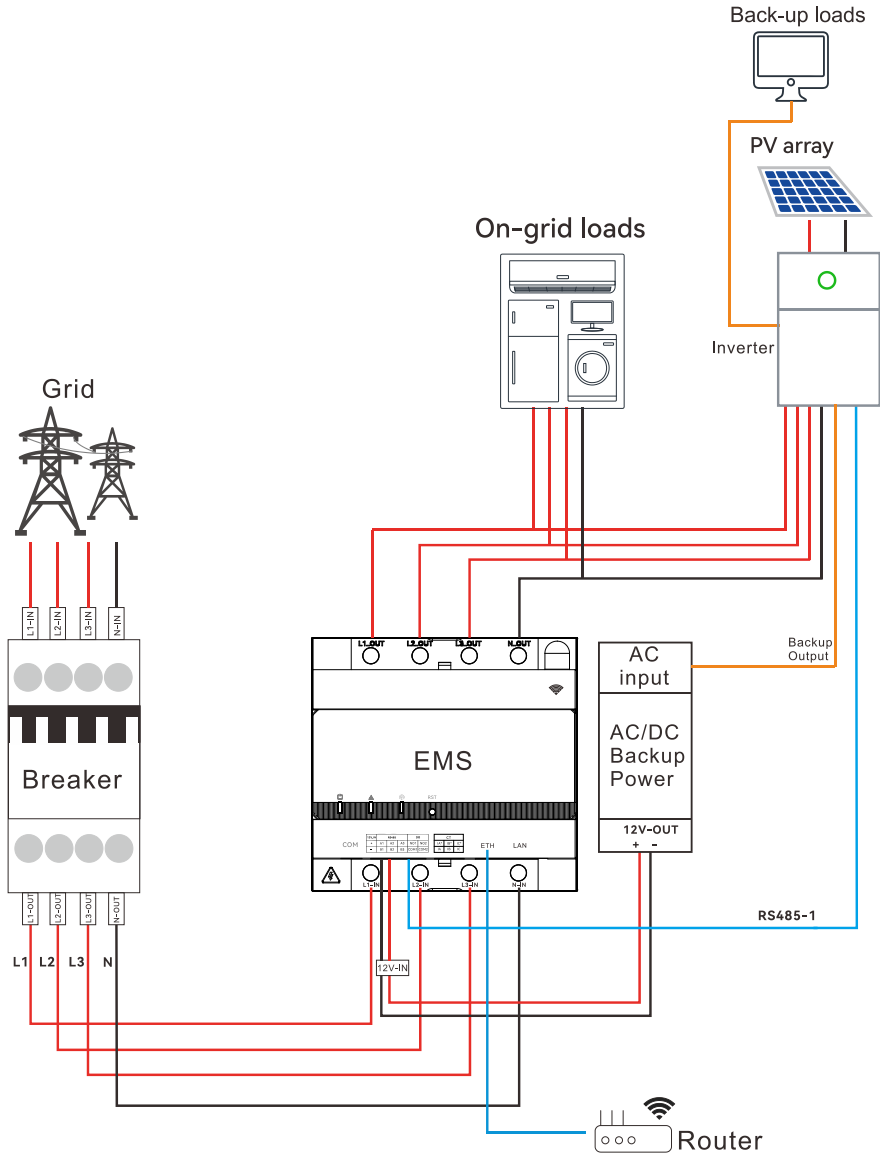

4.1.1.4. Three-phase grid, external CT connection, RS485 communication manner

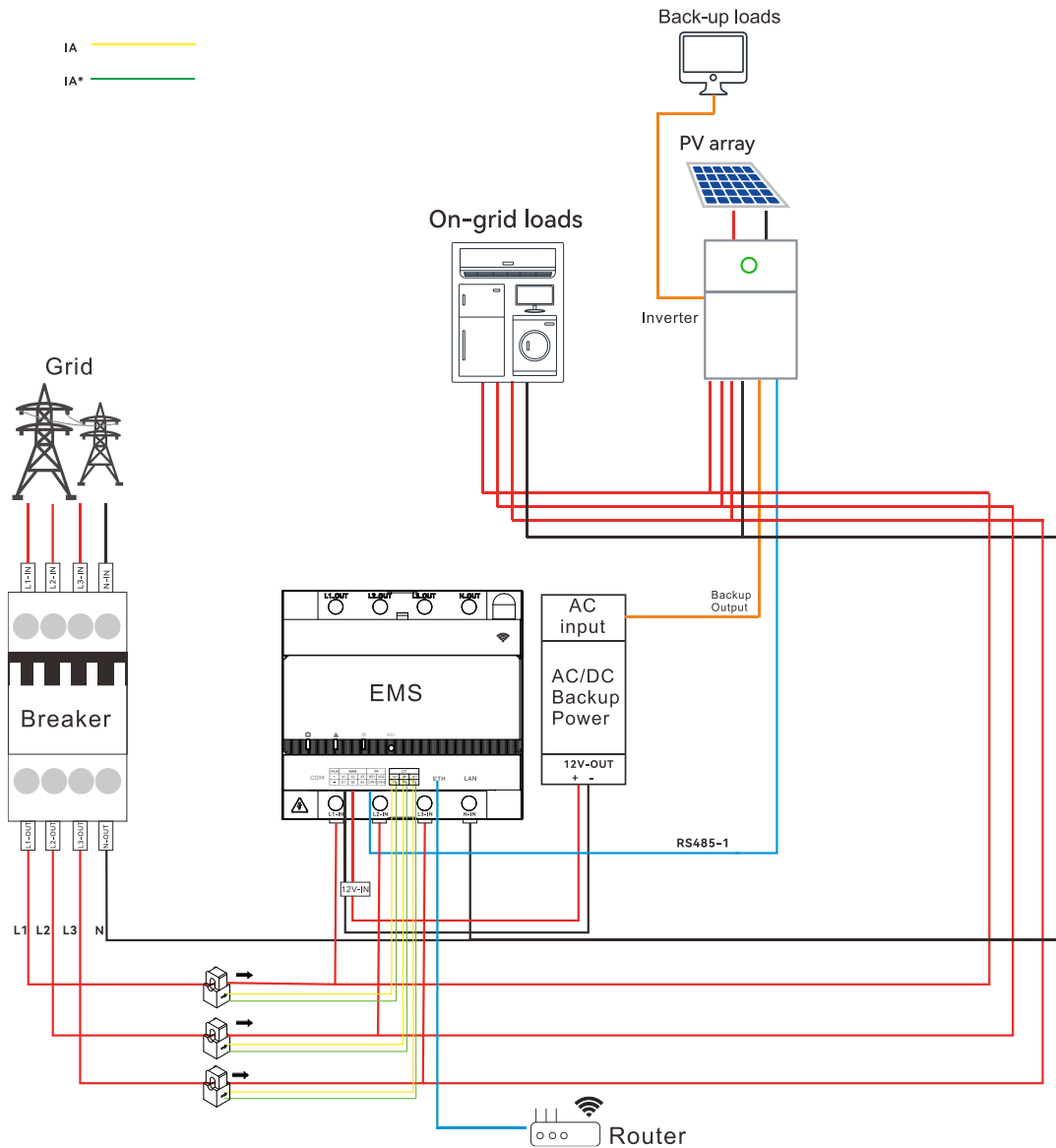

4.1.1.5. Single-phase grid, internal CT connection, LAN communication manner

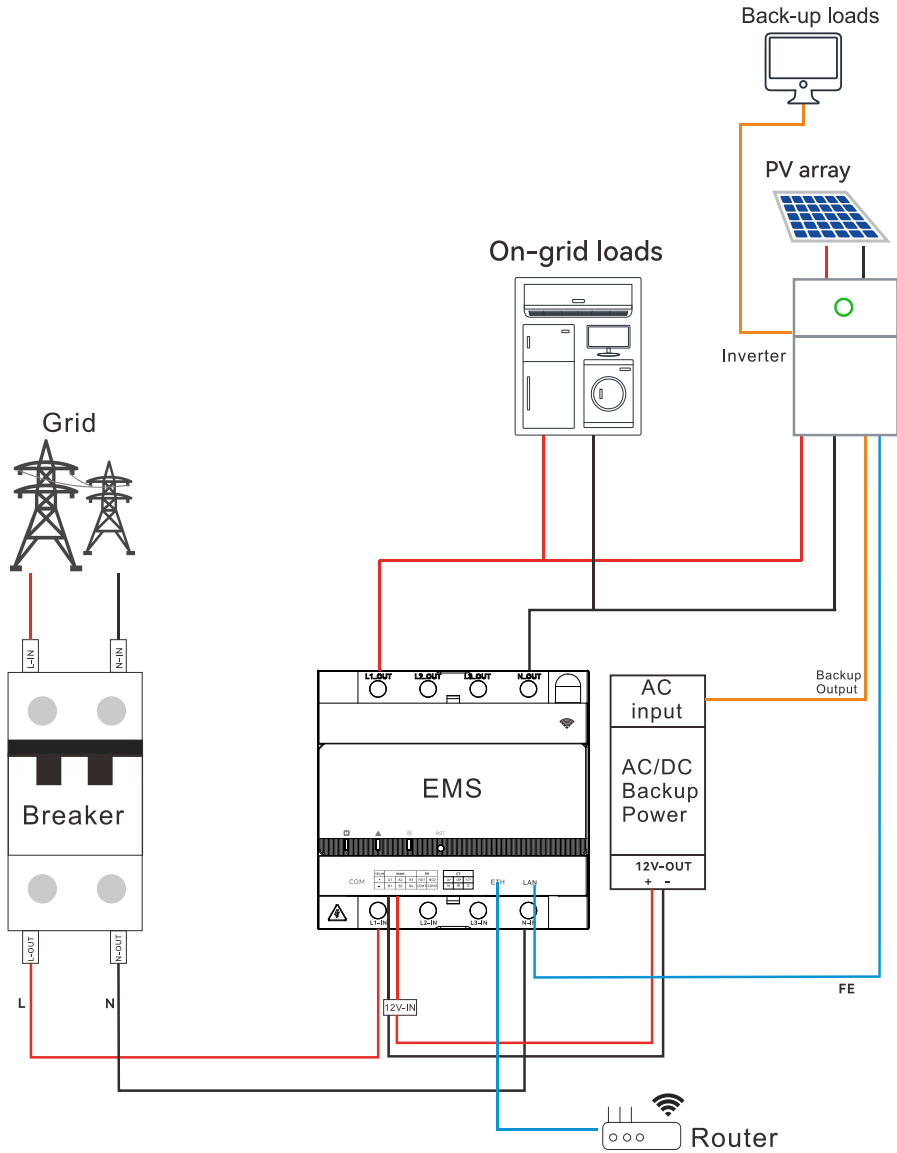

4.1.1.6. Single-phase grid, external CT connection, LAN communication manner

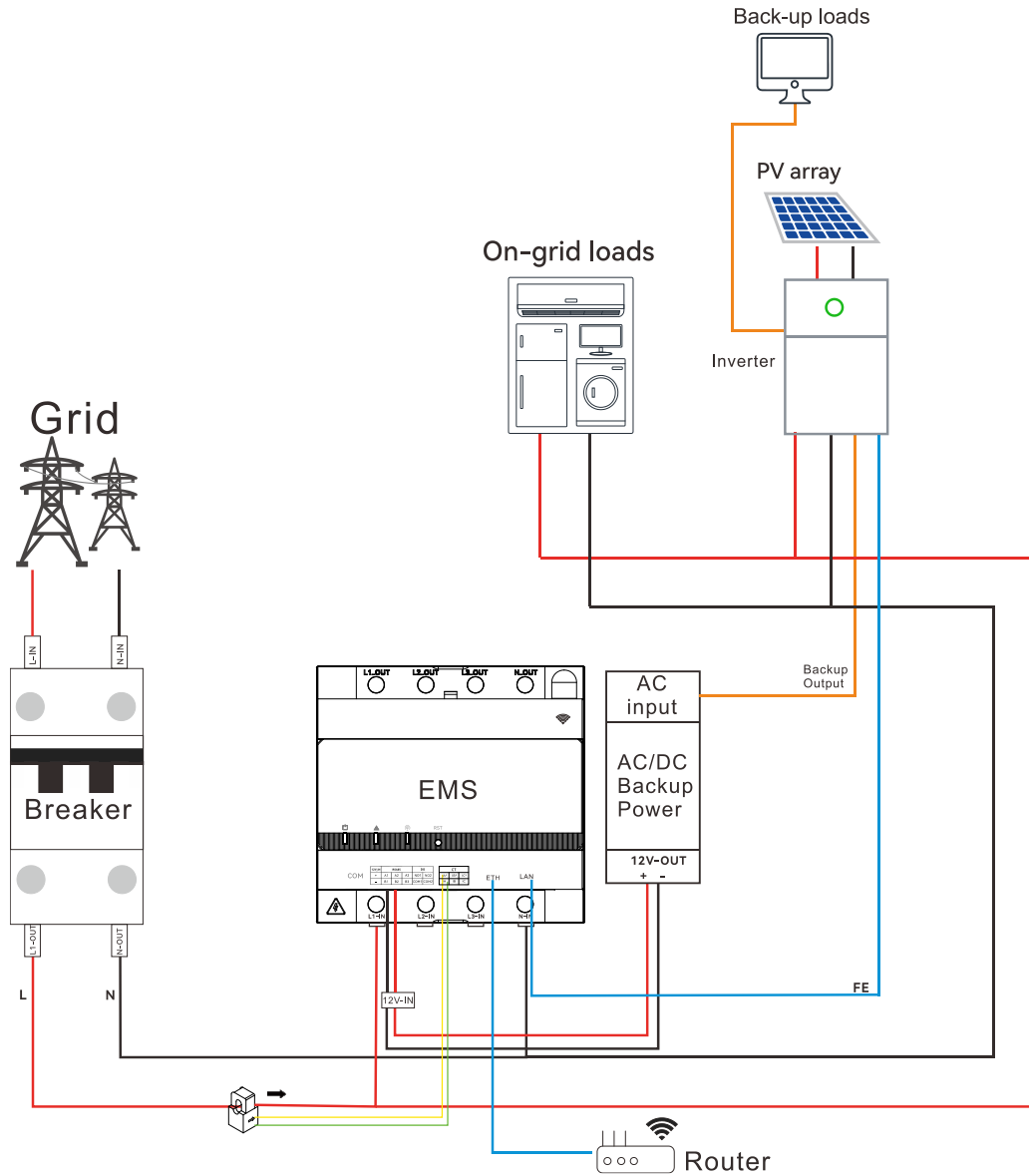

4.1.1.7. Three-phase grid, internal CT connection, LAN communication manner

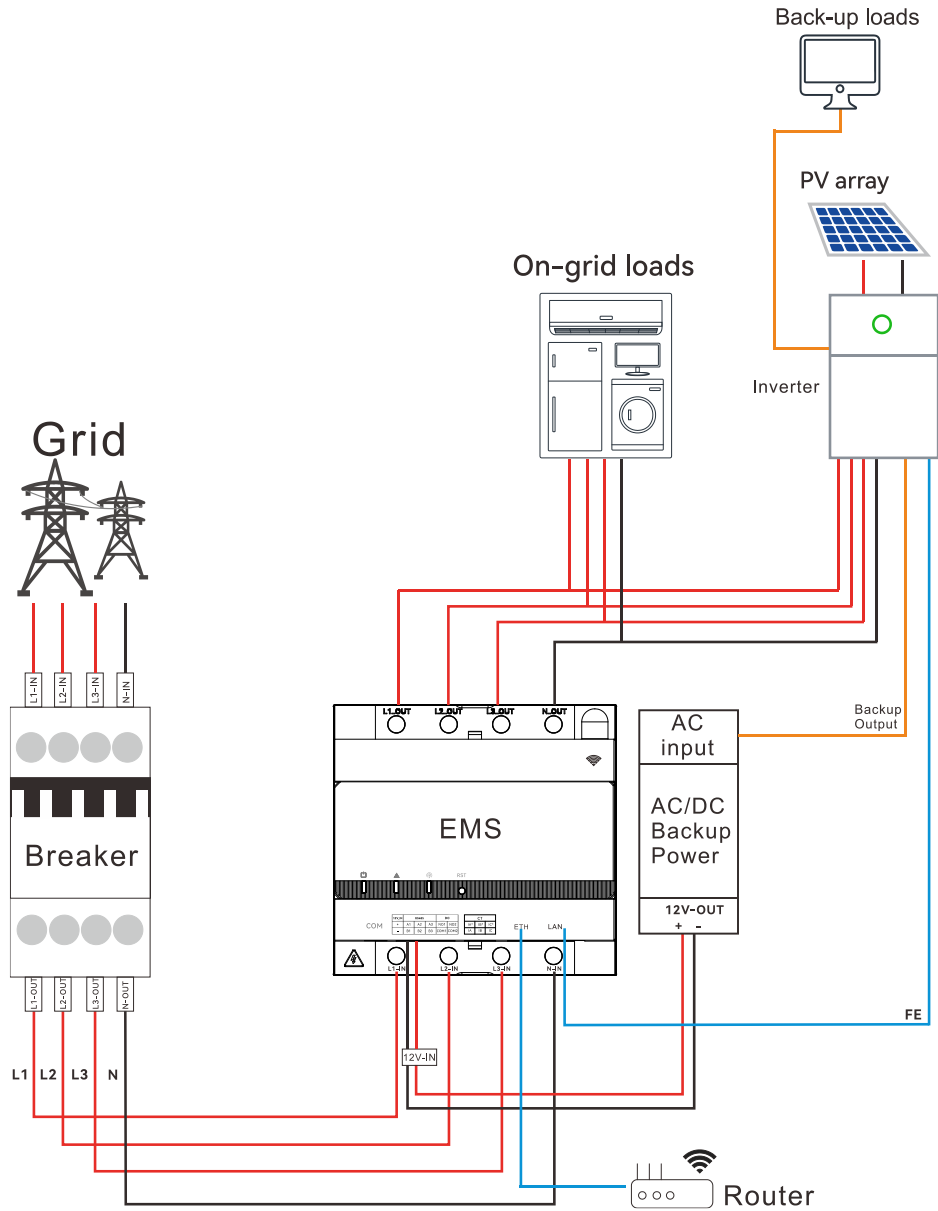

4.1.1.8. Three-phase grid, external CT connection, LAN communication manner

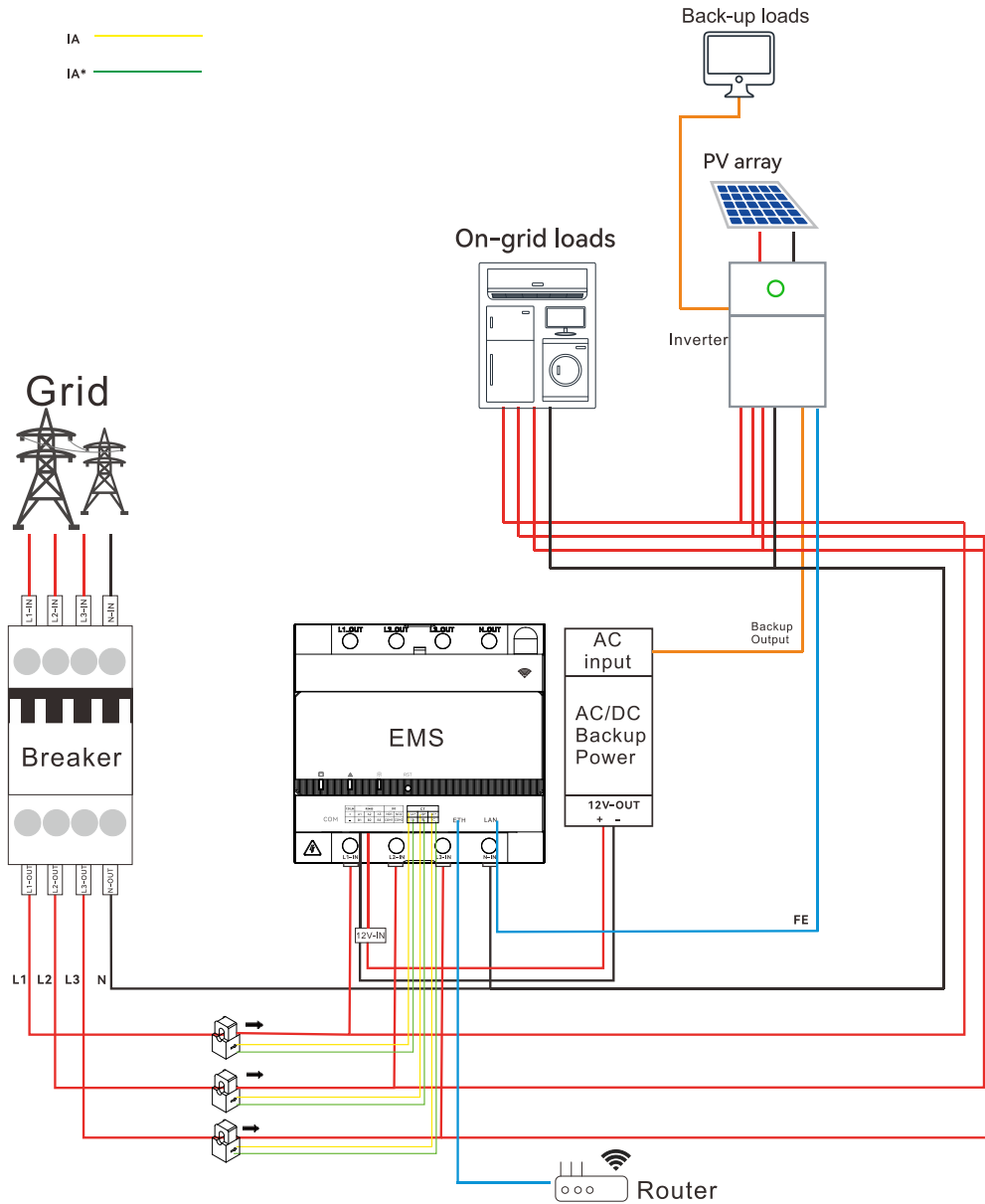



4.1.2. Scenario: inverter quantity ≥ 2 (paralleling connection)

- **RS485 communication connection:**

A maximum of six inverters can be connected paralleled.

Connect the communication cables from the RS485 port on the inverter to the corresponding ports on the eManager, as listed below. If the RS485 port is not available on the inverter, use the EMS/Meter port.

From the RS485 or EMS/Meter port on the inverter	To the RS485 ports on the eManager
Pin 7	RS485-A
Pin 8	RS485-B

Notes:

The eManager provides three pairs of RS485 port combinations. To locate the ports, refer to section 2.6 "Bottom view".

- RS485 A1 and RS485 B1
- RS485 A2 and RS485 B2
- RS485 A3 and RS485 B3

The hybrid inverter is used as an example in the illustrations in this section. In actual conditions, you can connect the solar inverter or hybrid inverter to any pair of the RS485 port combination. However, for one pair of RS485 ports, make sure that:

- The inverters must be of the same type. A hybrid inverter and a solar inverter cannot be connected to the same pair of RS485 port combination.
- A maximum of two inverters are connected.

- **LAN communication connection:**

A maximum of ten inverters can be connected paralleled.

Connect all the communication cables from the LAN port on the eManager and the LAN port on the inverter to a switch.

4.1.2.1. Single-phase grid, internal CT connection (current ≤ 63 A), RS485 communication connection

If the current exceeds 63 A, use the external CT connection manner.

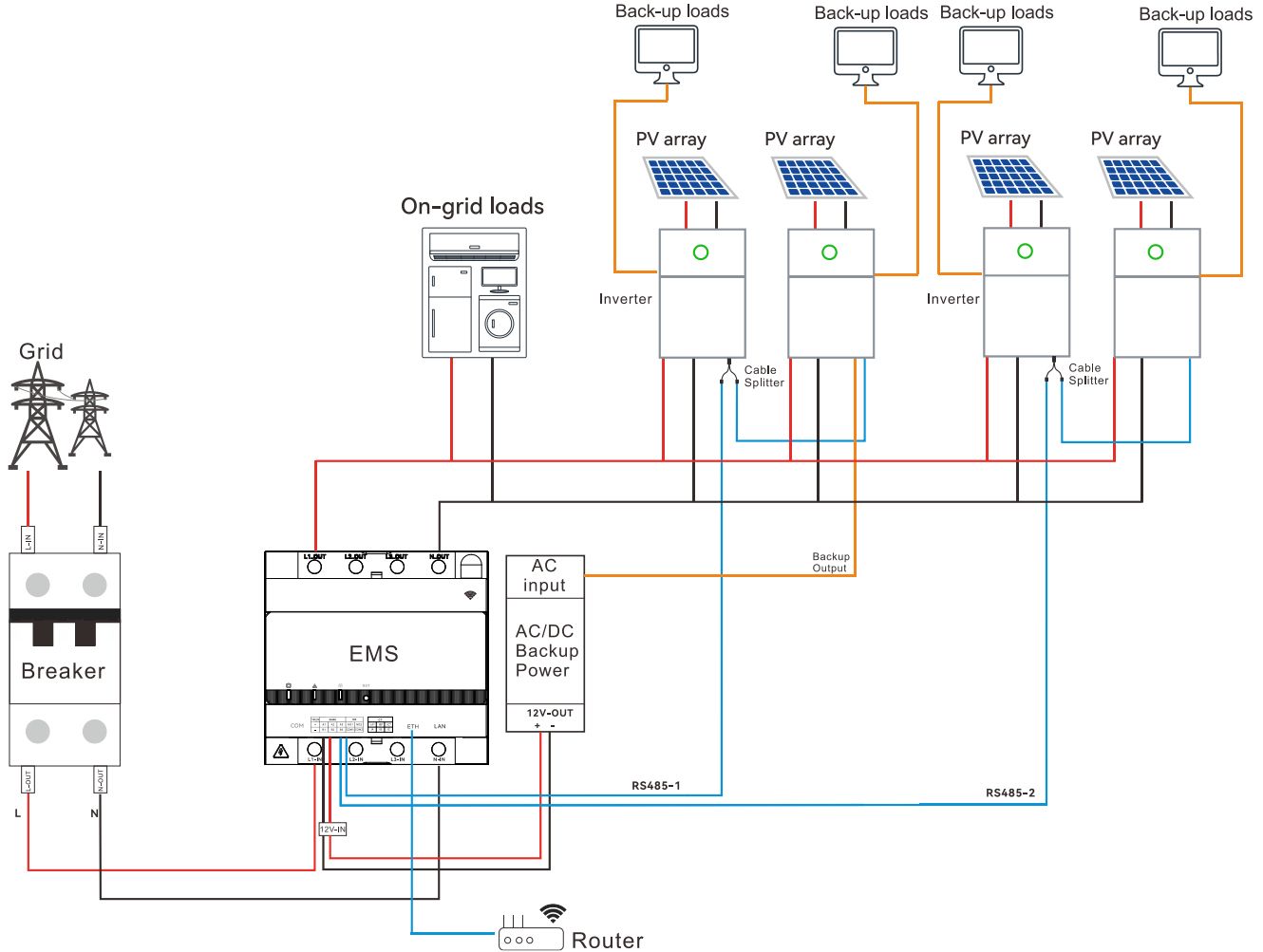

Note: For detailed connection of the AC-DC power supply module, refer to section 4.1 "Connect devices to the EMS".

4.1.2.2. Single-phase grid, external CT connection (current > 63 A), RS485 communication connection

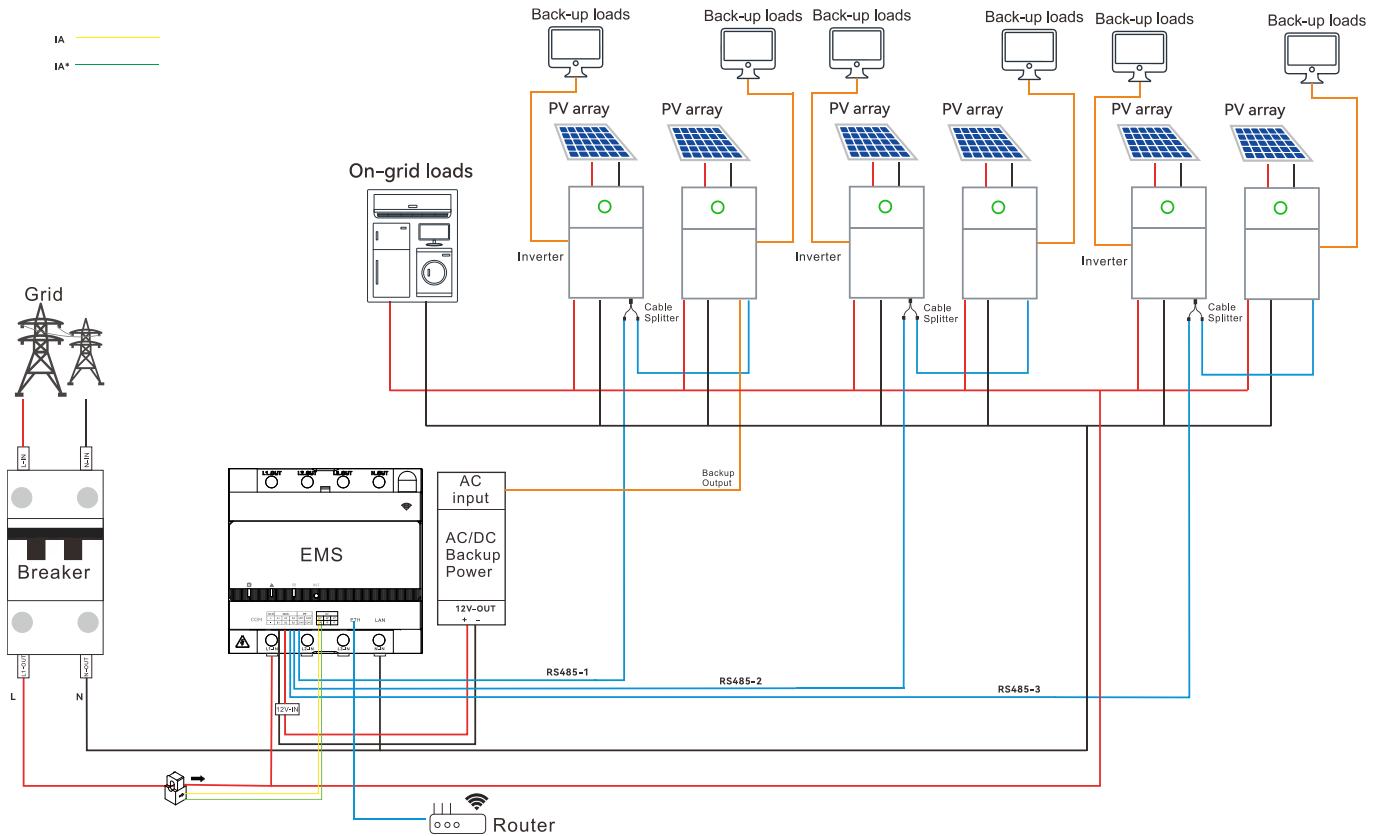

Notes:

- The arrow → on the CT points to the inverter or on-grid loads. In the single-phase grid, the CT wires must be connected to IA* and IA.
- Depending on the plant capacity (the greater value of the total inverter power or the total on-grid load power), use 50xN/A /50 mA CT, wherein N is equal to or greater than 2.
- For detailed connection of the AC-DC power supply module, refer to section 4.1 "Connect devices to the EMS".

4.1.2.3. Three-phase grid, internal CT connection (current ≤ 63 A), RS485 communication connection

If the current exceeds 63 A, use the external CT connection manner.

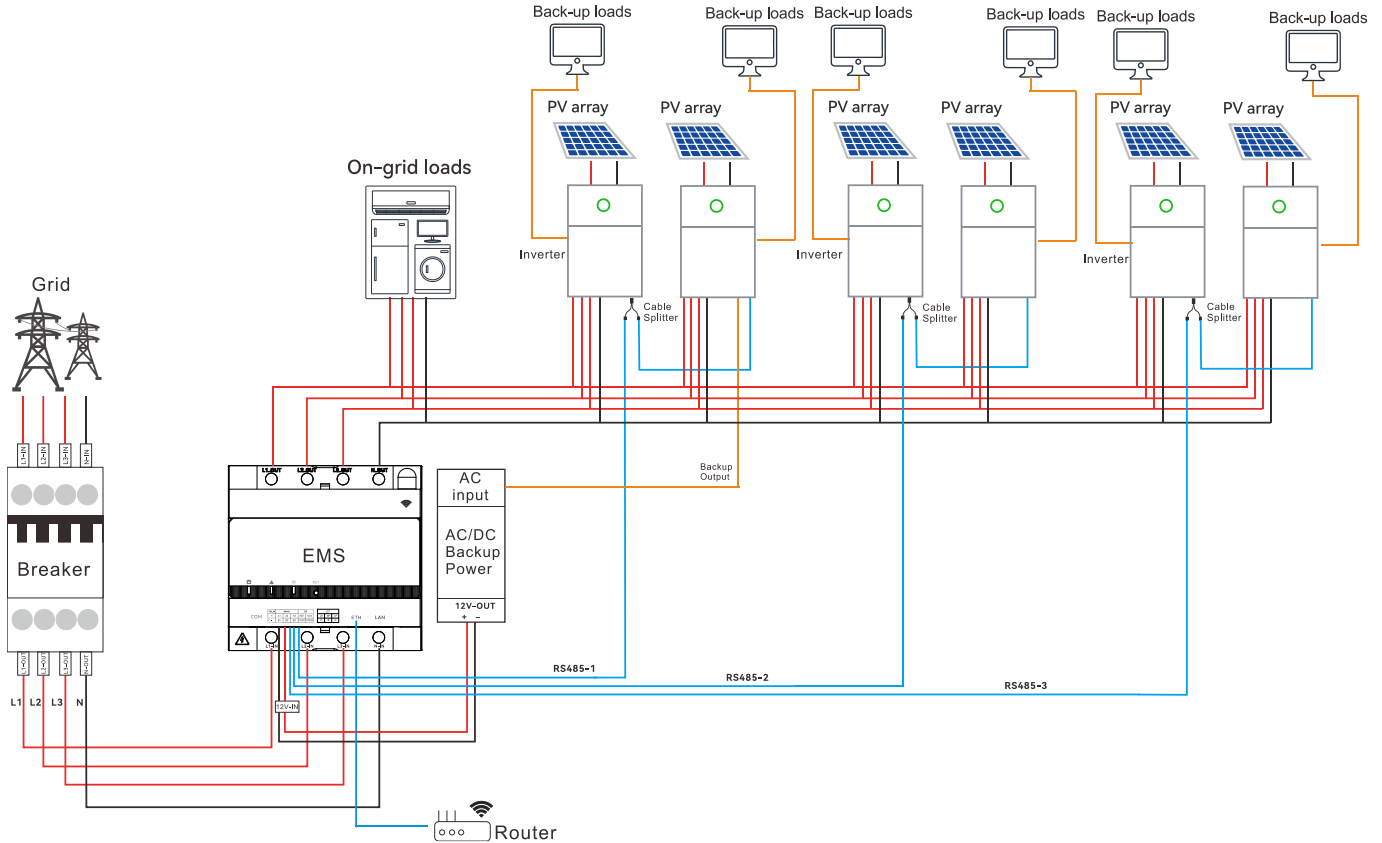

Note: For detailed connection of the AC-DC power supply module, refer to section 4.1 "Connect devices to the EMS".

4.1.2.4. Three-phase grid, external CT connection (current > 63 A), RS485 communication connection

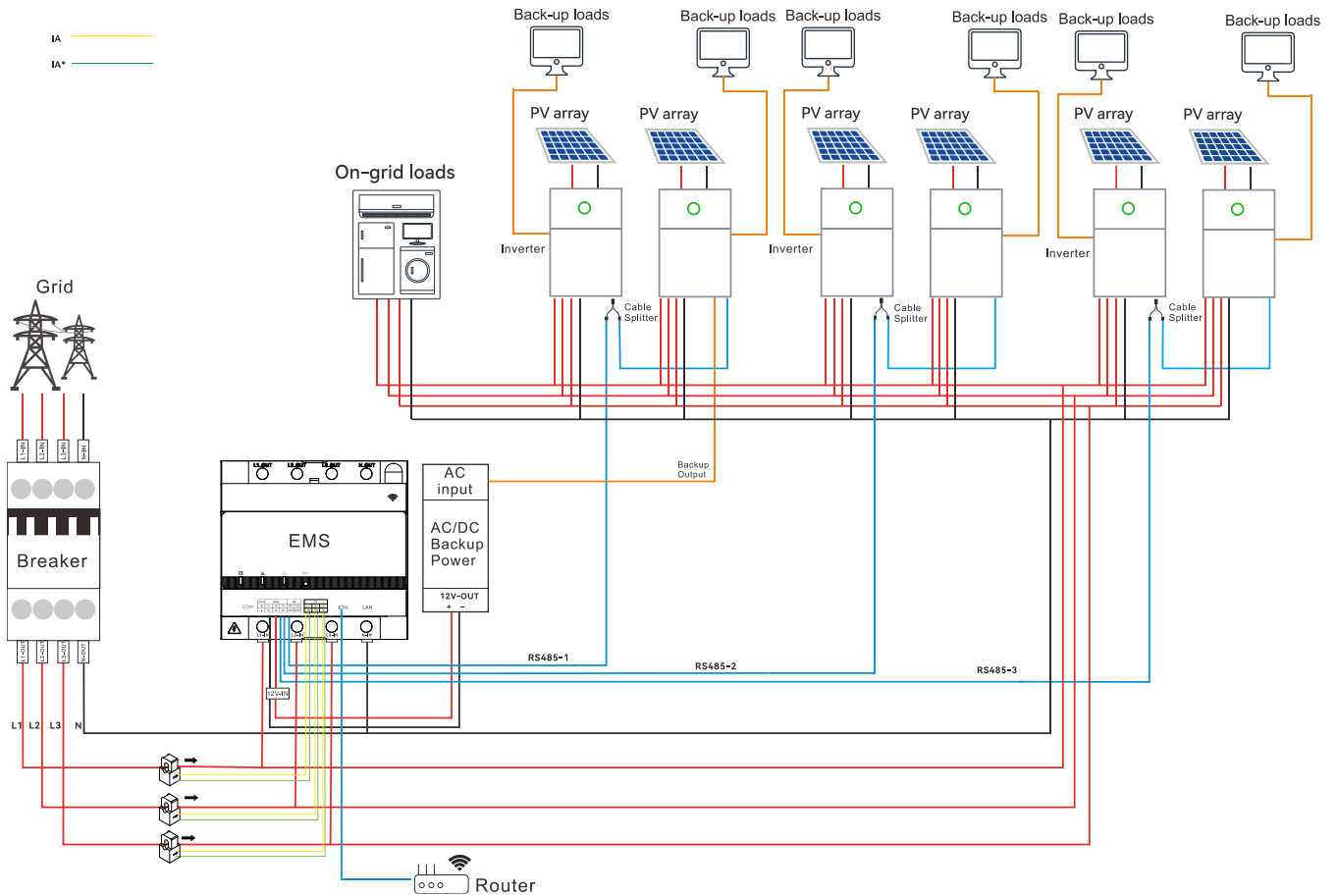

Notes:

- The arrow → on the CT points to the inverter or on-grid loads. In the three-phase grid, the CT wires for the L1, L2, and L3 lines must be connected to the three pairs of CT ports in order: IA* and IA, IB* and IB, IC* and IC.
- Depending on the plant capacity (the greater value of the total inverter power or the total on-grid load power), use 50xVA/50 mA CT, wherein *N* is equal to or greater than 2.
- For detailed connection of the AC-DC power supply module, refer to section 4.1 "Connect devices to the EMS".

4.1.2.5. Single-phase grid, internal CT connection (current ≤ 63 A), LAN communication connection

If the current exceeds 63 A, use the external CT connection manner.

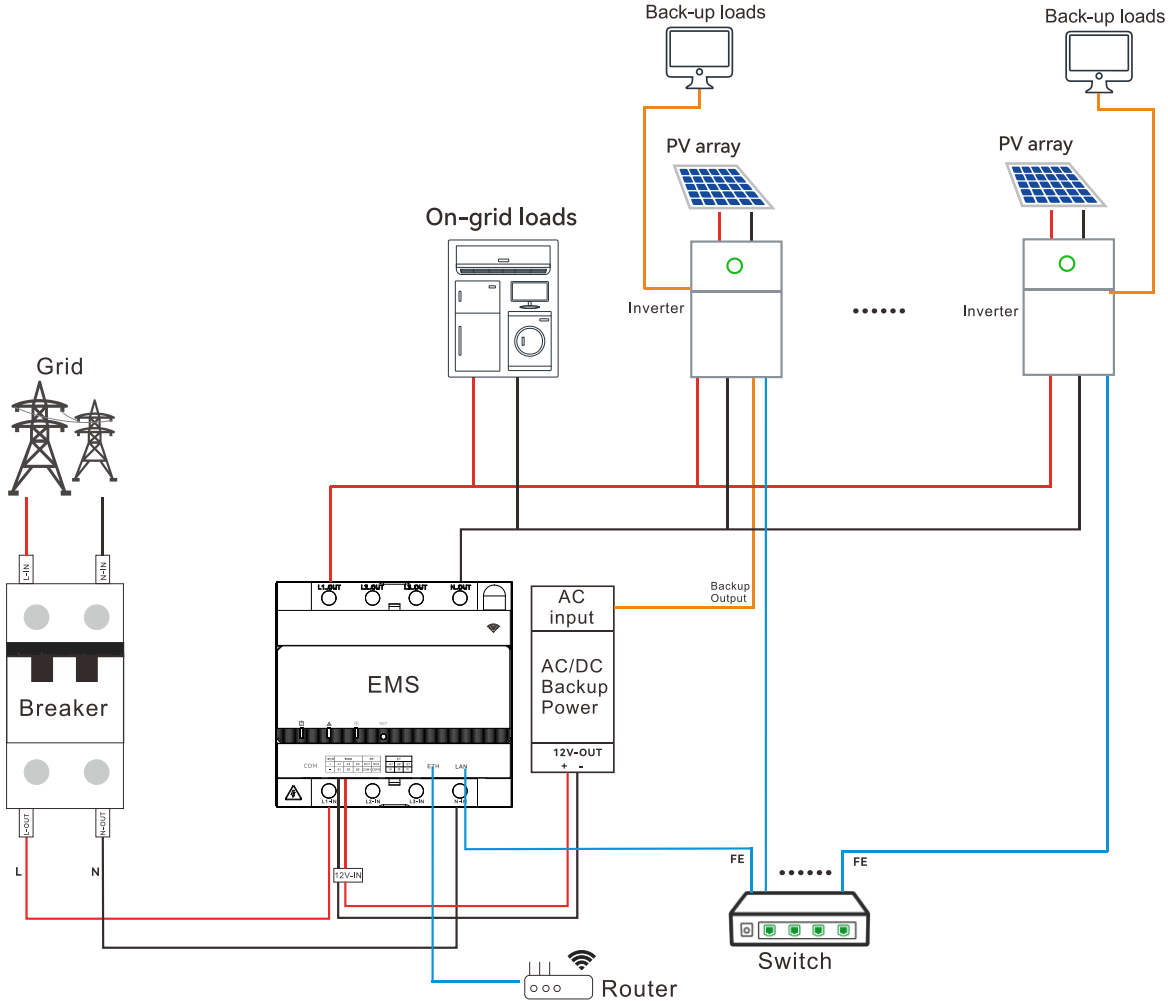

Note: For detailed connection of the AC-DC power supply module, refer to section 4.1 "Connect devices to the EMS".

4.1.2.6. Single-phase grid, external CT connection (current > 63 A), LAN communication connection

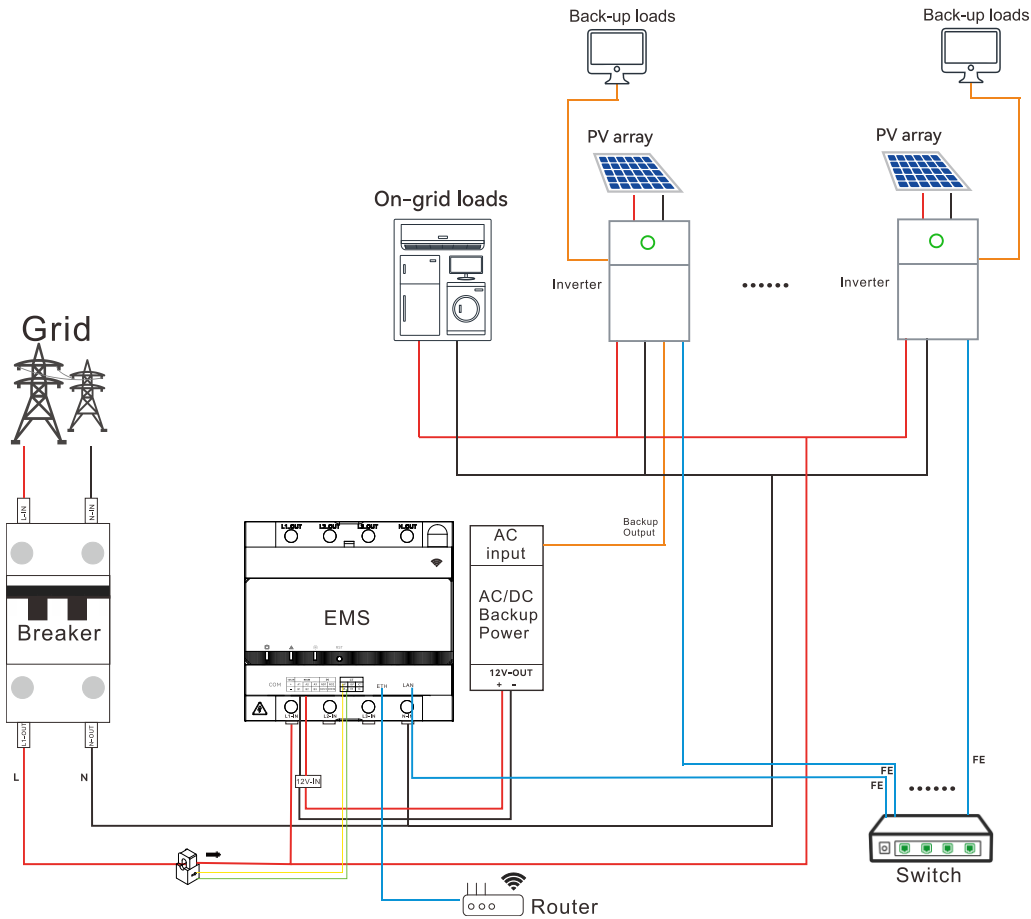

Notes:

- The arrow → on the CT points to the inverter or on-grid loads. In the single-phase grid, the CT wires must be connected to IA* and IA.
- Depending on the plant capacity (the greater value of the total inverter power or the total on-grid load power), use $50 \times N/A / 50 \text{ mA}$ CT, wherein N is equal to or greater than 2.
- For detailed connection of the AC-DC power supply module, refer to section 4.1 "Connect devices to the EMS".

4.1.2.7. Three-phase grid, external CT connection (current ≤ 63 A), LAN communication connection

If the current exceeds 63 A, use the external CT connection manner.

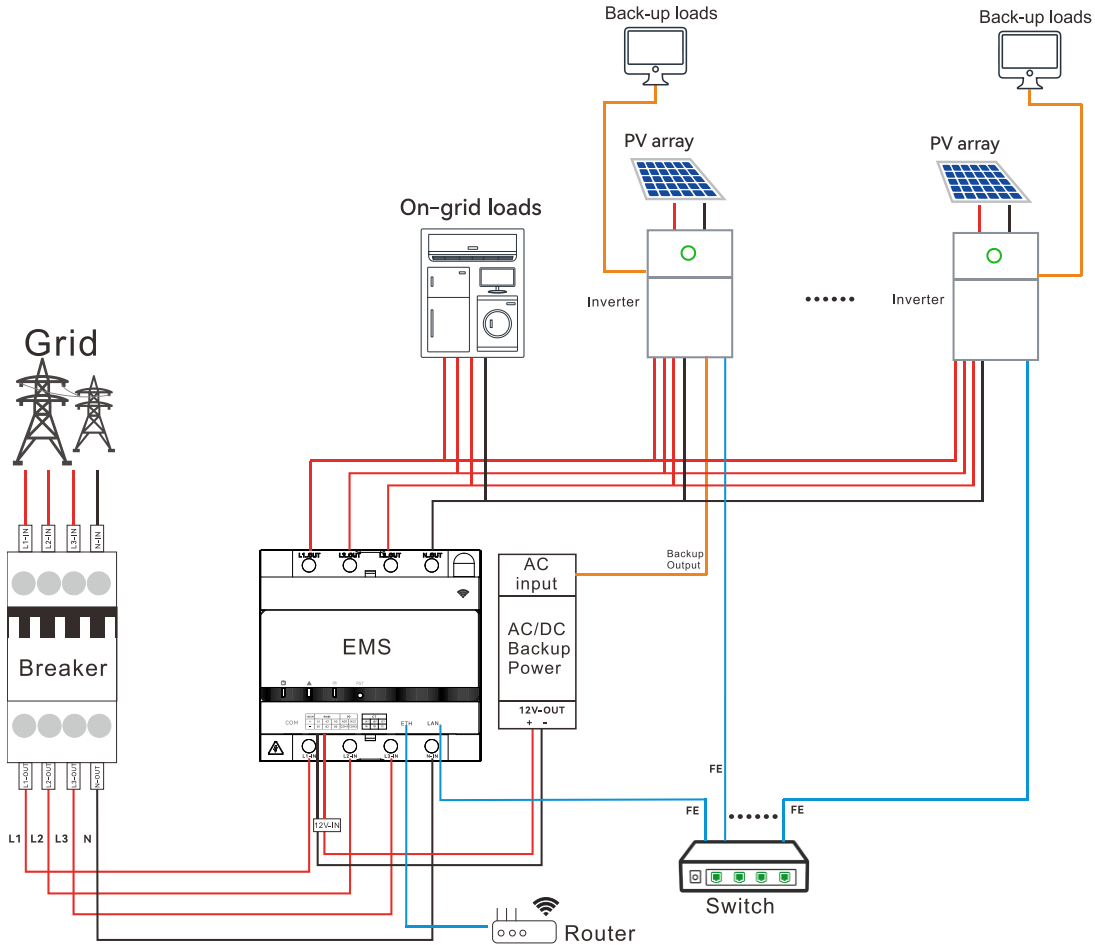

Note: For detailed connection of the AC-DC power supply module, refer to section 4.1 "Connect devices to the EMS".

4.1.2.8. Three-phase grid, external CT connection (current > 63 A), LAN communication connection

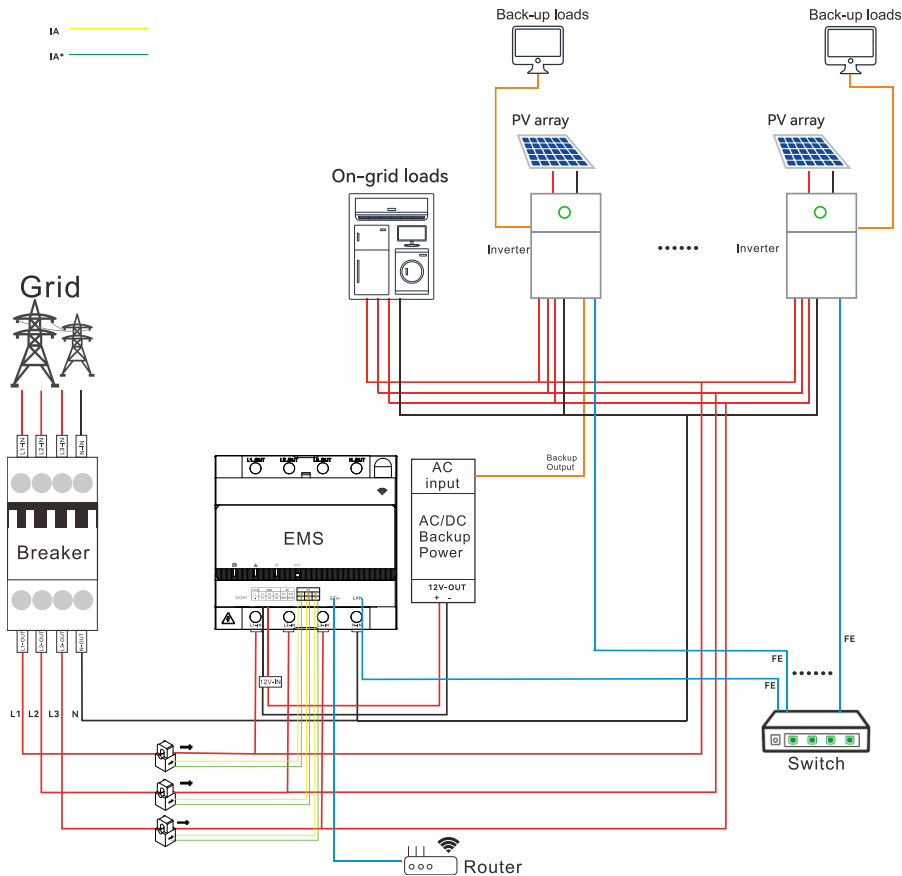

Notes:

- The arrow → on the CT points to the inverter or on-grid loads. In the three-phase grid, the CT wires for the L1, L2, and L3 lines must be connected to the three pairs of CT ports in order: IA* and IA, IB* and IB, IC* and IC.
- Depending on the plant capacity (the greater value of the total inverter power or the total on-grid load power), use $50 \times N/A / 50$ mA CT, wherein N is equal to or greater than 2.
- For detailed connection of the AC-DC power supply module, refer to section 4.1 "Connect devices to the EMS".

4.2. (Optional) Connect the heat pump to the EMS

If a heat pump needs to be used, the eManager provides two pair of DO ports. You can use either pair of the ports.

- NO1 and COM1
- NO2 and COM2

To locate the DO ports, refer to section 2.6 "Bottom view".

4.3. (In Australia and New Zealand) DRM connection

According to the local regulations in Australia and New Zealand, a DRM device is required.

You can connect the DRM device to the following DI terminals (highlighted in green) at the bottom of the Pro-Mate module.

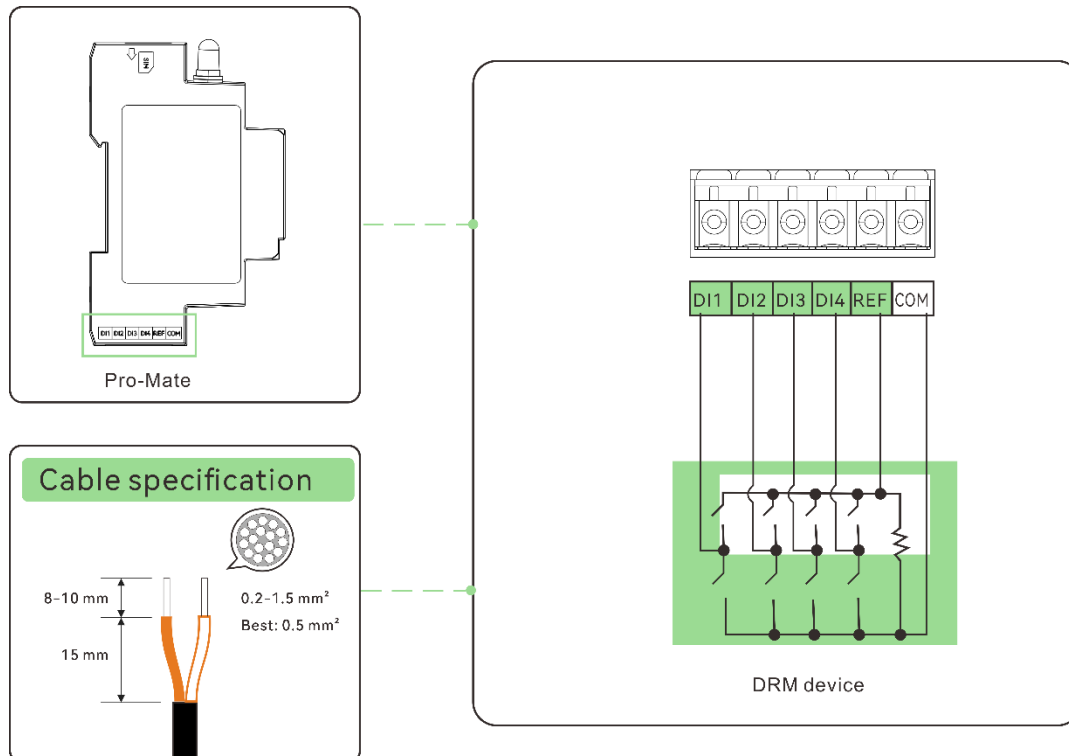

4.4. (In Germany) RCR connection

According to the local regulations in Germany, an RCR device is required.

You can connect the RCR device to the following DI terminals (highlighted in green) at the bottom of the Pro-Mate module.

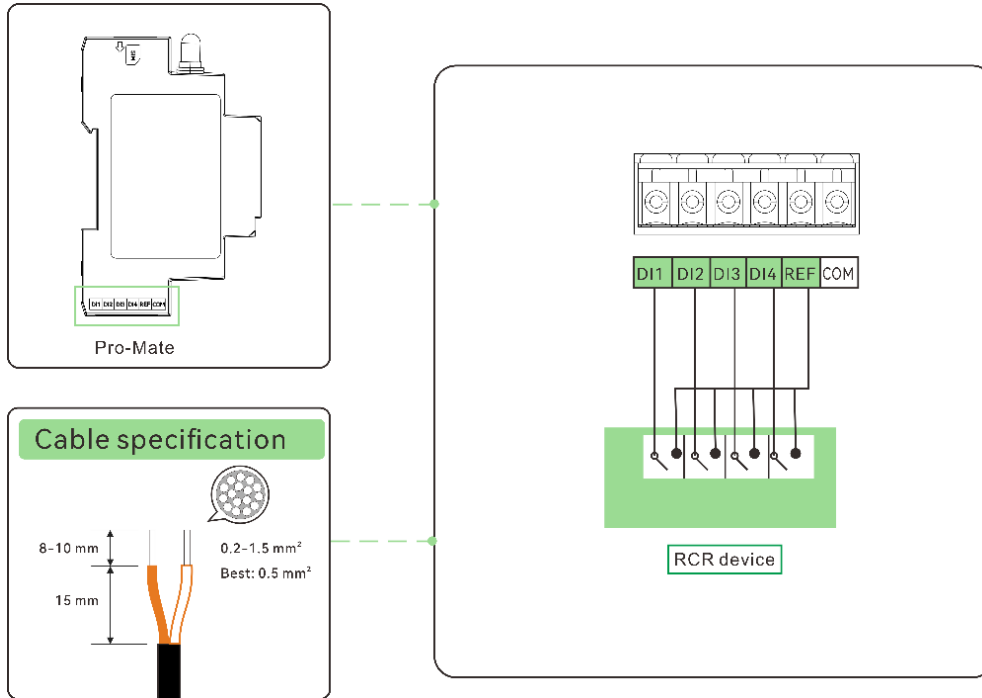



5. Firmware Update (Optional)

This operation is only applicable when the inverter firmware version is not compatible with the EMS firmware version. In this case, you need to upgrade the current inverter firmware version to a compatible one.

1. Check whether your inverter firmware versions (DSP version and ARM version) is earlier than the below listed ones. For detailed operations, refer to section 6.6 "View the inverter firmware version".

Inverter model	DSP version	ARM version
H2-(3K-6K)-S2	V1.030	V6.040
H2-(5K-10K)-T2	V4.066	V1.070
HS2-(5K-10K)-T2	V4.066	V1.070
HS2-(3K-6K)-S2	V1.030	V6.040
R6-(5K-10K)-(S2, S3)	V1.041	V1.069
R6-(5K-15K)-T2	V2.318	V1.069
R6-(15K-50K)-(T2, T3, T4)	V2.580	V6.196
R5-(0.7K-3K)-S1	V1.234	V3.100
R5-(3K-8K)-S2	V1.524	V3.100
H2-(10K-30K)-(T2, T3)	V3.061	V8.035
HS3-(3K-6K)-S2	V1.135	V1.040
HS3-(5K-12K)-T2	V2.103	V2.030

2. If yes, choose one of the following upgrade procedures to upgrade the inverter firmware:

- Remote upgrade (on the Elekeeper Web platform)
- Local upgrade (on the Elekeeper Web platform and the Elekeeper App) (Bluetooth connection)

Note: The operations on the App and Web platform might vary, depending on the versions that you are using.

5.1. Remote upgrade (Web platform)

Step 1. Log in to the Elekeeper Web platform:

- Europe: <https://eop.saj-electric.com>
- China: <https://op.saj-electric.cn>
- Other countries or regions: <https://iop.saj-electric.com/>

Step 2. On the left navigation pane, choose **Service > Firmware Upgrade**. On the right pane, click **Remote upgrade**.

The screenshot displays the 'eSAJ All-in-One Smart EMS' web interface. On the left, the navigation menu includes 'Home', 'Operations Analysis', 'Monitoring', 'Service', and 'Firmware Upgrade'. The 'Service' and 'Firmware Upgrade' items are highlighted with red boxes. The main content area shows a 'Firmware Upgrade' section with 'Remote upgrade' and 'Local upgrade' buttons. Below these are filters for 'Inverter', 'Online Status', and 'Filter', along with 'Reset', 'Upgrade record', and 'Device upgrade' options. A table lists various devices with their SN, status, type, model, software version, and plant name. The table data is as follows:

Device SN	Status	Type	Model	Software Version No.	Plant Name	Online Status	Operation
H3T2103J2400E0000	Offline	Inverter	SH-301-K2T	Control panel(V1.001) Display panel(V0.549)	ESP32模块器件老化测试电站3	Offline	
H3T2103J2400E1713	Offline	Inverter	SH-301-K2T	Control panel(V1.001) Display panel(V0.549)	ESP32模块器件老化测试电站1	Offline	
HSS2603Q2408E12345	Offline	Inverter	HS2-6K-S2	Control panel(V1.020) Display panel(V6.022)	ESP32模块器件老化测试电站1	Offline	
HZT3303Q2341E00002	Inventory machine	Inverter	H2-30K-T3	Control panel(V3.008) Display panel(V6.021)	--	Offline	
CH2503Y1332C95867	Offline	Inverter	CSV-50K-T6	Control panel(V6451) Display panel(V6883)	--	Offline	
CH2503Y1727E40401	Offline	Inverter	CH2-50K-T6	Control panel(V2767) Display panel(V4916)	--	Offline	
RS0205J2342E56617	Offline	Inverter	RS-5K-T2-15	Control panel(V1.063) Display panel(V1.035)	--	Offline	
CMP1Q100G1123E40219	Offline	Inverter	CM1-100K-215	Control panel(V7623) Display panel(V1289)	M5530J2317121255	Offline	
CMP1Q100G2342C09697	Offline	Inverter	CM1-100K-215	Control panel(V9006) Display panel(V369)	M5530J2317121255	Offline	
CMP1Q100G1415E21989	Offline	Inverter	CM1-100K-215	Control panel(V3244) Display panel(V2554)	--	Offline	

At the bottom of the table, it shows 'Total 40539' and a pagination control for page 1 of 10 pages.



Step 3. Select **Inverter** or **Communication module** to display corresponding devices.

Note: No need to upgrade the battery.

The screenshot displays the 'Firmware Upgrade' interface. On the left, a sidebar menu includes options like 'Home', 'Operations Analysis', 'Monitoring', 'Service', 'Plant Transfer', 'Device Transfer', 'End user transfer', 'Firmware Upgrade' (highlighted), 'Warranty Check', 'Warranty Registration', 'Device import and replacement', 'Remote configuration', and 'Curve Analysis'. The main area has a breadcrumb 'Home > Firmware Upgrade' and two tabs: 'Remote upgrade' (active) and 'Local upgrade'. A filter dropdown is set to 'Inverter', with a search bar and 'Filter' and 'Reset' buttons. Below is a table of devices:

	Status	Type
<input type="checkbox"/> HS3T2103J2400E1713	Offline	Inverter
<input type="checkbox"/> HSS2603G2408E12345	Offline	Inverter
<input type="checkbox"/> H2T3303G2341E00082	Inventory machine	Inverter
<input type="checkbox"/> CH2503Y1332C95867	Offline	Inverter
<input type="checkbox"/> CH2503Y1727E40401	Offline	Inverter
<input type="checkbox"/> R5I2053J2342E56617	Offline	Inverter

Alternatively, you can locate the required device based on its SN: Click **Filter** to display the detailed search box. Input the SN and click **OK**.

The screenshot shows the 'Firmware Upgrade' section of the eSAJ All-in-One Smart EMS interface. The left sidebar contains navigation options such as Home, Operations Analysis, Monitoring, Service, and various transfer and configuration options. The main area is divided into 'Remote upgrade' and 'Local upgrade' tabs. Under 'Local upgrade', there are filters for 'Inverter' and 'Online Status'. A search bar with a magnifying glass icon and a 'Filter' button is present. Below the filters, there are input fields for 'Plant country', 'Module SN', 'Inverter SN', and 'Battery SN'. The 'Inverter SN' field is highlighted with a red box and contains the value 'HSS2502Y2231E00111'. To the right of these fields are input fields for 'Device owner', 'Model', 'Display panel', 'Control panel', 'Slave control board', and 'BMS Built-in panel', each with a 'Version range' dropdown and a 'Software Version N' or 'Hardware Version N' input. At the bottom right, there are 'Clear', 'Cancel', and 'OK' buttons. The 'OK' button is highlighted with a red box. On the far right, there is a 'Software Version No.' table with multiple rows of version information. At the bottom right, there is a pagination control showing '4964 > Go to 1 10/page'.

Note: For batch upgrade, separate the device SNs by using the comma (,).

Step 4. Select the required device and click **Device upgrade**.

Device SN	Status	Type	Model	Software Version No.	Plant Name	Online Status	Operation
<input checked="" type="checkbox"/> HSS2502Y2231E00111	Alarm	Inverter	HS2-5K-S2	Control panel(V9.053) Display panel(V7.059)	SEP000PE06	Online	Device upgrade

Step 5. Select the firmware version: To upgrade to the up-to-date firmware version, select the latest firmware version; to upgrade to a specific firmware version, click **Upload local upgrade package** to upload the local upgrade file.

Set the upgrade time: Depending on your needs, upgrade the firmware right now or in a specific time:

- Upgrade now: Select **Instant distribution** and click **Upgrade Now**.
- Upgrade later: Select **Regular distribution**, set the specific upgrade time, and click **Upgrade Now**. The upgrade will start according to the configured time.

Device upgrade

Display Board [ST]

No upgrade Upload local upgrade package

Control board

v5.059 New No upgrade Upload local upgrade package

Upgrade time

Instant distribution Regular distribution 00:00:00 To 23:59:59

Duration of the task

1day 30day 90day 180day

Cancel Upgrade Now



Step 6. Click **Upgrade record** and then click the  icon under **Operation** to view the upgrade details (including the upgrade status and result).

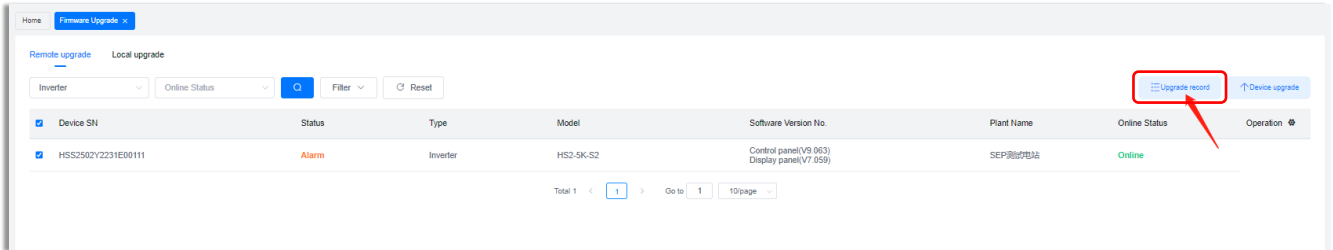

Home Firmware Upgrade

Remote upgrade Local upgrade

Inverter Online Status Filter Reset





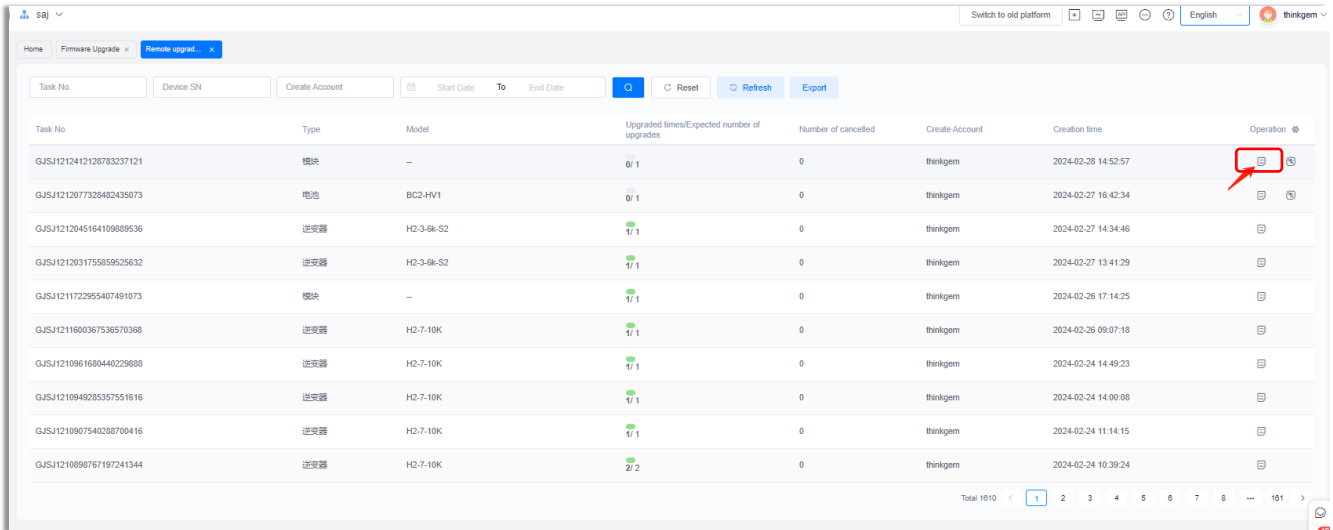





Device SN	Status	Type	Model	Software Version No.	Plant Name	Online Status	Operation
HSS2502Y2231E00111	Alarm	Inverter	HSS-5K-S2	Control panel(V9.063) Display panel(V7.059)	SEP测试电站	Online	

Total 1 < 1 > Go to 1 10/page



Home Firmware Upgrade Remote upgrad

Task No. Device SN Create Account Start Date To End Date Q Reset Refresh Export

Task No.	Type	Model	Upgraded times/Expected number of upgrades	Number of cancelled	Create Account	Creation time	Operation
GJSJ1212412128783237121	模块	--	0/1	0	thinkgem	2024-02-28 14:52:57	
GJSJ1212077328482435073	电池	BC2-HV1	0/1	0	thinkgem	2024-02-27 16:42:34	
GJSJ1212045164109809536	逆变器	H2-3-9k-S2	1/1	0	thinkgem	2024-02-27 14:34:46	
GJSJ1212031755859525632	逆变器	H2-3-9k-S2	1/1	0	thinkgem	2024-02-27 13:41:29	
GJSJ1211722965407491073	模块	--	1/1	0	thinkgem	2024-02-26 17:14:25	
GJSJ1211600367536570368	逆变器	H2-7-10K	1/1	0	thinkgem	2024-02-26 09:07:18	
GJSJ1210961680440229888	逆变器	H2-7-10K	1/1	0	thinkgem	2024-02-24 14:49:23	
GJSJ1210948285357551616	逆变器	H2-7-10K	1/1	0	thinkgem	2024-02-24 14:00:08	
GJSJ1210907540238700416	逆变器	H2-7-10K	1/1	0	thinkgem	2024-02-24 11:14:15	
GJSJ1210896767197241344	逆变器	H2-7-10K	2/2	0	thinkgem	2024-02-24 10:39:24	

Total 1010 < 1 2 3 4 5 6 7 8 ... 101 >



Upgrade status: Being upgraded.

Note: Here takes the communication module as an example.

Task No. GJSJ1212412128783237121
Type 模块
Model

Upgrade method Remote upgrade
Upgraded times 0
Expected number of upgrades 1

Create Account thinkgem
Creation time 2024-02-28 14:52:57
Distribution time Instant distribution

Upgrade details

Upgrade SN Start Date End Date Select Search Reset Refresh Export

Upgrade SN	Upgrade account	Battery SN	Upgrade status	Firmware to be upgraded	Original firmware	Distribution start time/Distribution end time	Upgrade start time/Upgrade end time	Operation
M5560J2325000001	thinkgem		正在升级 (restart app)	通讯模块(1.001)	通讯模块(V1.002.2)	2024-02-28 15:14:59 2024-02-28 15:15:00	2024-02-28 15:15:00	

Total 1 < 1 >

Upgrade status: Upgrade successfully.

Note: Here takes the communication module as an example.

Task No. GJSJ1211722955407491073
Type 模块
Model

Upgrade method Remote upgrade
Upgraded times 1
Expected number of upgrades 1

Create Account thinkgem
Creation time 2024-02-26 17:14:25
Distribution time Instant distribution

Upgrade details

Upgrade SN Start Date End Date Select Search Reset Refresh Export

Upgrade SN	Upgrade account	Battery SN	Upgrade status	Firmware to be upgraded	Original firmware	Distribution start time/Distribution end time	Upgrade start time/Upgrade end time	Operation
M5560J2325000001	thinkgem		升级成功 (success)	通讯模块(1.002.2)	通讯模块(V1.002.1)	2024-02-26 17:14:45 2024-02-26 17:14:48	2024-02-26 17:14:48 2024-02-26 17:15:15	

Total 1 < 1 >

5.2. Local Upgrade (Web page and App) (Bluetooth connection)

Before you start

The firmware package has been uploaded. If any question, contact SAJ technical support.

Procedure

Step 1. Log in to the Elekeeper Web platform:

- Europe: <https://eop.saj-electric.com>
 - China: <https://op.saj-electric.cn>
 - Other countries or regions: <https://iop.saj-electric.com/>
- a. On the left navigation pane, click the  icon and choose **Local upgrade > Firmware upgrade tasks**.
 - b. On the **Please select upgrade** section, select the device type, model name, and required firmware version.
 - c. On the **Upgradable equipment** section, input the device SN.
 - d. Click **OK**.

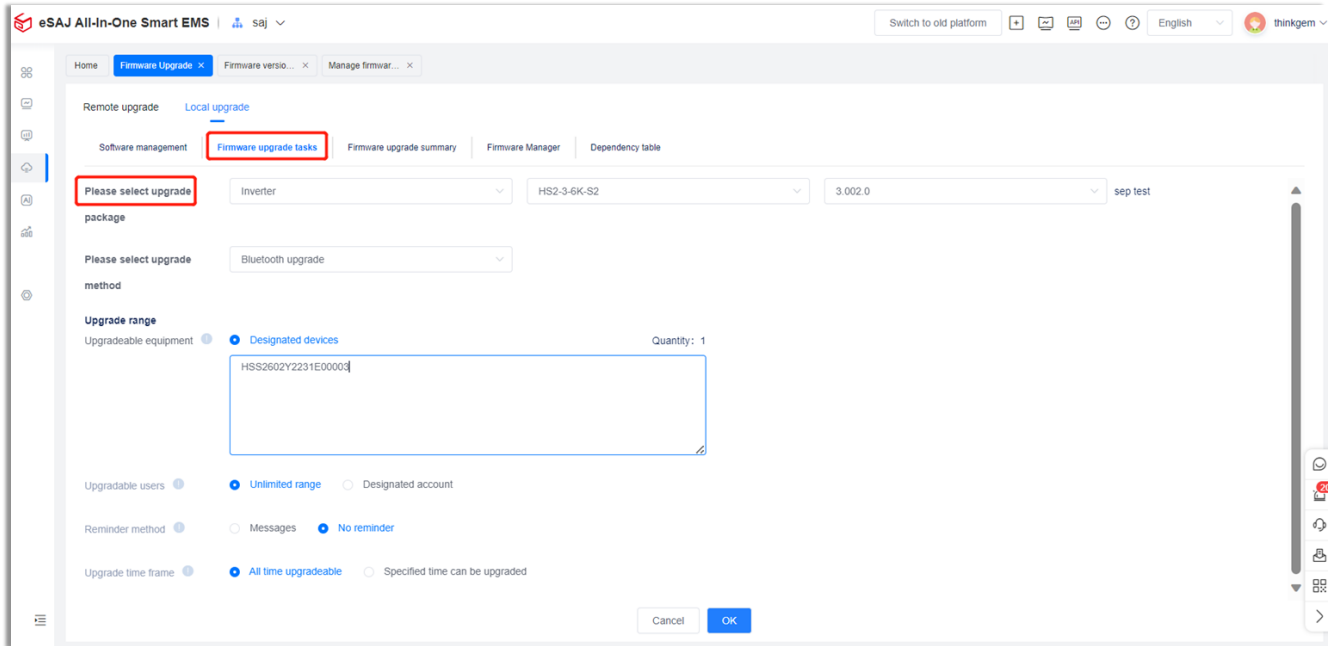

eSAJ All-In-One Smart EMS | saj

Switch to old platform

Home | Firmware Upgrade | Firmware version... | Manage firmwar... | English | thinkgem

Remote upgrade | Local upgrade

Software management | **Firmware upgrade tasks** | Firmware upgrade summary | Firmware Manager | Dependency table

Please select upgrade package

Inverter | HS2-3-6K-S2 | 3.002.0 | sep test

Please select upgrade method

Bluetooth upgrade

Upgrade range

Upgradeable equipment | Designated devices | Quantity: 1

HSS2602Y2231E0000d

Upgradable users

Unlimited range | Designated account

Reminder method

Messages | No reminder

Upgrade time frame

All time upgradeable | Specified time can be upgraded

Cancel | OK



Step 2. Log in to the Elekeeper App. Select the required EMS device (eManager:xxxxx, wherein xxxxx indicate last five digits of the EMS device SN). Tap **Firmware Update** and then tap the device to be upgraded.

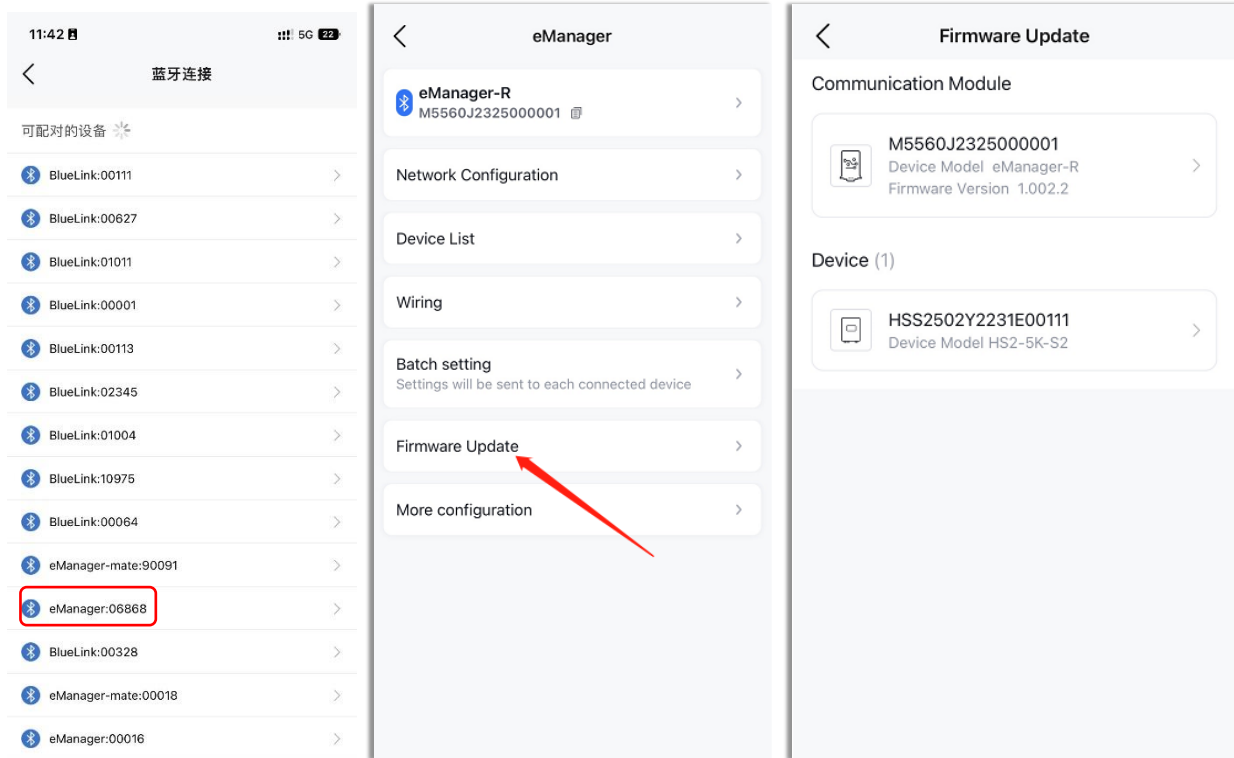

Step 3. On **Firmware Update**, select the latest version and tap **Update**. On the displayed dialog box, tap **OK** to confirm the upgrade.

During the upgrade, the Bluetooth connection will be disconnected.

After the upgrade, reconnect the Bluetooth and tap **Firmware Update** again to check the upgrade result.

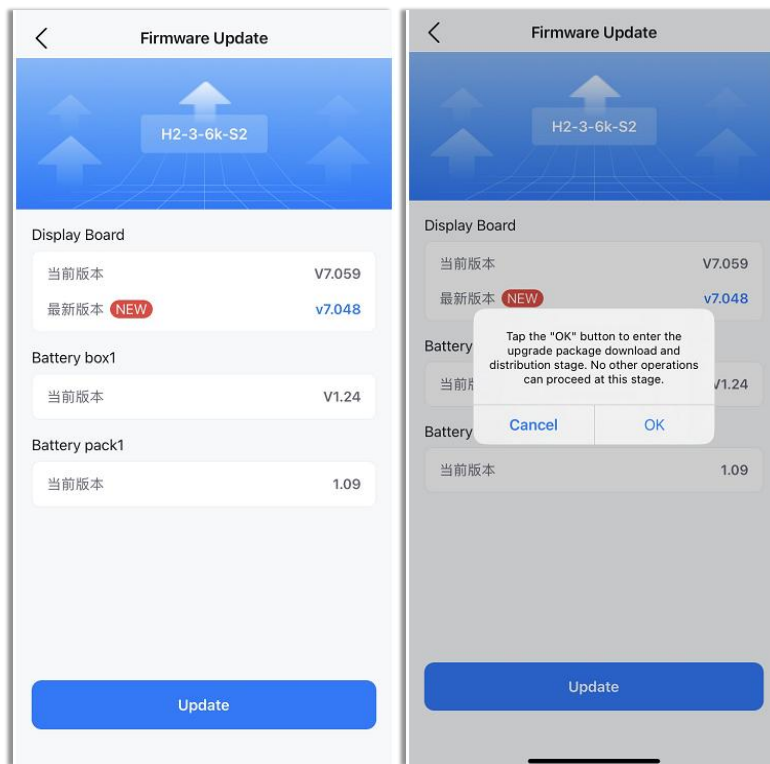



5.3. Operations After the upgrade

Step 1. Use the AIO3 module installed on the inverter to make sure that all the following conditions are met:

- a. the inverter is set to no meter status;
- b. the parallelling mode is disabled; and
- c. the export limit function is disabled.

Step 2. If the AIO3 module is installed on the inverter, remove it from the inverter. If the AIO3 module is embedded in the inverter, set it to Ethernet connection mode and then disconnect the Ethernet cable from the LAN port on the inverter.

6. Commissioning by the App

The Elekeeper App can be used for both nearby and remote monitoring. It communicates with different devices through Bluetooth or Ethernet connection.

The detailed operations on the App might vary, depending on the version you are using.

6.1. Install the App

On your mobile phone, search for “Elekeeper” in the App store. Download and install the App.

6.2. Log in to the App

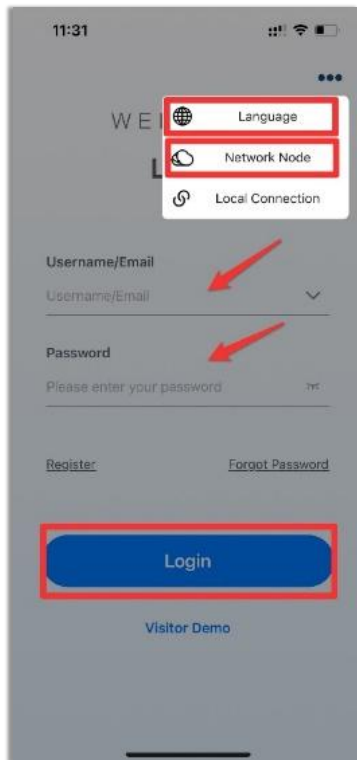

Have an account? — Log in to the App.

1. Tap the three-dot icon **☰** on the top right corner. Choose the language and network node based on your needs.
2. Use your account and password for login.

No account? — Apply for a new account for login.

1. Tap the three-dot icon  on the top right corner. Choose the language and network node based on your needs.
2. Tap **Register**. Choose whether you are an owner, an installer, or a distributor.

Note: For commissioning convenience, it is suggested that the install apply for the owner account.

3. Set your username, country/region, time zone, email, and password. Select the registration agreements and confirm the registration.

Use the applied account and the password for login

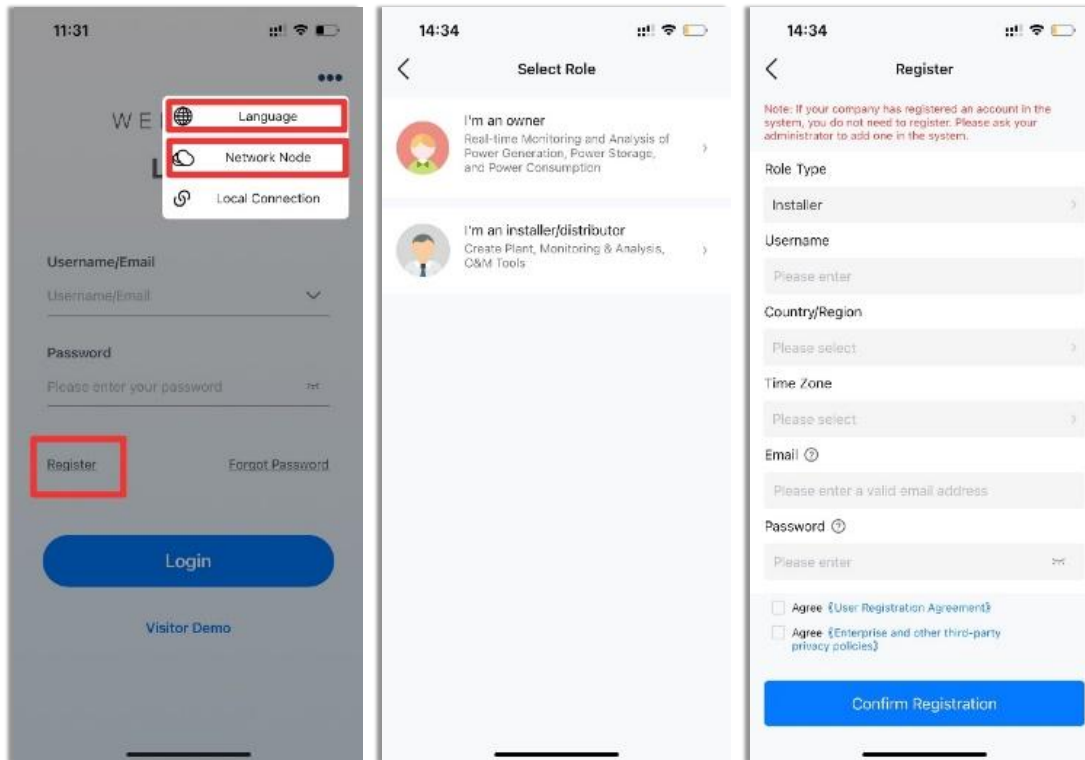

6.3. Perform the initialization settings

Before you start

Enable the Bluetooth function on your mobile phone.

Procedure

1. On the **Home** or **Service** page, tap **Remote Configuration**. Tap **Bluetooth** and then **Next**.

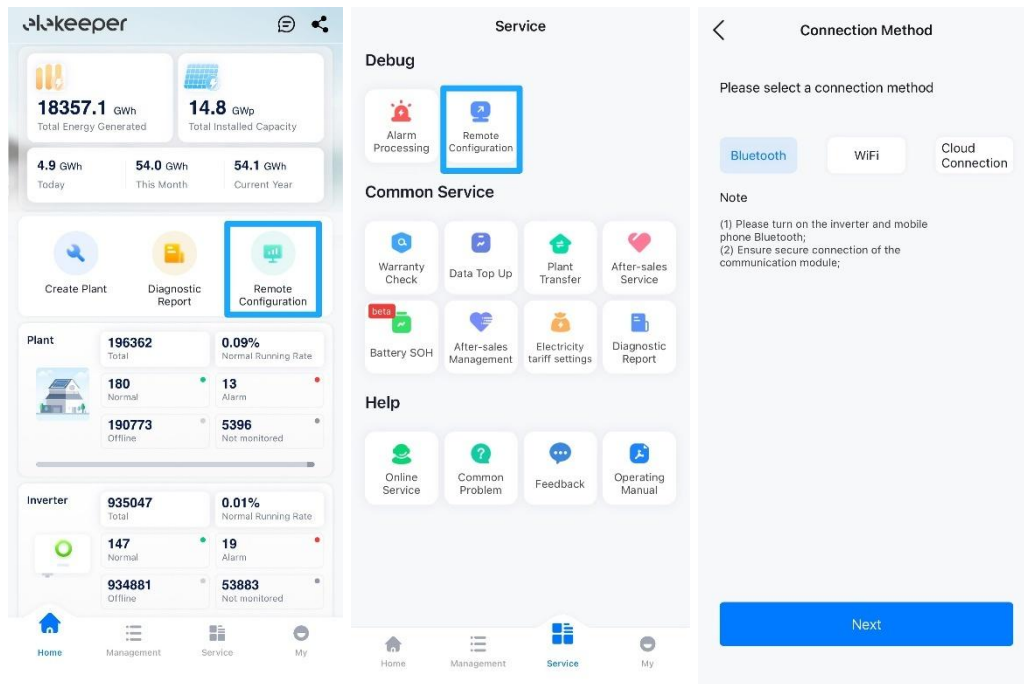



2. Choose your EMS device (eManager:xxxxx) from the device list. Then, tap **Initialization**.

Note: xxxxx are the last five digits of the serial number (SN) of your EMS device.

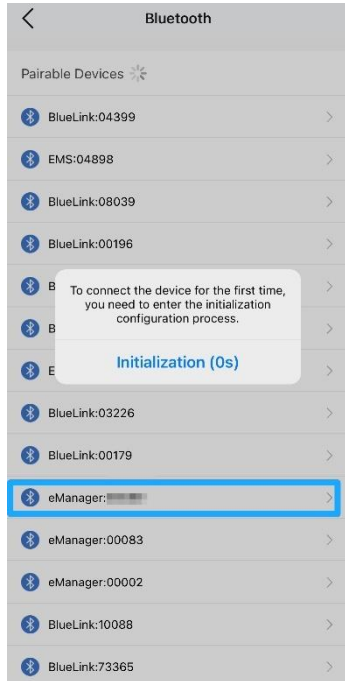

3. Network configuration

Select **Ethernet** or **WiFi** according to your needs. Set the related parameters.

Note: To use **Ethernet**, make sure that the Ethernet cable is connected from the ETH port on the eManager to the LAN port on the router.

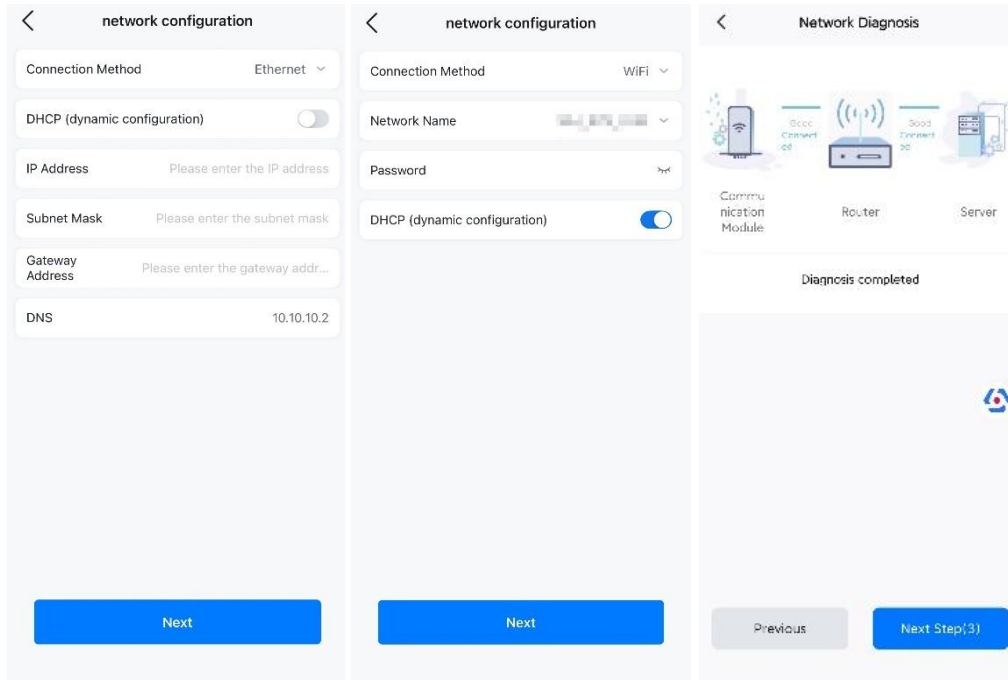

4. Device configuration

Depending on your inverter model, use one of the following connection manners.

- RS485 parallelling connection

To add an inverter, locate its RS485 connection (**RS485_1**, **RS485_2**, or **RS485_3**), tap **Add device**, and scan the SN barcode or input the SN manually.

Notes:

- Make sure that all inverters are added in the corresponding RS485 connection setting area. For example, when two inverters are connected to the RS485_A1 and RS485_B1 ports of the eManager, both the two must be added to the **RS485_1** setting area.
- To remove an added inverter, tap .

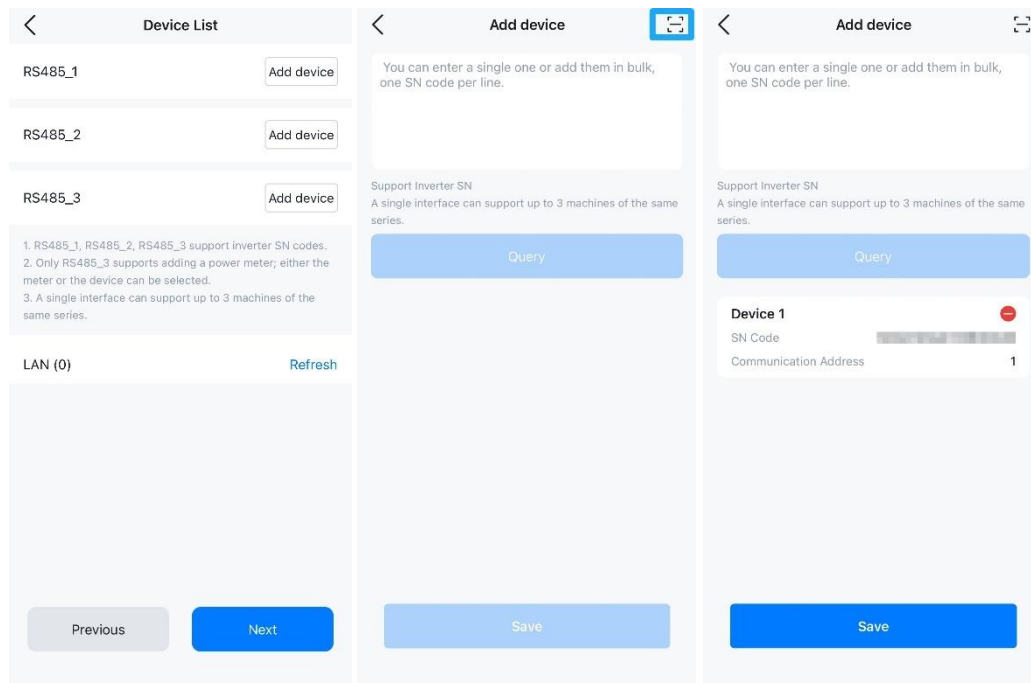

- LAN paralleling connection

Tap **Refresh** in the **LAN** setting area to display the connected devices.

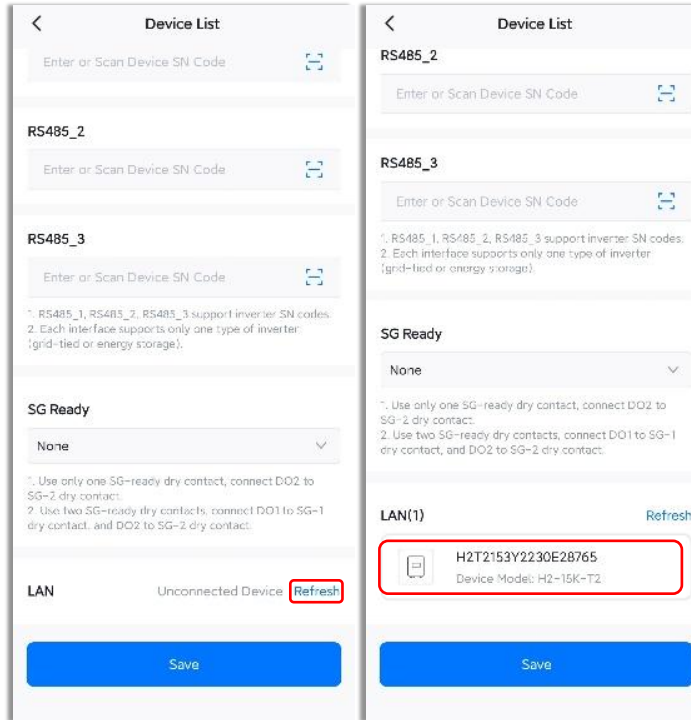

5. Wiring method

If you choose **External CT**, select the ratio of the CT(s) used in your system.

Electricity meter wiring method

Wiring

A three-phase four-wire meter

CT Channel

Internal CT

System Schematic

Previous Next

Electricity meter wiring method

a single phase electricity meter

CT Channel

Internal CT

System Schematic

Previous Next

Electricity meter wiring method

A three-phase four-wire meter

CT Channel

External CT

CT Transformation Ratio

100A/50mA

System Schematic

100A/50mA ✓

250A/50mA

500A/50mA

100A/40mA



6. Policy configuration

By default, **Current policy** is set to **Peak clipping and valley filling**. If you need to change it, contact SAJ for consultation.

< Policy configuration [Template](#)

Current strategy Peak shaving and valley filling

temporal strategy weekly

week strategy

Mon. Please select

Tue. Please select

Wed. Please select

Thu. Please select

Fri. Please select

Saturday Please select

Sunday Please select

Previous Next

- a. To create a policy, tap **Template** on the upper right corner. Tap **Local addition**.

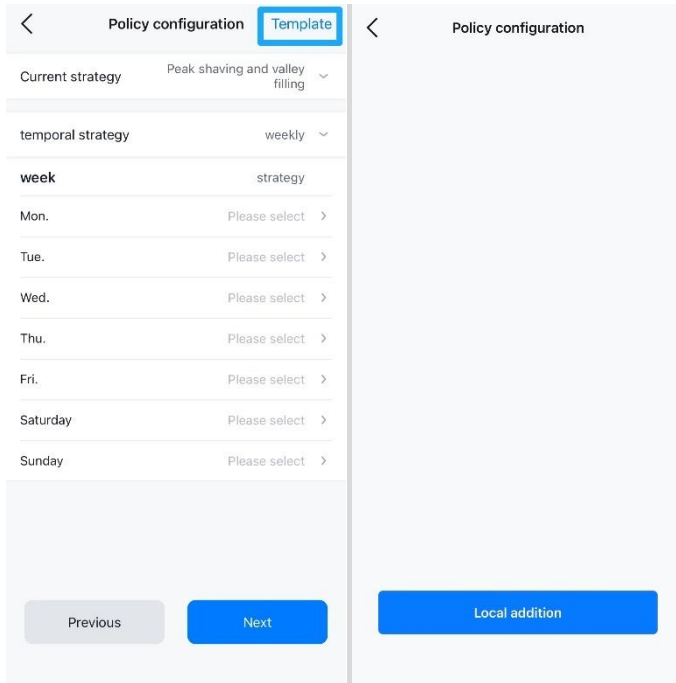

- I. Name the policy. In the following screenshot, **Test** is used as an example.
- II. In the **Priority strategy** setting area, enable or disable the following functions:
 - **SOC Protection:** If enabled, set the battery SOC (upper threshold for charging and lower threshold for discharging) to prevent battery over-charging or over-discharging.
 - **Grid Import Limitation:** If enabled, set the upper threshold for the system input from the grid.
 - **Back-up mode:** If enabled, set the backup SOC threshold, which must be higher than the lower threshold for discharging that you set in **SOC Protection**.
 - **Self-Consumption Mode:** It is suggested that you enable this function.
- III. In the **Time sharing strategy** setting area, per your needs, set **Charge**, **Discharge**, or **Standby** for different periods in each day.

Notes:

- You can set a maximum of 12 periods for one day and set different work statuses (charging, discharging, and standby) for each period.
- The charging and discharging power set in this step will apply to the whole system.
- If **Self-Consumption mode** is enabled, the inverter works in the self-consumption mode in standby status.

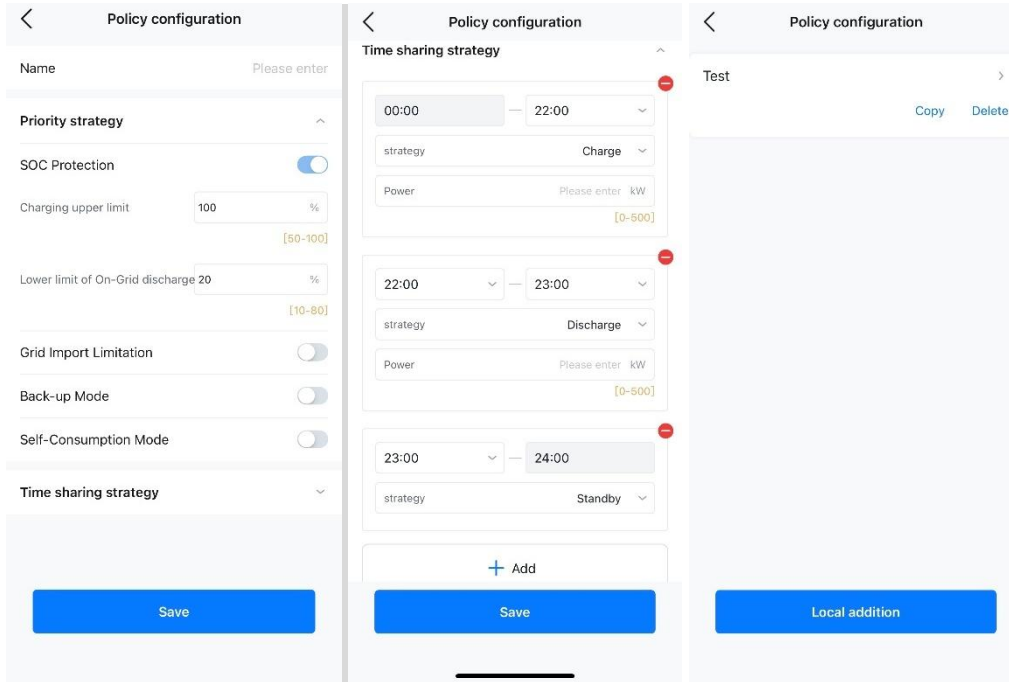

b. To apply policies, select **weekly** or **monthly** for **temporal strategy**.

- **weekly**: Set a policy for each week.
- **monthly**: Set a policy for each month.
 - **No impact**: One policy is used in working days and weekends for a month.
 - **Working days, weekends**: Different policies can be used in working days and weekends for a month.
 - **Working days, Saturdays, Sundays**: Different policies can be used in working days, Saturdays, and Sundays for a month.

The image displays two side-by-side screenshots of a 'Policy configuration' interface. Both screenshots show a 'Current strategy' of 'Peak shaving and valley filling' and a 'temporal strategy' dropdown menu set to 'weekly'. The left screenshot has a blue box around the 'temporal strategy' dropdown. Below the dropdowns, there is a 'week' section with a 'strategy' dropdown and four days (Mon., Tue., Wed., Thu.) each with a 'Please select' dropdown. At the bottom are 'Cancel' and 'Save' buttons. The right screenshot shows the 'temporal strategy' dropdown menu closed, with 'monthly' selected. Below this, there is an 'influence factor' section with three options: 'No impact', 'Working days, weekends', and 'Working days, Saturdays, Sundays'. At the bottom are 'Cancel' and 'Save' buttons.

- c. Tap a period to select the policy for it. You can select **Single modification** to set the policy for each period one by one; or you can select **Modify all** to apply the same policy to all periods.

The image displays three sequential screenshots of a mobile application interface for policy configuration.

- Left Screenshot:** Titled "Policy configuration" with a "Template" link. It shows a "Current strategy" of "Peak shaving and valley filling" and a "temporal strategy" of "monthly". Below, a "month" selection screen is shown with a grid of months (Jan., Feb., Mar., Apr., May) and days (Weekday, Weeke...). The "Weekday" and "Weeke..." options for January are highlighted with a blue box.
- Middle Screenshot:** Similar to the first, but the "Weekday", "Saturd...", and "Sunday" options for January are highlighted with a blue box.
- Right Screenshot:** Titled "strategy". It shows an "Application scope" dropdown menu with "Single modification" selected. Below, there is a "selection strategy" section. At the bottom, there are three buttons: "Single modification" (highlighted in blue), "Modify All", and "Cancel".



7. Export limitation settings

If **Export limitation** is enabled, set **Selling Power Limit**.

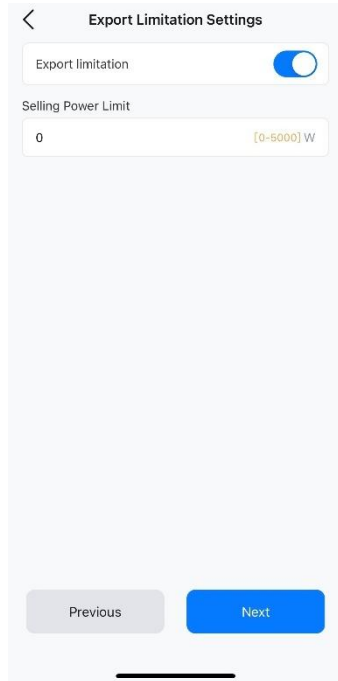

8. Safety settings

a. Select **Country** and **Grid Compliance**.

For **Grid Compliance**, select the value according to your setpoint (region of installation).

Taking Australia as an example:

- **AS4777_AustraliaA**: For large interconnected power systems. For example, all Australian networks other than those specified below.
- **AS4777_AustraliaB**: For small interconnected power systems. For example, Western Power.
- **AS4777_AustraliaC**: For isolated or remote power systems. For example, Horizon Power and TasNetworks.

b. Tap **Auto Time Sync** to set the device time to the time zone of the selected country or region.

c. Tap **Next** to wait for the initialization take effect.

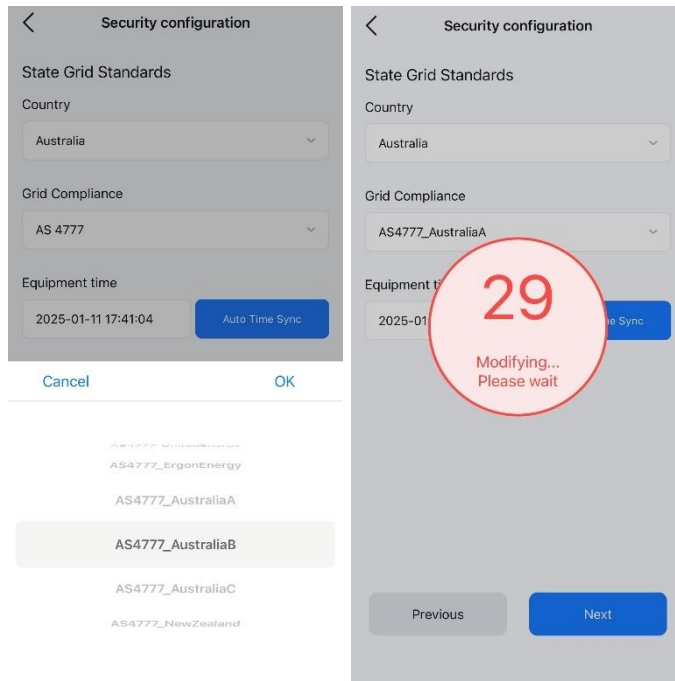

6.4. View the EMS settings

After the initialization is completed, view the EMS settings for double check, especially check the followings:

1. Tap the eManager to view its information.
 - **Basic information:** You can view the detailed information as shown below.

Note: Make sure that **Connect** is **up**. If **Router Signal** is lower than -70 dBm, it is recommended to use Ethernet connection manner.
 - **Module event:** You can view the history events reported.

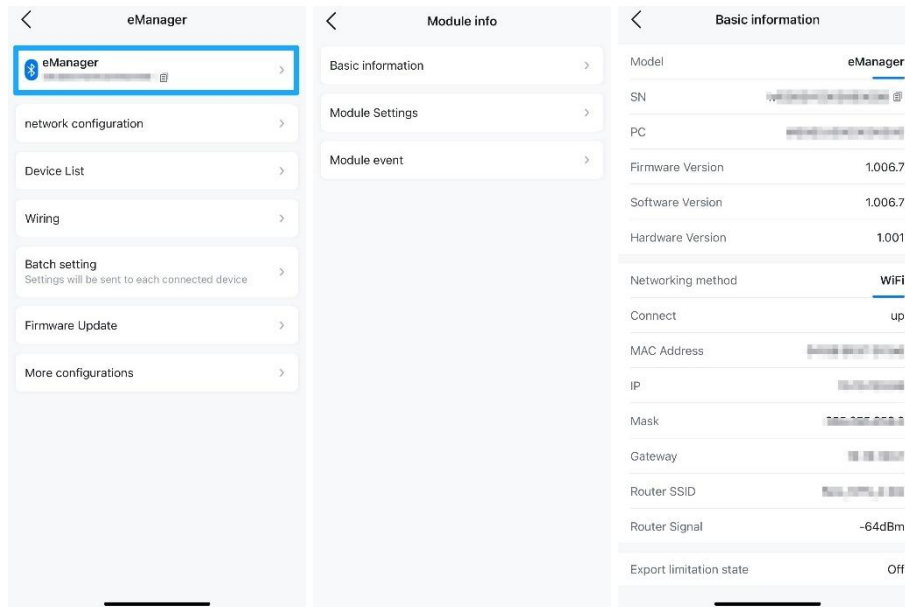

- **Module settings:** You can view or change the current node and the interval for reporting events.

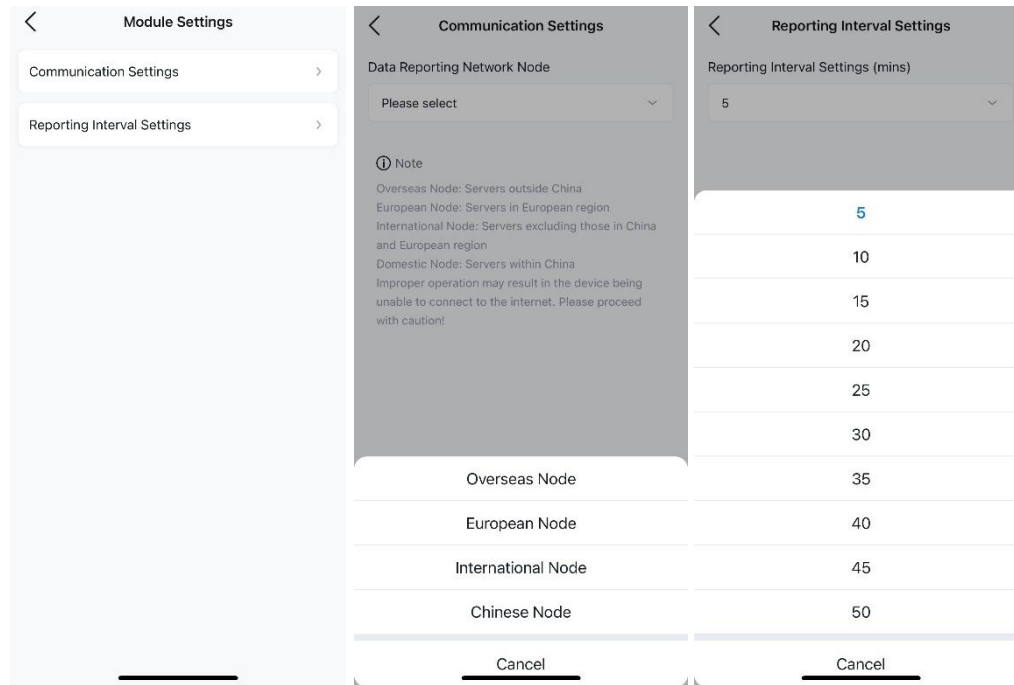



2. Choose **Network configuration** > **Network Diagnosis** to verify that the network connection is normal.
3. Tap **Device List** and verify that all required devices are added.
If you need to change the default settings of the **Battery brand** and **Lower limit of battery charging capacitance (off-grid)** parameters, tap the required device in **Device list**, set the values, and save the changes.
4. Tap **Wiring** to view or change the connection manner.
5. Tap **Batch setting**.
 - **Safety Settings:** View or change the country and grid compliance.
 - **Policy configuration:** View or change the policies for each period.
 - **Export Limitation Settings:** View or change the export limitations.

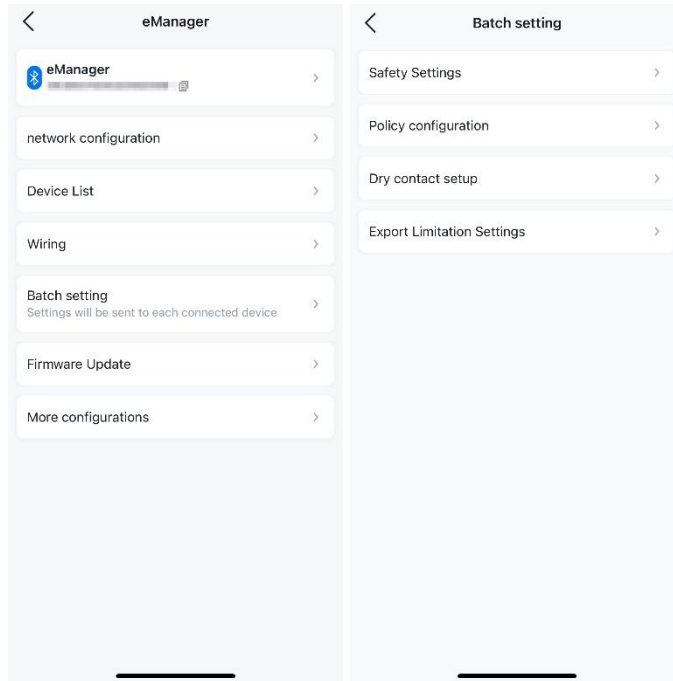

6.5. Set the dry contact function

If you have connected an external device to a pair of DO ports on the eManager, enable the dry contact as follows:

1. On the eManager device page, tap **Dry contact setup**. Enable the dry contact function. Tap **Save**.

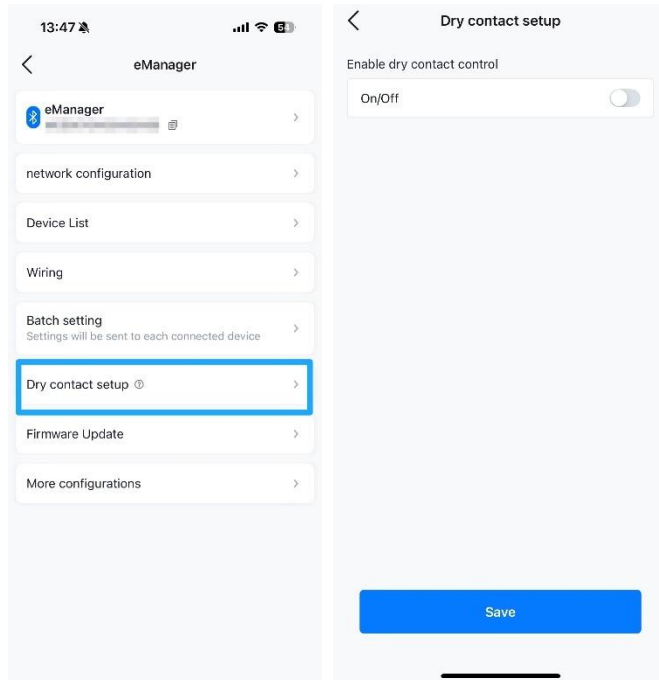

2. On the detailed setting page, select the required DO port pair:

- **DO1 on/off control:** DO NO1 and DO COM1
- **DO2 on/off control:** DO NO2 and DO COM2

Note: The dry contact function can only be set for one pair of DO ports.

← Dry contact setup

Enable dry contact control

On/Off

Control dry contact ⓘ

Control mode DO2 on/off control ▾

Open task hold time ⓘ

5 [1-720] min

Close task hold time ⓘ

5 [1-240] min

Task Settings [Add Task](#) [Edit](#)

19:00-19:59 >
Execution Time: Mon, Tue.

07:00-09:30 >
Execution Time: Sunday, Mon, Tue, Wed, Thu, Saturday

DO1 on/off control



DO2 on/off control

[Cancel](#)

3. Task Settings

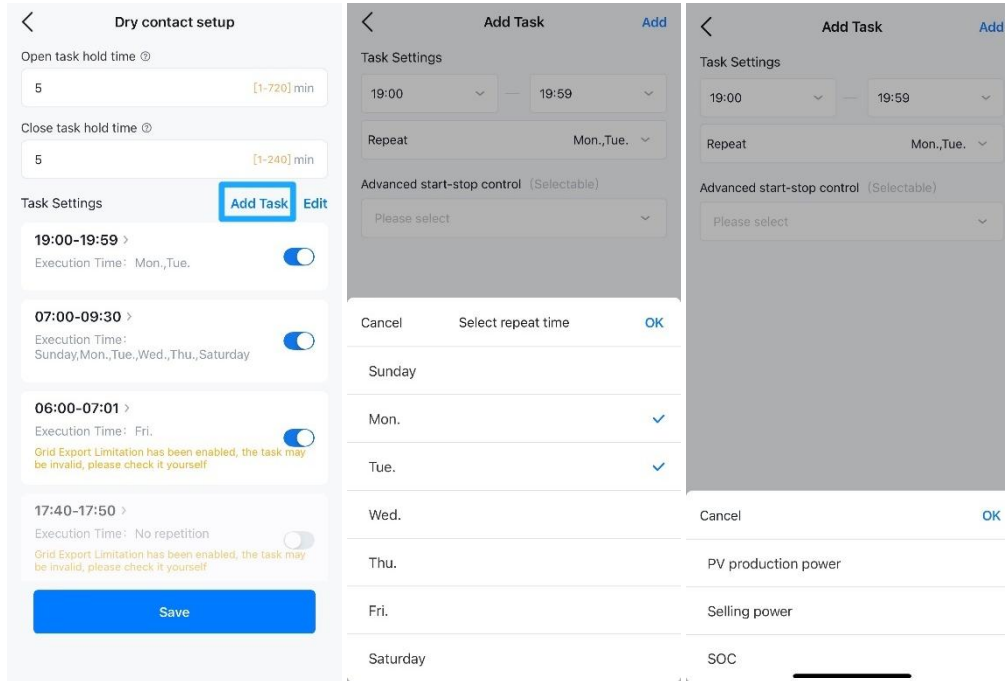
- To add a task, tap **Add Task** and set the time and start-stop control manner.



- To modify a task, tap the period to reset the time and start-stop control manner.
- To remove a task, tap the icon  of this task.
- To enable or disable a task, tap the icon  or  of this task.

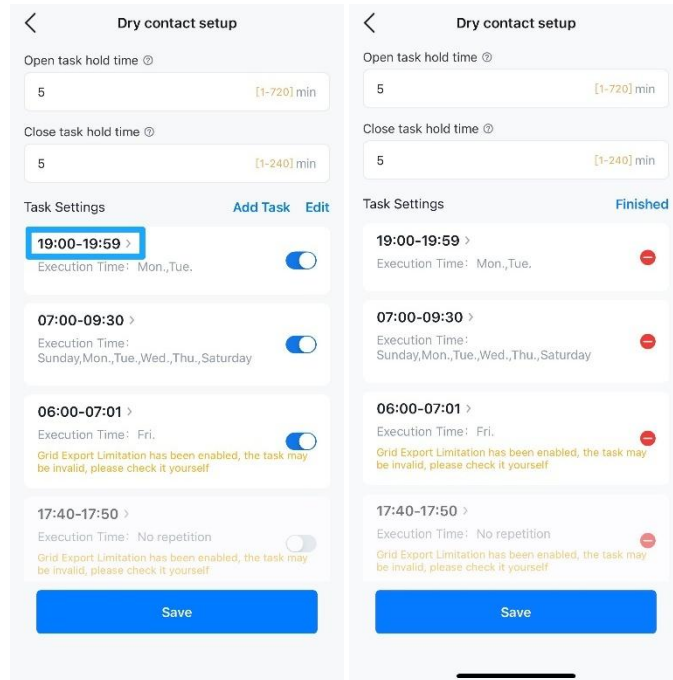

- Open task hold time:** Here takes the value **5 min** as an example.
Once a task starts, even if it is detected that the execution conditions of this task fail to be met, the task will stop only after five minutes. (The task execution conditions were set in **Task settings**.)
- Close task hold time:** Here takes the value **5 min** as an example.
After a task stops, even if the trigger conditions of any task are met, this task will not start until five minutes are passed. (The task trigger conditions were set in **Task settings**.)

Dry contact setup

Open task hold time ⓘ
5 [1-720] min

Close task hold time ⓘ
5 [1-240] min

Task Settings [Add Task](#) [Edit](#)

19:00-19:59 >
Execution Time: Mon.,Tue.

07:00-09:30 >
Execution Time: Sunday,Mon.,Tue.,Wed.,Thu.,Saturday

06:00-07:01 >
Execution Time: Fri.
Grid Export Limitation has been enabled, the task may be invalid, please check it yourself

17:40-17:50 >
Execution Time: No repetition
Grid Export Limitation has been enabled, the task may be invalid, please check it yourself

Save

6.6. View the inverter firmware version

1. On the inverter main page, tap **Device info**.
2. On **Basic info**, view the values of **Display Board Version (ARM)** and **Control Board Version (DSP)**.

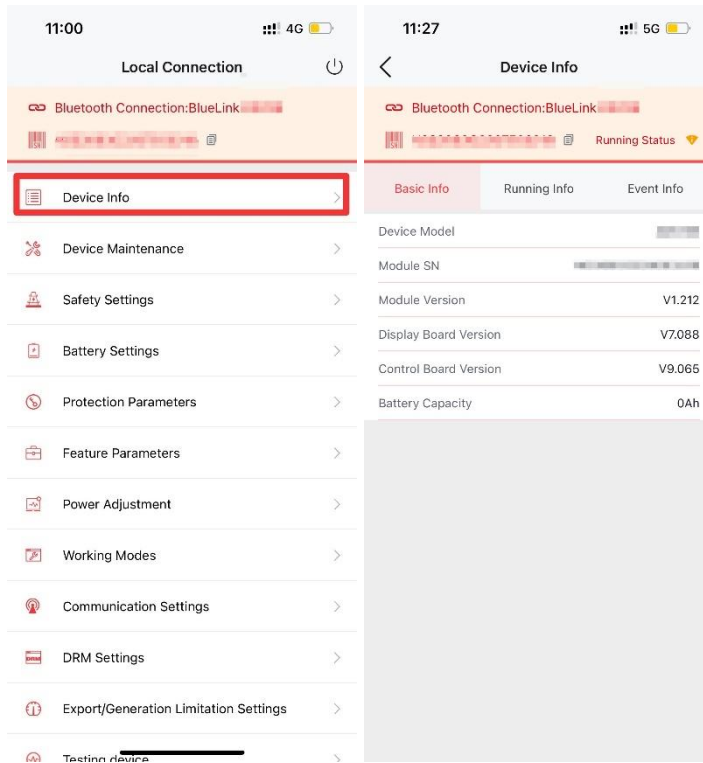

6.7. Create a plant

1. On the **Home** page, tap **Create Plant**. Select **Create Plant for Owner**.

Alternatively, on the **Management** page, tap the **+** icon on the top right corner and select **Create Plant for Owner**.

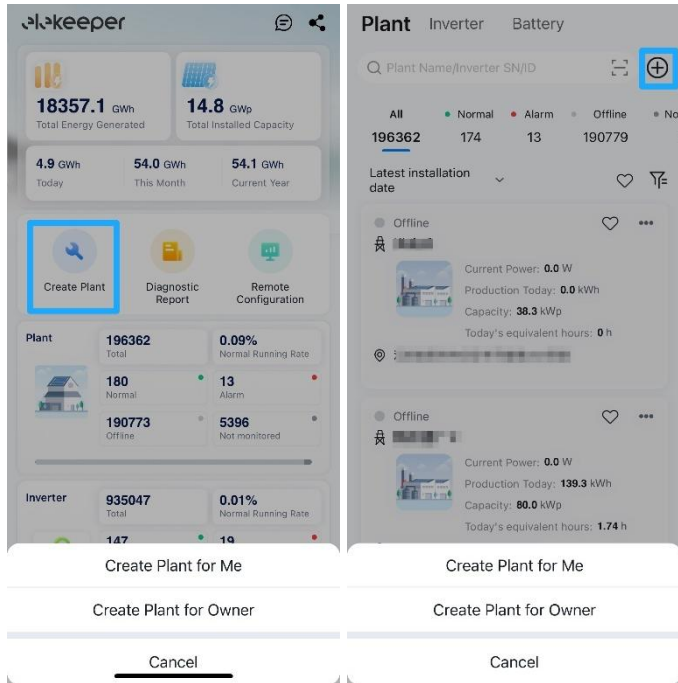

2. Apply for an account for the end user.
 - a. Tap **Register the owner's account**.
 - b. Set the required parameters based on the actual conditions of the end user.
 - c. Tap **Register**, **Create Plant for Owner**, and then **Register the owner's account**.

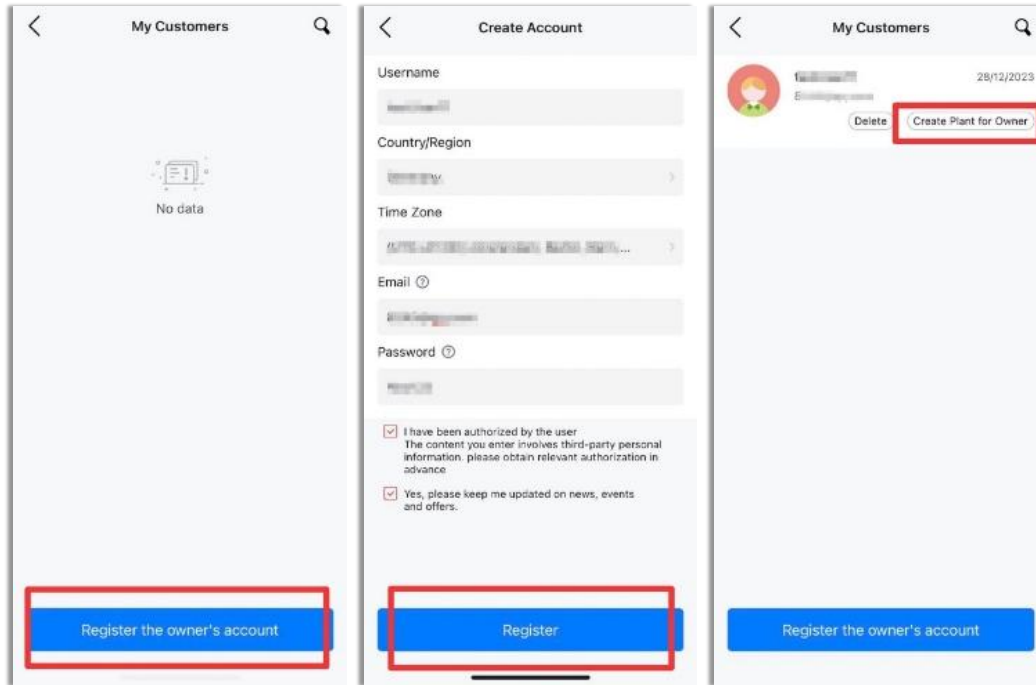

3. Configure the plant details based on your actual conditions.
 - a. Set the name, capacity, country or region, location, detailed address, user type, number of components, and PV panel azimuth. Tap **Create Plant**.
 - b. Scan the EMS SN to add the device. Double check whether all devices added to this EMS are displayed. If not, check whether there is any communication error occurs between the EMS and the inverter. Then, tap **Next**.

The image displays two sequential screenshots of a mobile application's 'Add' screen. The left screenshot, taken at 10:36, shows a form for creating a plant with fields for Plant Owner, Name (Test Demo Plant), Capacity (10 kWp), Country/Region (China), Location, Detailed Address, Use Type (Home Use), Number of Components, and PV Panel Azimuth. A red box highlights the 'Create Plant' button at the bottom right. The right screenshot, taken at 18:05, shows the same screen after scanning an EMS SN. The 'Name' field is replaced by 'Please enter the SN', and a 'Device 1' section is visible with fields for SN (HS) and Device Capacity (10 kWp). A red box highlights the 'Next' button at the bottom right.



7. Appendix

7.1. Recycling and disposal

This device should not be disposed as a residential waste.

The device that has reached the end of its operation life is not required to be returned to your dealer; instead, it must be disposed by an approved collection and recycling facility in your area.

7.2. Warranty

Check the product warranty conditions and terms on the SAJ website: <https://www.saj-electric.com/>

7.3. Contacting support

Guangzhou Sanjing Electric Co., Ltd.

Address: SAJ Innovation Park, No.9, Lizhishan Road, Guangzhou Science City, Guangdong, P.R.China.

Postcode: 510663

Website: <https://www.saj-electric.com/>

Technical Support & Service

Tel: +86-20-66608588

Fax: +86-20-66608589

E-mail: service@saj-electric.com

International Sales

Tel: +86-20-66608618/66608619/66608588/66600086

Fax: +86-20-66608589

E-mail: info@saj-electric.com

China Sales

Tel: 020-66600058/66608588

Fax: 020-66608589

7.4. Trademark

SAJ is the trademark of Sanjing.