

Smart Energy Controller

SEC3000C

User Manual

Copyright Statement

Copyright ©GoodWe Technologies Co., Ltd., 2025. All rights reserved.

No part of this document can be reproduced or transmitted to the public platform in any form or by any means without the prior written authorization of GoodWe.

Trademarks

GOODWE and other GoodWe trademarks are trademarks of GoodWe Company. All other trademarks or registered trademarks mentioned in this manual are owned by the respective company.

NOTICE

The information in this document is subject to change due to product updates or other reasons. This document cannot replace the product labels or the safety precautions unless otherwise specified. All descriptions in the document are for guidance only.

1 About This document



1.1 Overview

This document describes the product information, installation, electrical connection, commissioning, troubleshooting, and maintenance. Read through this document before installing and operating the product for the product features, functions, and safety precautions. This document is subject to update without notice. For more product details and latest documents, refer to <https://en.goodwe.com/>.

1.2 Applicable Model

This document applies to the Smart Energy Controller SEC3000C (SEC for short).

1.3 Symbol Definition

 DANGER
Indicates a high-level hazard that, if not avoided, will result in death or serious injury.
 WARNING
Indicates a medium-level hazard that, if not avoided, could result in death or serious injury.
 CAUTION
Indicates a low-level hazard that, if not avoided, could result in minor or moderate injury.
NOTICE
Highlight and supplement the texts, or some skills and methods to solve product-related problems to save time.

2 Safety Precaution

Please strictly follow these safety instructions in the user manual during the operation.



The equipment is designed and tested strictly in compliance with related safety rules. Read and follow all the safety instructions and cautions before any operations. Improper operation might cause personal injury or property damage as the equipment is an electrical equipment.

2.1 General Safety

NOTICE

- The information in this document is subject to change due to product updates or other reasons. This document cannot replace the product labels or the safety precautions unless otherwise specified. All descriptions in the document are for guidance only.
- Before installations, read through this document to learn about the product and the precautions.
- All installations should be performed by trained and knowledgeable technicians who are familiar with local standards and safety regulations.
- Use insulating tools and wear personal protective equipment (PPE) when operating the equipment to ensure personal safety. Wear anti-static gloves, cloths, and wrist strips when touching an electronic equipment to protect the equipment from damage.
- Unauthorized disassembly or modification may cause damage to the equipment, which is not covered within the warranty scope.
- Strictly follow the installation, operation, and configuration instructions in this document. The manufacturer shall not be liable for equipment damage or personal injury if you do not follow the instructions. For more warranty details, visit <https://en.goodwe.com/warranty>

2.2 Personnel Requirements

NOTICE

- Personnel who install or maintain the equipment must be strictly trained, learn about safety precautions and correct operations.
- Only qualified professionals or trained personnel are allowed to install, operate, maintain, and replace the equipment or parts.

2.3 Grounding Safety



Make sure the equipment is reliably grounded before operation.

2.4 Personal Safety



- Use insulating tools and wear personal protective equipment (PPE) when operating the equipment to ensure personal safety.
- Do not touch the equipment when it is short-circuited. Keep away from the equipment, and turn off the power immediately.
- Before wiring, disconnect all upstream switches to ensure the equipment is not powered on.

2.5 Equipment Safety



Make sure the equipment is installed at a solid and reliable place.







- Use appropriate tools for proper installation, maintenance, etc.
- Observe local standards and safety regulations when operating the equipment.
- Unauthorized disassembly or modification may cause damage to the equipment, which is not covered within the warranty scope.

2.6 Safety Symbols and Certification Marks



- All labels and warning marks must be clear and distinct after the installation. Do not block, alter, or damage any label.
- The following descriptions are for reference only.

No.	Symbol	Meaning
1		Potential risks exist. Wear proper PPE before any operations.

2		HIGH VOLTAGE HAZARD. Power off the equipment before any operations.
3		Read through the document before any operations.
4		Do not dispose of the equipment as household waste. Discard the product in compliance with local laws and regulations, or send it back to the manufacturer.
5		CE marking.

2.7 EU Declaration of Conformity

2.7.1 Equipment with Wireless Communication Modules

The equipment without wireless communication modules sold in the European market meets the requirements of the following directives:

- Radio Equipment Directive 2014/53/EU (RED)
- Restrictions of Hazardous Substances Directive 2011/65/EU and (EU) 2015/863 (RoHS)
- Waste Electrical and Electronic Equipment 2012/19/EU
- Registration, Evaluation, Authorization and Restriction of Chemicals (EC) No 1907/2006 (REACH)

2.7.2 Equipment without Wireless Communication Modules

The equipment without wireless communication modules sold in the European market meets the requirements of the following directives:

- Electromagnetic compatibility Directive 2014/30/EU (EMC)
- Electrical Apparatus Low Voltage Directive 2014/35/EU (LVD)
- Restrictions of Hazardous Substances Directive 2011/65/EU and (EU) 2015/863 (RoHS)
- Waste Electrical and Electronic Equipment 2012/19/EU
- Registration, Evaluation, Authorization and Restriction of Chemicals (EC) No 1907/2006 (REACH)

3 Product Introduction

3.1 System Overview

SEC is specified for the monitoring and management platform of PV power generation. It can be applied to collect data from devices in a PV power generation system, such as grid-tied PV inverters, hybrid inverters, smart meters, etc., store logs, and send data to the monitoring management platform for centralized monitoring, operation, and maintenance of the PV system.

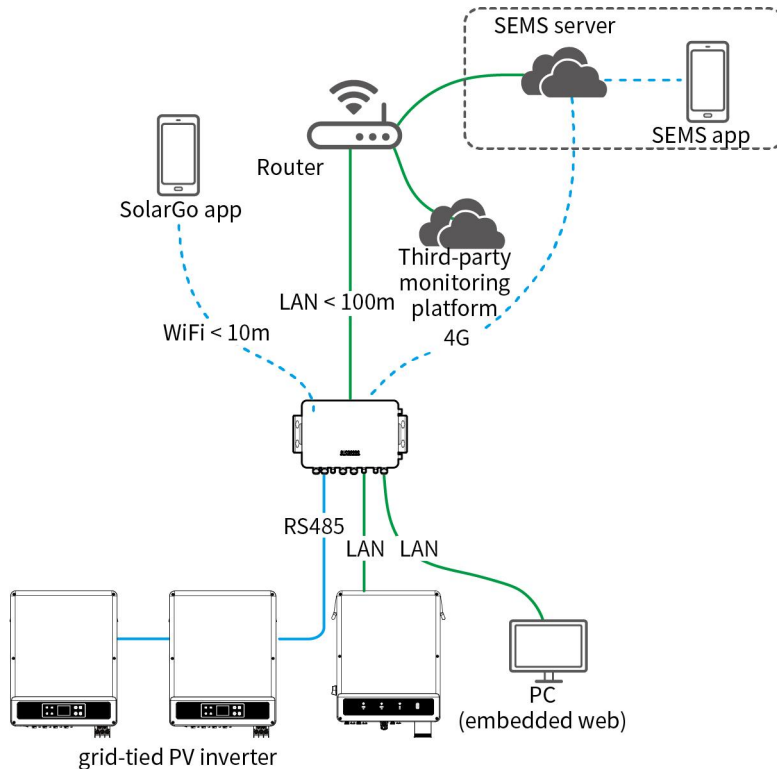

- A maximum of 20 inverters can be connected to one RS485 communication cable.
- A maximum of 10 hybrid inverters could be connected via LAN cable.

3.2 Circuit Diagram

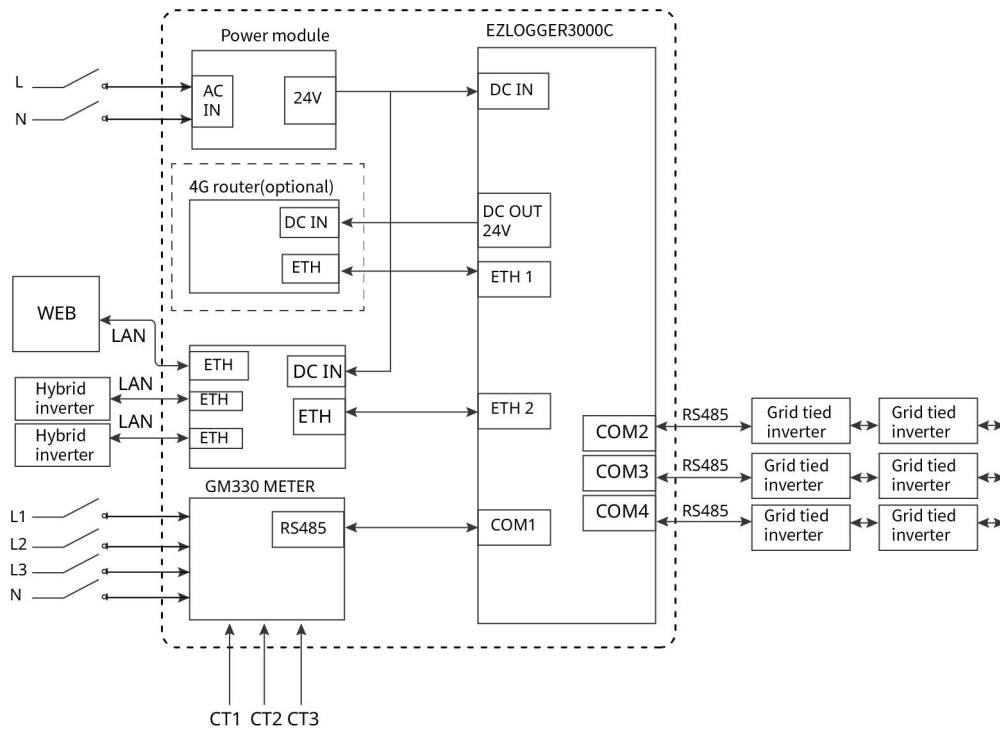

3.3 Model

The following model is involved in the document:

SEC3000C

1 2 3

No.	Meaning	Explanation
1	Product function	SEC: Smart Energy Controller
2	Code for generation	3000: the third generation
3	Scenario	C : Photovoltaic energy storage system in commercial and industrial applications

3.4 Appearance

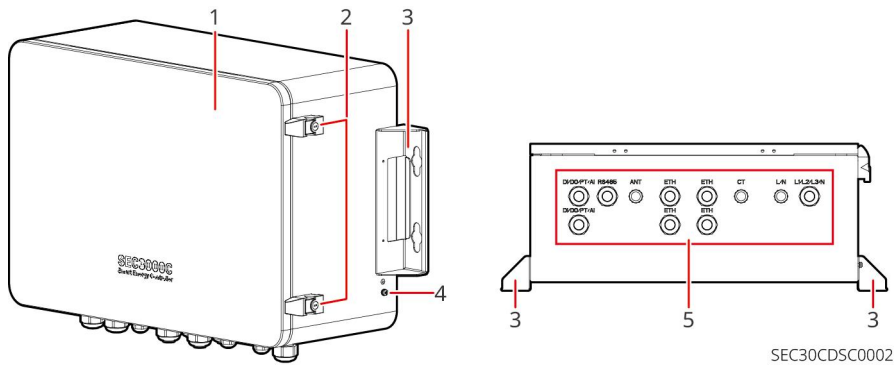

No.	Parts	No.	Parts
1	Cabinet door	2	Lock
3	Mounting plate	4	Grounding point
5	Cable hole	-	-

3.5 Parts Introduction

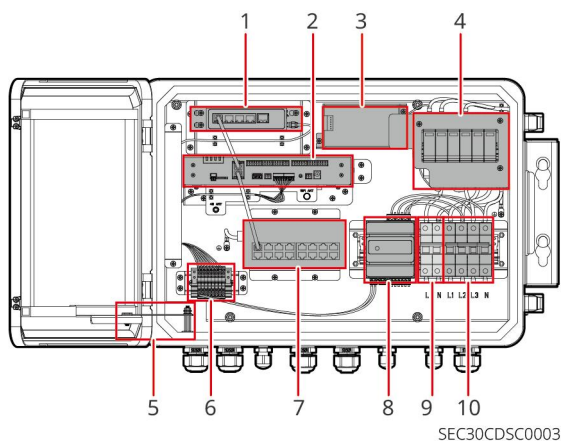

No.	Name	Description
1	4G router	<ul style="list-style-type: none"> Optional parts support purchase from GoodWe or be prepared by customers. A reserved DIN rail allows a self-purchased 4G router to be installed inside the SEC3000C enclosure. Recommended maximum dimensions: 185*80*155 mm; power supply: 24 V.
2	EzLogger	<ul style="list-style-type: none"> In-built smart data logger : EzLogger3000C. Collect the third-party equipment to the EzLogger for RCR and remote shutdown.

3	24 V power module	For powering EzLogger3000C inside SEC3000C and switch.
4	Lightning protection module	If the module is damaged, contact the after-sales service.
5	Limit lever	For fixing the cabinet door.
6	RS485 communication terminal.	<ul style="list-style-type: none"> ● It is connected to grid-tied PV inverters via the RS485 communication cable. A maximum of 20 inverters can be connected to one RS485 port. ● Currently supported inverters: the GT series inverters. Visit Compatibility list of GoodWe inverters and IoT products to check compatible inverters. ● A1 / B1 ports are occupied, and are connected to internal smart meters of SEC3000C in default.
7	Switch	<ul style="list-style-type: none"> ● Connected to smart dongles of hybrid inverters via network cables. A maximum of 10 hybrid inverters could be connected. ● Currently supported inverter: ET40-50kW series inverters. Visit Compatibility list of GoodWe inverters and IoT products to check compatible inverters. ● Currently supported smart dongle: WiFi / LAN Kit-20. Make sure the applicable version is V2.2.29 and later. The first three serial numbers are 721. ● Connected to the computer via the network cable and login to the embedded web, and commission the device.
8	Smart meter	<ul style="list-style-type: none"> ● In-built GoodWe smart meter: GM 330. ● For checking data of the on-grid point, and adjusting the power feed into the grid.
9	Single-phase circuit breaker	<ul style="list-style-type: none"> ● It is connected to the power grid via an AC cable to power on/off the SEC3000C system. ● Input voltage: 100 - 240 Vac.
10	Three-phase circuit breaker	<ul style="list-style-type: none"> ● It is connected to the power grid via an AC cable to power on/off smart meter inside the SEC3000C. ● When connected to a three-phase four wire power grid, the supported input voltage range: line voltage 172 - 817 Vac.



- When connected to a three-phase three wire power grid, the supported input voltage range: line voltage 100 - 472 Vac.

3.6 Dimensions

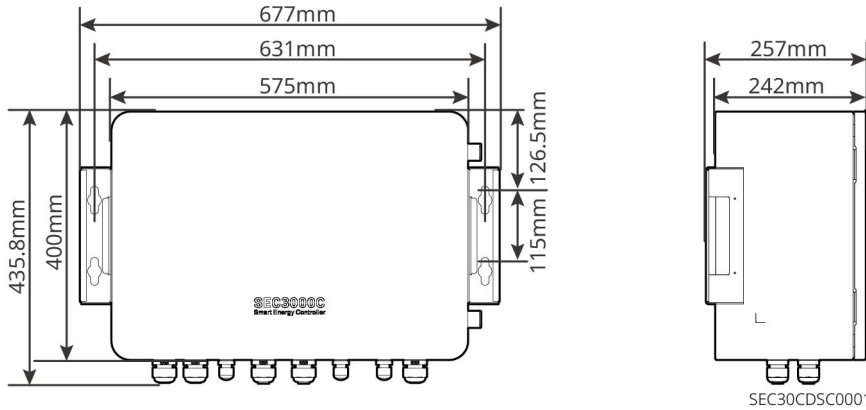

3.7 Indicators





Check the LED of the in-built data logger and smart meter of SEC3000C.

EzLogger3000C

Status	Status	Description
PWR		Steady green: The device is powered on.
		Green off: The device power supply is abnormal.
RUN		Steady green/Green off: The device fails to work.
NET		Slow blinking green: The device is working properly.
		Fast blinking green: Communication between the device and the router is normal, but communication between the device and the server fails.
		Slow blinking green: Communication between the device and the router fails.
ALM		Steady red: All the connected inverters are in fault status.
		Fast blinking red: the equipment is being upgraded.
		Red off: At least one inverter in the system is working

properly.

Smart meter

Type	Status	Description
Power indicator light 	On	The smart meter is powered on. No RS485 communication.
	Blink	The smart meter is powered on. Normal RS485 communication.
	Off	The smart meter is powered off.
Communication light 	Off	Reserved
	Blink	Press the Reset button for at least more than 5 seconds, power light, purchasing or selling electricity indicator light flash: reset the meter.
Purchasing or selling electricity indicator light 	On	Import from the grid.
	Blink	Export to the grid.
	Off	No purchasing or selling.
	Reserved	

3.8 Nameplate

Product: Smart Energy Controller Model: SEC3000C		Product type and model
Input	U _{AC} :***-***V _{a.c.}	Technical parameters
	P _{AC,r} :≤**W	
	f _{AC,r} :**/**Hz	
T _{operating} : -30-60°C, IP65, Protective Class I		
		Safety symbols
S/N		
GOODWE Manufacturer: GoodWe Technologies Co., Ltd. E-mail: service@goodwe.com No.90 Zijin Rd., New District, Suzhou, 215011, China Importer: GoodWe Europe GmbH (Only For Europe) Kistlerhof Str. 170, 81379 Munich, Germany Made in China		GW trademark, manufacturer and contact information

4 Check and Storage

4.1 Check the Equipment

Check the following items before receiving the product:

1. Check the outer packing box for damage, such as holes, cracks, deformation, and others signs of equipment damage. Do not unpack the package and contact the supplier as soon as possible if any damage is found.
2. Check the product model. If the inverter model is not what you requested, do not unpack the product and contact the supplier.





4.2 Deliverables





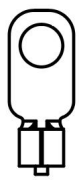

WARNING

- Check the deliverables for correct model and quantity, and intact appearance. Contact the supplier as soon as possible if any damage is found.
- After being taken out of the package, it is forbidden to put deliverables in rough, uneven or sharp places to prevent peeling paint.

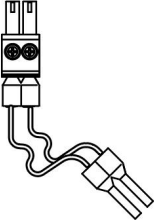
NOTICE

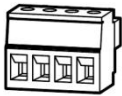
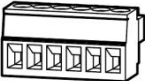
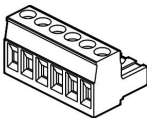
*4G antenna: optional.

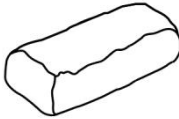
Parts	Description	Parts	Description
	Smart Energy Controller x 1		M12 expansion x 4
	M10 assembly bolt and nut x 4		Tube terminal x 20
	Tube terminal x 6 L1/L2/L3/N		The grounding OT terminal x 1

	Key x 4		4G router power cable x 1 Only applicable to scenes in which 4G routers are not applied.
	2PIN communication terminal x 4		4PIN communication terminal. x 4
	6PIN communication terminal. x 2		6PIN x 1 Applicable to smart meter CT.
	4G antenna x 1 (optional)		Fireproofing mud x 1
	Document x 1	-	-

4.3 Check and Storage

If the equipment is not to be installed or used immediately, please ensure that the storage environment meets the following requirements. After being stored for a long period, the equipment needs to be checked by professionals before use.

Time requirements:

- If the inverter has been stored for more than two years or has not been in operation for more than six months after installation, it is recommended to be inspected and tested by professionals before being put into use.
- To ensure good electrical performance of the internal electronic components of the inverter, it is recommended to power it on every 6 months during storage. If it has not been powered on for more than 6 months, it is recommended to be inspected and tested by professionals before being put into use.

Package requirements:

Do not unpack the outer package or throw the desiccant away.

Installation Environment Requirements :

- Place the equipment in a cool place away from direct sunlight.
- Store the equipment in a clean place. Make sure the temperature and humidity are appropriate and no condensation. Do not install the equipment if the ports or terminals are condensed.

- Keep the equipment away from flammable, explosive, and corrosive matters.

Stacking Requirements:

- Stack the equipment complying with the labels and requirements on the packing box.
- The equipment must be stacked with caution to prevent them from falling.

5 Installation



Install and connect the equipment with the deliverables included in the package. Otherwise, the manufacturer shall not be liable for the damage.

5.1 Installation

5.1.1 Installation Requirements

1. Do not install the equipment in a place near flammable, explosive, or corrosive materials.
2. The temperature and humidity at the installation site should be within the appropriate range.
3. Do not install the equipment in a place that is easy to touch, especially within children's reach.
4. It is recommended to install the equipment in a sheltered place. Build a sunshade if it is needed.
5. The place to install the equipment shall be well-ventilated for heat radiation and large enough for operations.
6. The equipment with a high ingress protection rating can be installed outdoors.
7. Install the equipment at a height that is convenient for operation and maintenance, electrical connections, and checking indicators and labels.
8. Equipment installation altitude needs to be lower than the maximum working altitude.
9. Install the equipment away from electromagnetic interference. If there are radio stations or wireless communication equipment below 30 MHz near the installation location, the distance between the equipment and the wireless electromagnetic interference equipment needs to exceed 30m.

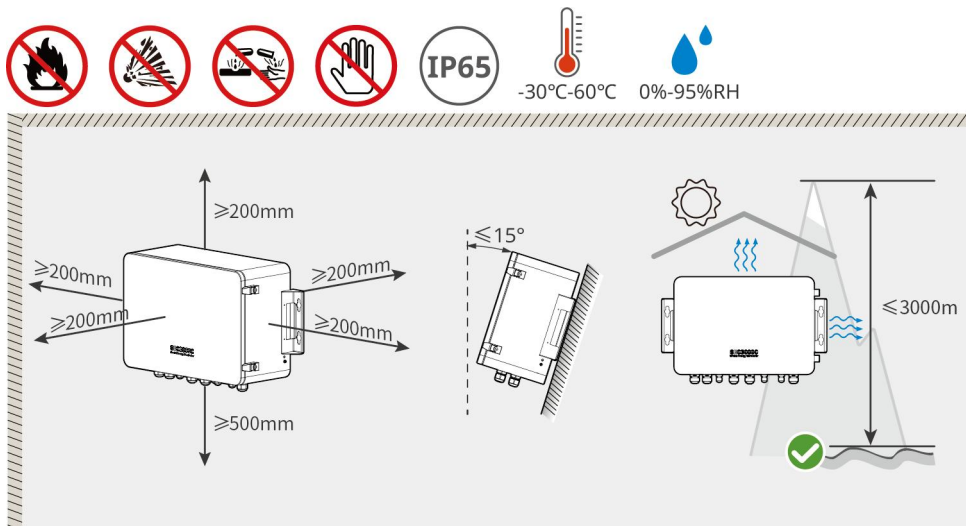

SEC30CINT002







5.1.2 Installation Tool Requirements

NOTICE

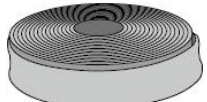

The following tools are recommended when installing the equipment. Use other auxiliary tools on site if necessary.

Installation Tool

Type	Description	Type	Description
	Diagonal pliers		Crimping tool
	Wire stripper		Open-end wrench
	Hammer drill ($\Phi 15\text{mm}$)		Torque wrench M4、 M5、 M7
	Rubber hammer		Socket wrench

	Marker		Multimeter Range $\leq 1100V$
	Heat shrink tube		Heat gun
	Cable tie		Vacuum cleaner
	Level	-	-

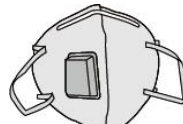
Personal Protective Equipment

Type	Description	Type	Description
	Insulation gloves and safety gloves		Dust mask
	Goggles		Safety shoes

5.2 Installation

CAUTION

- Avoid the water pipes and cables buried in the wall when drilling holes.
- Wear goggles and a dust mask to prevent the dust from being inhaled or contacting eyes when drilling holes.
- Make sure the device is firmly installed in case of falling down.

Wall-mounted installation

Step 1 Put the equipment on the wall horizontally and mark positions for drilling holes.

Step 2 Drill holes with hammer drill, and install expansion bolts.

Step 3 Mount the equipment onto the expansion bolt, and use torque wrench to tighten the expansion bolts.

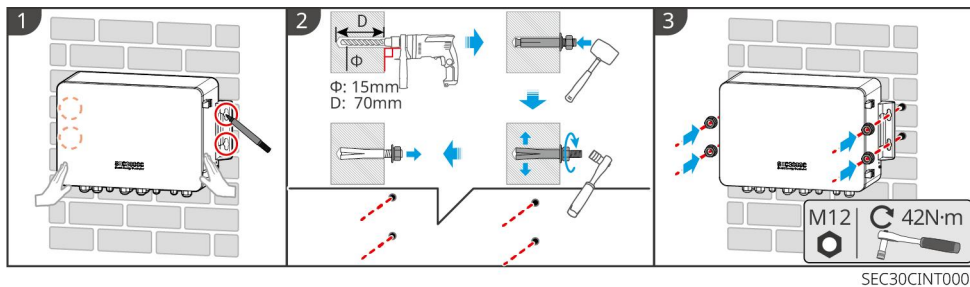

Bracket-mounted Installation

NOTICE

When applying this method, you need to prepare bracket in appropriate size.

Step 1 Confirm the mounting hole position of the bracket and mark positions for drilling holes.

Step 2 Drill holes with hammer drill.

Step 3 Mount the equipment onto the bracket with assembly bolts and nuts, and use torque wrench to tighten the bolts.

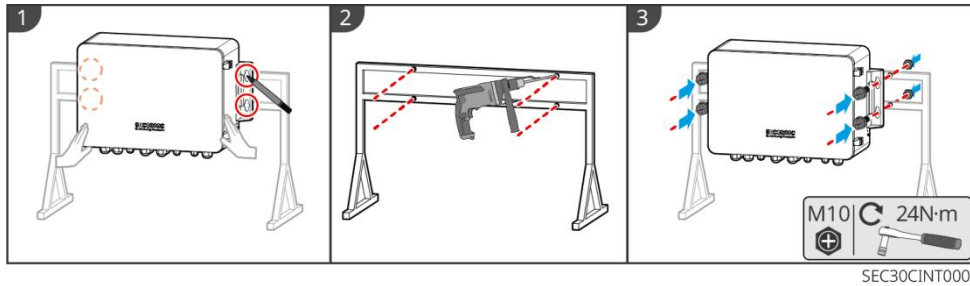

Pole-mounted Installation

NOTICE

When applying this method, prepare the necessary pole mounting accessories in appropriate size.

Step 1 Secure the pole mounting accessories to the mounting pole, and use torque wrench to tighten the bolts.

Step 2 Mount the equipment onto the pole with assembly bolts and nuts, and use torque wrench to tighten the bolts

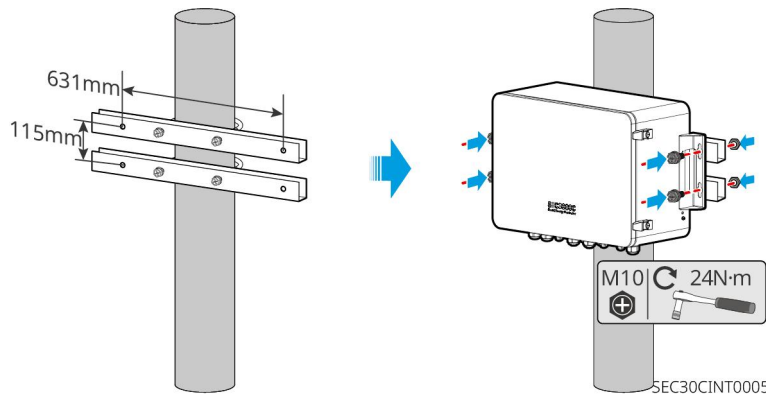

6 System Wiring



- Perform electrical connections in compliance with local laws and regulations, including operations, cables, and component specifications.
- Before electrical connections, disconnect all upstream switches to ensure the device is not energized. Do not work with **POWER ON**. Otherwise, an electric shock may occur.
- Tie the same type cables together, and place them separately from cables of different types. Do not place the cables entangled or crossed.
- If the cable bears too much tension, the connection may be poor. Reserve a certain length of the cable before connecting it to the equipment.
- When crimping the terminals, ensure that the conductor part of the cable is in full contact with the terminals. Do not crimp the cable jacket with the terminal. Otherwise the inverter equipment may not operate, or its terminal block may be damaged due to heating because of unreliable connection after operation.

NOTICE

- Wear personal protective equipment like safety shoes, safety gloves, and insulating gloves during electrical connections.
- All electrical connections should be performed by qualified professionals.
- Cable colors in this document are for reference only. The cable specifications shall meet local laws and regulations.

6.1 System Wiring Diagram

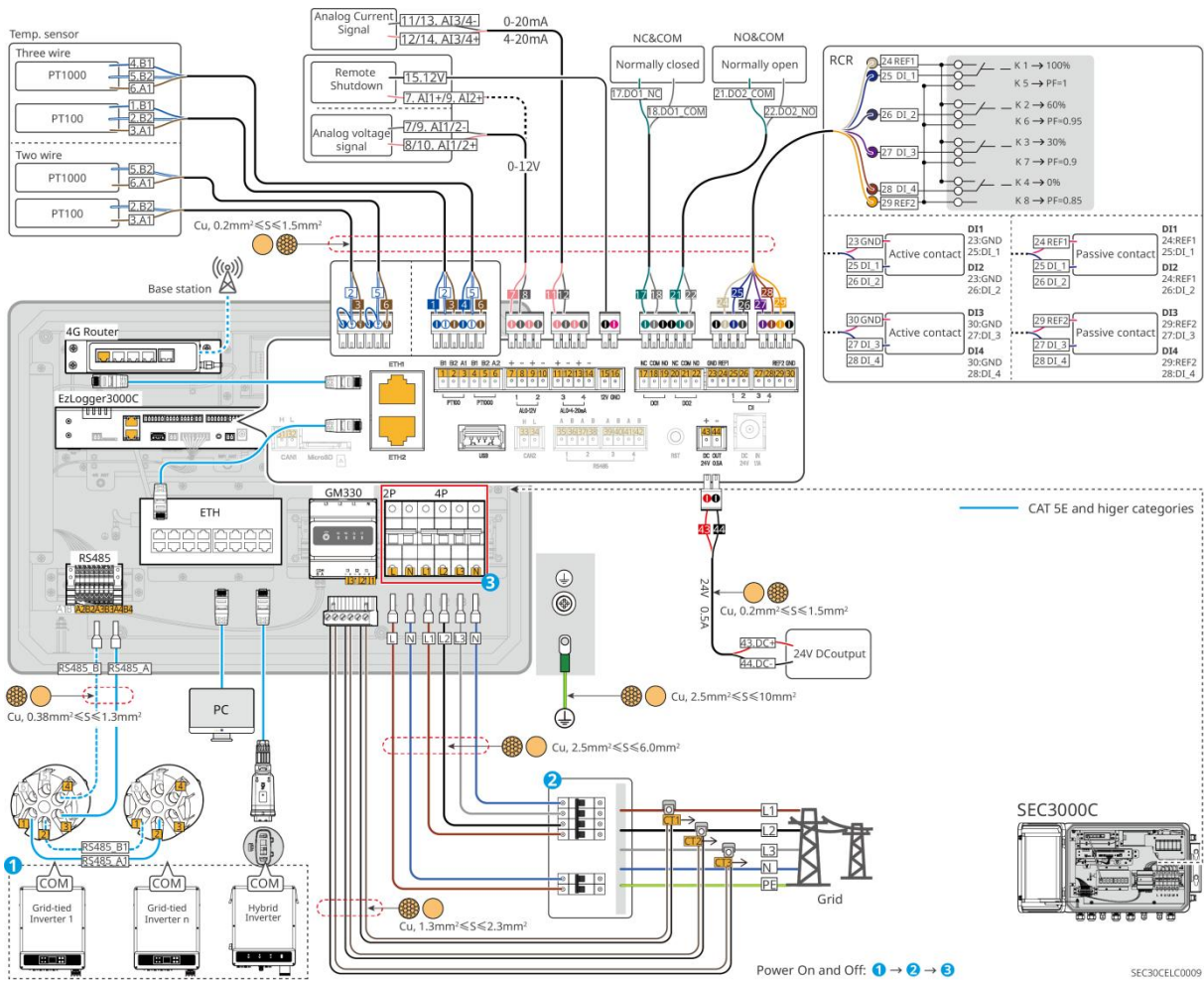

- Active and reactive power adjustment value of RCR devices in the wiring diagram are default values. For specific values, refer to the actual needs of the grid company.

6.2 Prepare Materials

Preparing Cables

No.	Cable	Recommended specifications	Acquisition method
1	PE Cable	<ul style="list-style-type: none"> ● Outdoor single core copper cable ● Cross-sectional area: 2.5 - 10 mm² ● Outer diameter : 2.5 - 4.5 mm 	Prepared by customers
2	Smart meter CT cable	<ul style="list-style-type: none"> ● Outdoor single core copper cable ● Cross-sectional area: 1.3 - 2.3 mm² 	Prepared by customers

		<ul style="list-style-type: none"> ● Outer diameter : 2.0 - 3.0 mm 	
3	Single-phase AC cable	<ul style="list-style-type: none"> ● Outdoor single core copper cable ● Cross-sectional area: 2.5 - 6.0 mm² 	Prepared by customers
4	Three-phase AC cable	<ul style="list-style-type: none"> ● Outer diameter : 2.5 - 4.0 mm 	Prepared by customers
5	RS485 communication cable of external equipment	<ul style="list-style-type: none"> ● Shielded twisted pair cable that meets local standards ● Cross-sectional area: 0.07 - 1.3 mm² ● Outer diameter : 1.0 - 2.5 mm 	Prepared by customers
6	Ethernet cable for external equipment	<ul style="list-style-type: none"> ● Shielded network cable: CAT 5 and above standard network cable and RJ45 shielded connector ● Length of network cable: no more than 100 m 	Prepared by customers

Opening the cabinet door and remove plate in wiring area

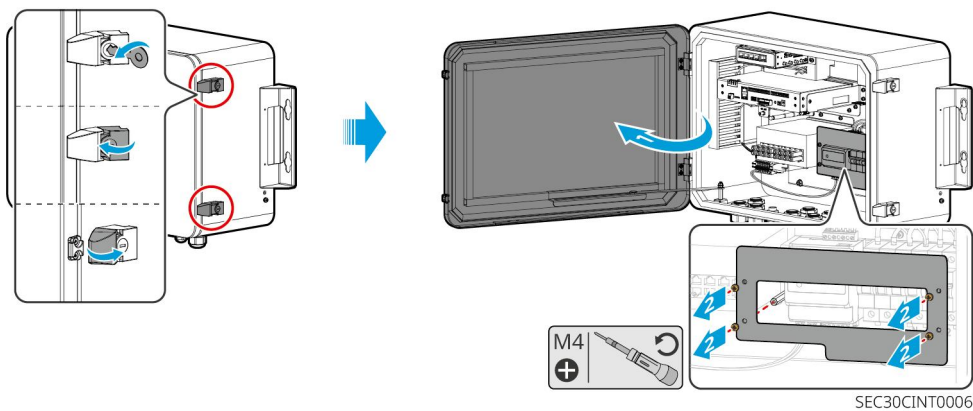

Cable hole

NOTICE

To ensure proper sealing, after installing the cable gland at the wire hole, seal it with fireproof putty mud.

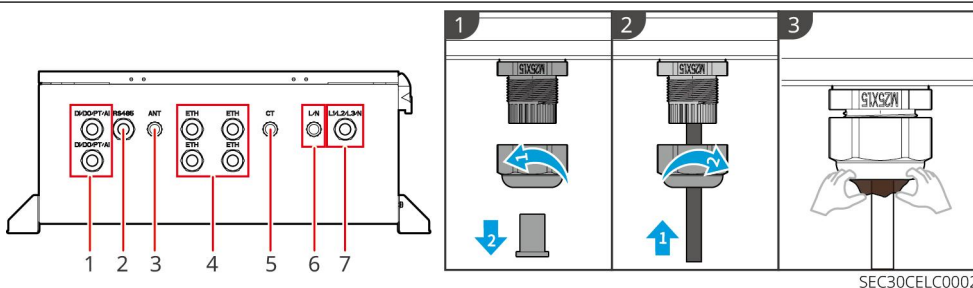

No.	Silkscreen	Description
1	DI/DO/PT/AI	Cable hole of DI/DO/PT/AI communication cable
2	RS485	Cable hole of RS485 communication cable
3	ANT	Cable hole of the antenna
4	ETH	Cable hole of the network cable
5	CT	Cable hole of the smart meter CT
6	L/N	Single-phase AC cable hole
7	L1/L2/L3/N	Three-phase AC cable hole

6.3 Connect the PE Cable

! WARNING

- When installing the equipment, the grounding cable must be installed first; when removing the equipment, the grounding cable must be removed last.
- To improve the corrosion resistance of the terminal, it is recommended to apply silica gel or paint on the grounding terminal after installing the PE cable.

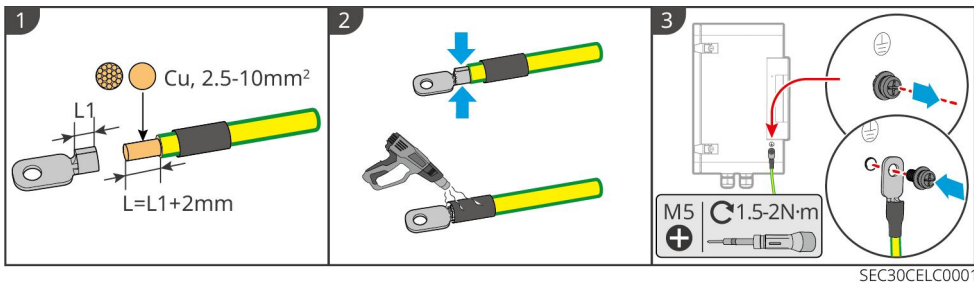

6.4 Single-phase AC Cable

NOTICE

Input voltage: 100 - 240 Vac.

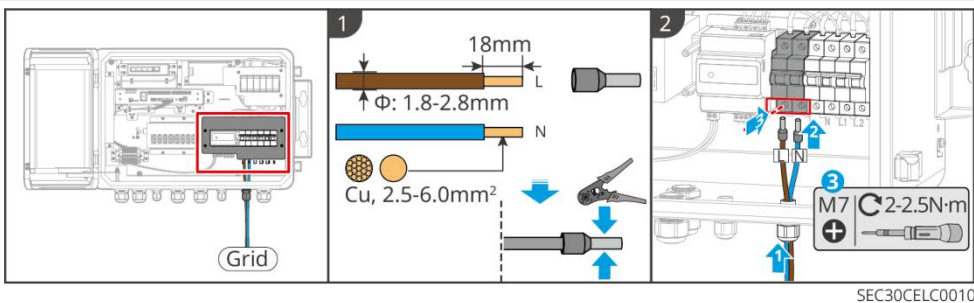

6.5 Three-phase AC Cable

NOTICE

Support connecting three-phase three wire system or three-phase four wire system. If you need to connect three-phase three wire system, please short circuit L2 and the neutral (N) wire.

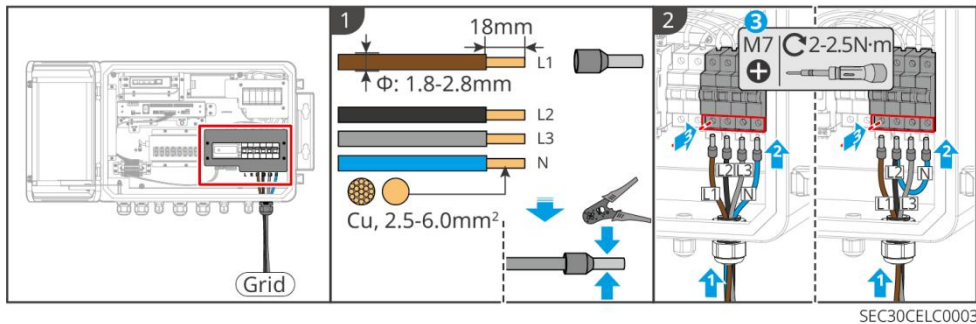

6.6 Smart Meter CT Cable

! WARNING

In areas at risk of lightning, if the meter cable exceeds 10m and the cables are not wired with grounded metal conduits, it is recommended to use an external lightning protection equipment.

NOTICE

- In-built smart meter of SEC: GM330.
- You can purchase it from GoodWe or prepare by yourself. CT ratio requirement: nA /5A.
 - nA : primary current input of the CT (range of n: 200 - 5000).
 - 5A: secondary current output of the CT.
- Ensure that the CT is connected in the correct direction and phase sequences, otherwise the monitoring data will be incorrect.
- Outer diameter of the AC cable should be smaller than the hole diameter of the CT, so that the AC cable can be routed through the CT.
- To ensure accurate current detection, the CT cable is recommended to be no more than 30m.
- Do not use network cable as the CT cable. Otherwise the smart meter may be damaged due to high current.
- CTs vary slightly in dimensions and appearance depending on the model, but they are installed and wired in the same way.

Connection Method

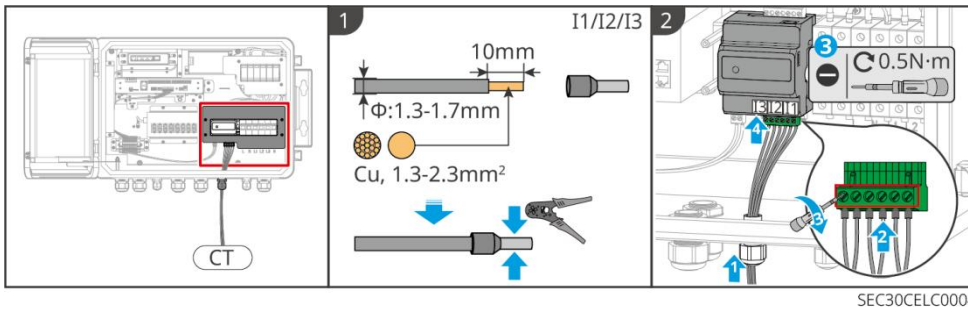

Installing the CT (Type I)

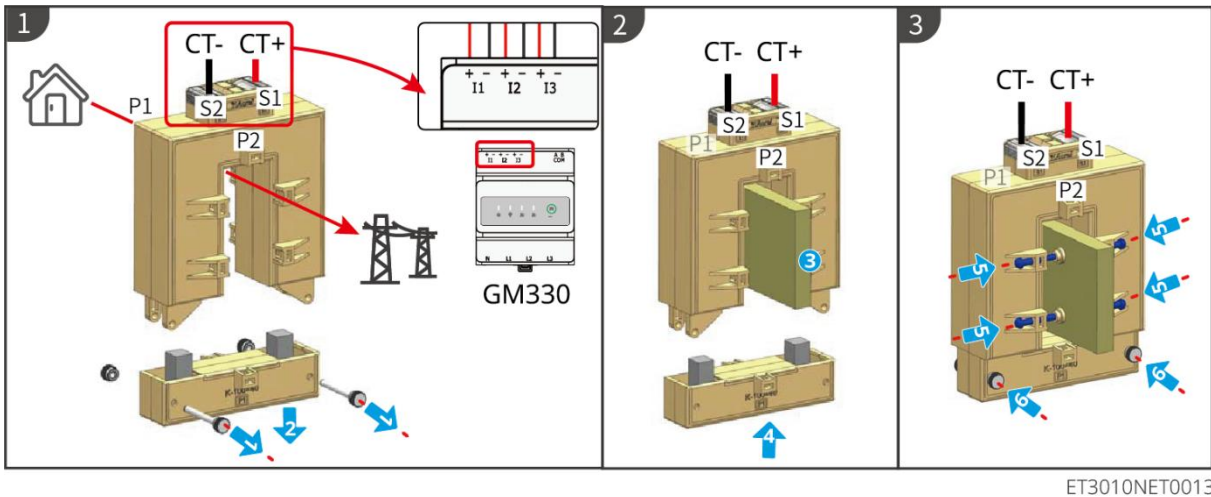

Installing the CT (Type II)

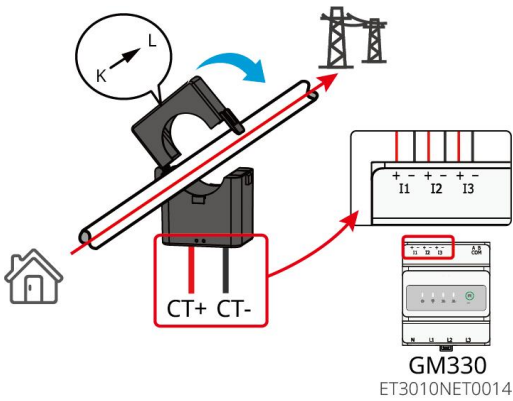

6.7 RS485 Communication Cable (Grid-tied Inverters)

NOTICE

- Supports connection to grid-tied inverters, currently supporting models: GT series inverters.
- A maximum of 20 inverters can be connected to one RS485 port.
- The smart energy control box provides 3 sets of available RS485 connection terminals. Please connect the RS485 communication cable to any one of the RS485 terminals.

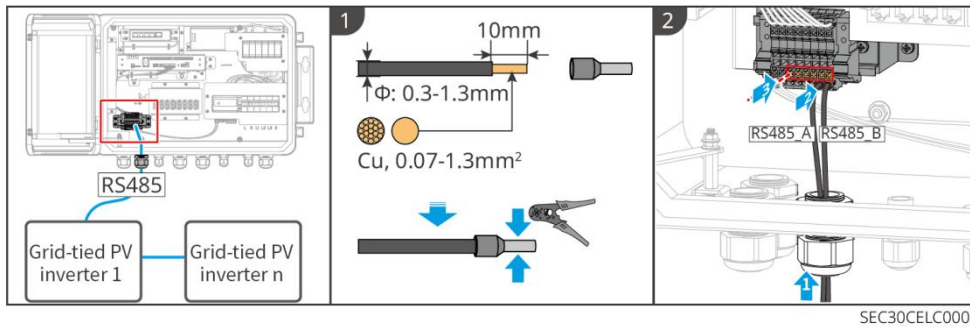

6.8 Ethernet Cable (Hybrid inverter / Computer)

NOTICE

- Support connection to hybrid inverters via the smart dongle, currently supporting models: ET40-50kW series inverters.
- Please provide your own WiFi/ LAN Kit-20 smart dongle for connecting the hybrid inverter, ensuring that the dongle version is no lower than V2.2.29.
- Supports connection to a computer. After connecting the device to the computer via Ethernet cable, you can log into the embedded web configuration system to adjust relevant parameters.
- If the computer only provides USB, Type-C, or other ports when connecting via Ethernet cable, please prepare your own Ethernet adapter.
- The smart energy control box provides 15 available network ports. Connect the Ethernet cable to any network port according to actual needs.

Hybrid inverter

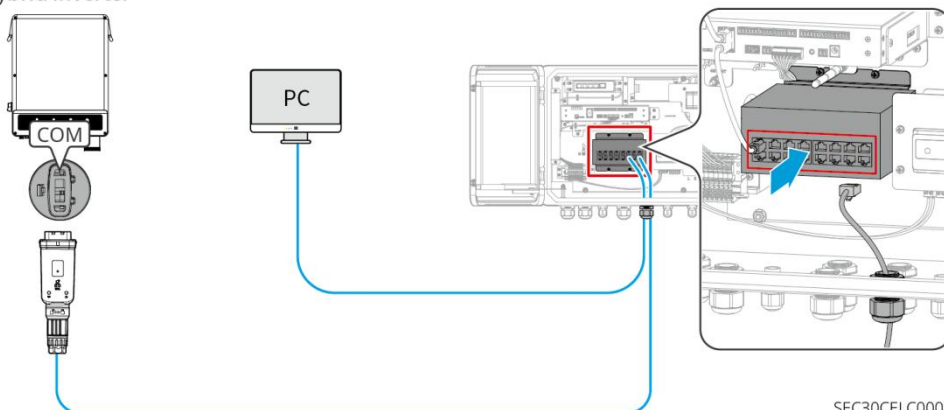

6.9 4G Antenna (Optional)

NOTICE

- If the GoodWe 4G router is selected, it will be installed before shipment.
- Routers from other manufacturers are also supported. If selected, the 4G router needs to

be installed manually.

- If you need to install a 4G antenna extension cable, do not place the extension cable crossed with other communication cables, as this may affect the signal.
- The SIM card needs to be prepared by the client. Recommended SIM card (size: 25 mm × 15 mm, capacity \geq 64 KB). When connecting a single inverter, the data plan should be at least 5MB per day. For N inverters, the data plan should be at least $5 \times N$ MB per day.

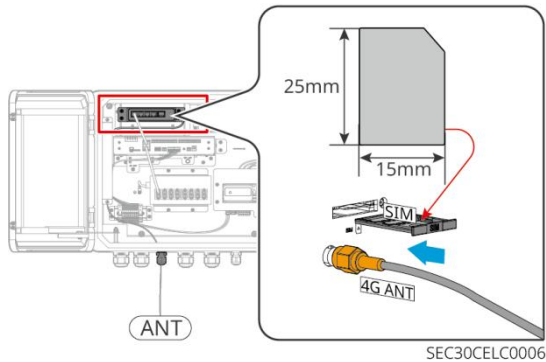

6.10 DO/DI/AI/PT Cable

NOTICE

- SEC has a in-built data logger. To enable functions such as RCR, remote shutdown or to connect an external equipment such as a temperature sensor, connect the corresponding cables.
- The smart energy control box has reserved DI/DO/AI/PT cable entry holes. If you need to connect the corresponding cables, route them through the reserved entry holes.
- If using a self-provided 4G router, connect it to the 24V DC output port of the data logger to supply power to the router.
- For corresponding cable and specific connection steps, refer to [EzLogger3000C User Manual](#).

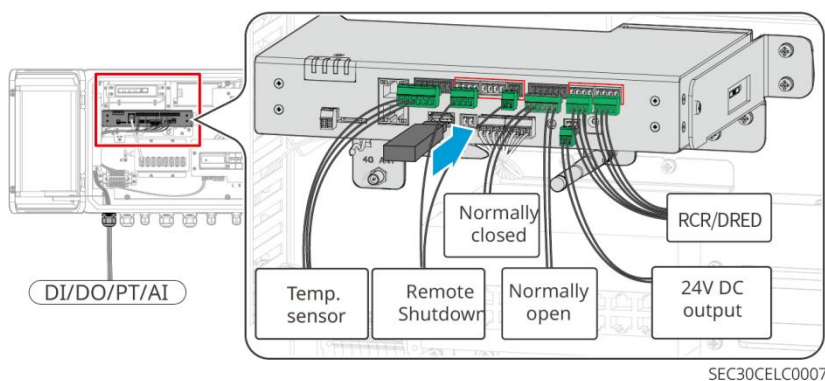

7 System Commissioning

7.1 Check before Power ON

No.	Port definition
1	The equipment is firmly installed in a clean place where is well-ventilated and easy to operate.
2	The PE cable, AC output cable, and communication cable are connected correctly and securely.
3	Cable ties are intact, routed properly and evenly.
4	Unused wire holes are sealed with waterproof covers.
5	Make sure the used cable holes are sealed properly.

7.2 System Power ON

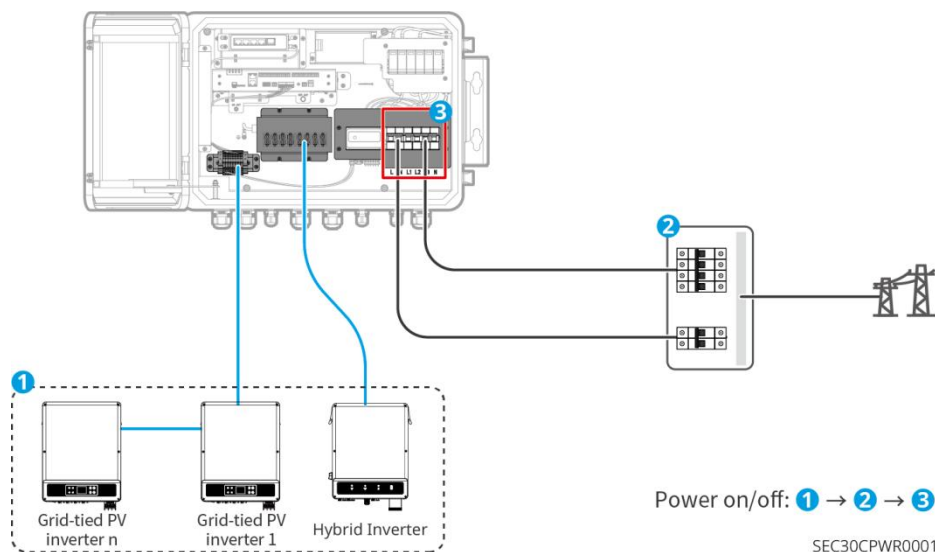









7.3 Indicator





Check the LED of the in-built data logger and smart meter of SEC3000C.

EzLogger

Indicator	Status	Description
PWR		Steady green: The device is powered on.
		Green off: The device power supply is abnormal.

RUN		Steady green/Green off: The device fails to work.
		
NET		Steady green: Communication between the device and the server is normal.
		Fast blinking green: Communication between the device and the router is normal, but communication between the device and the server fails.
		Slow blinking green: Communication between the device and the router fails.
ALM		Steady red: All the connected inverters are in fault status.
		Fast blinking red: the equipment is being upgraded.
		Red off: At least one inverter in the system is working properly.

Smart meter

Type	Status	Description
Power indicator light 	On	The smart meter is powered on. No RS485 communication.
	Blink	The smart meter is powered on. Normal RS485 communication.
	Off	The smart meter is powered off.
Communication light 	Off	Reserved
	Blink	Press the Reset button for at least 5 seconds, power light, purchasing or selling electricity indicator light flash: reset the meter.
Purchasing or selling electricity indicator light 	On	Import from the grid.
	Blink	Export to the grid.
	Off	No purchasing or selling.
	Reserved	

7.4 Close the Cabinet Door

Install plate in wiring area and close the cabinet door

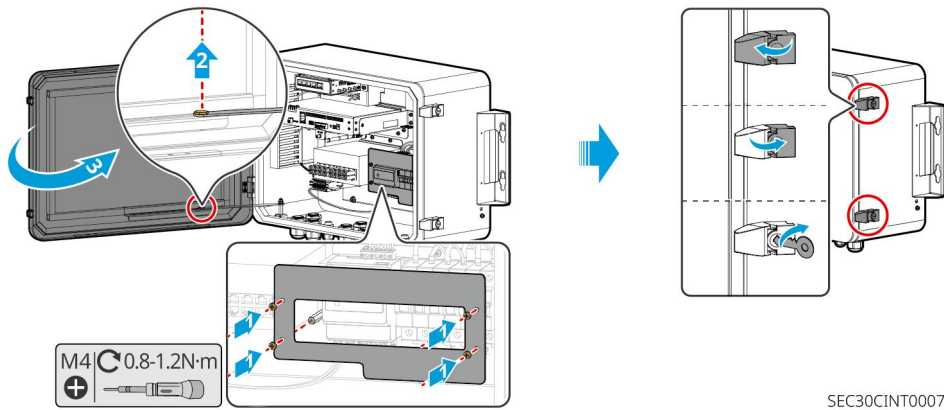

8 System Commissioning

8.1 Log into the WEB

NOTICE

- All the equipment in the system are installed properly and powered on.
- Before login, ensure that the equipment meets the following requirements:
 - Supports Windows 7 or above version.
 - Browser: Chrome 52, Firefox 58, or later version is recommended.
 - The computer's network port is connected to switch's network port with a network cable.
- Remove the network cable after configuration.
- If the system includes ET40-50kW serieshybrid inverters, prior to logging into the WEB interface, use the SolarGo App to connect all ET inverters individually and enable the Modbus-TCP function. Otherwise, communication between the ET40-50kW series inverters and the controller will fail. For more details, click the [SolarGo App User Manual](#) or scan the QR code below to view the manual.



SolarGo App User Manual

Log into the web using the default IP

Step 1 Connect a PC to any network port of the controller switch with a network cable.

Step 2 Select **Network and Internet > Change Adapter** on your computer system. In the

network connections dialogue box that appears, right-click and select **Properties** to configure the IP address of the computer and the device on the same network segment.

No.	IP Parameter	Default Value	Example value of the Computer
1	IP address	172.18.0.12	172.18.0.22
2	Subnet Mask	255.255.255.0	255.255.255.0
3	Default Gateway	172.18.0.1	172.18.0.1

Step 3 Enter <http://172.18.0.12> or <https://172.18.0.12:443> in the address bar of the web browser and press Enter.

Step 4 Select the language according to the actual demanding. Log in with the initial account and password. Initial account: admin; password:123456.

Log into the web using the dynamic IP address.

Step 1 Connect the PC and the controller to a router at the same time.

Step 2 Check the IP address assigned to the controller on the router management page.

Step 3 Enter distributed IP in the address bar of the web browser and log in.

Step 4 Select the language according to the actual demand. Log in with the initial account and password. Initial account: admin; password:123456.

Log into the web with WiFi.

Step 1 Connect to the default WiFi name of the EzLogger. Default WiFi: Log-***,*** means serial number of the EzLogger. Initial password: 12345678.

Step 2 Enter <http://172.18.0.12> or <https://172.18.0.12:443> in the address bar of the web browser and press Enter.

Step 3 Select the language according to the actual demand. Log in with the initial account and password. Initial account: admin; password:123456.

NOTICE

Use the initial password to log in. Change the password as soon as possible and keep it in mind. To ensure the security of the account, it is recommended to change the password regularly.



8.2 Configure the Start Guide

Step 1 After logging into the web, you will enter into the **Start Guide**. Select the type of devices to be connected based on the actual situation, and once selected, you will enter the web commissioning interface.

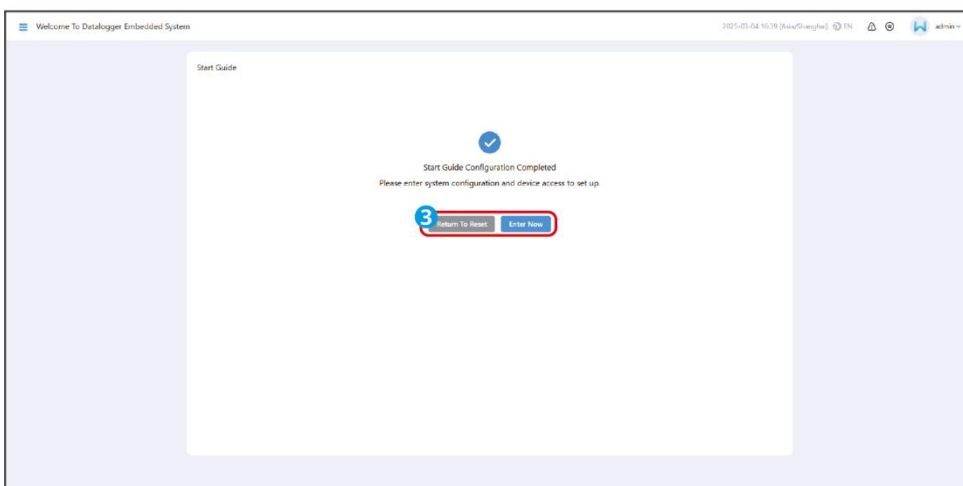
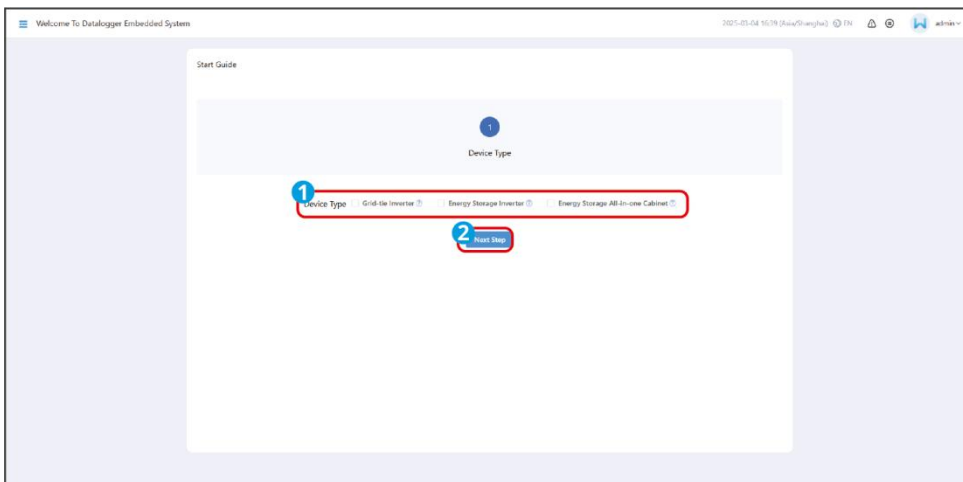

8.3 Configure the System Networking

Step 1 Go to **Device Maintenance > Network Settings > Ethernet Network** to access the device

networking interface. The hybrid inverters are connected to ETH2 port of the data collector via a switch. Set the **Port Selection** based on the actually linked port. Click **Start Searching** to start searching for online hybrid inverters.

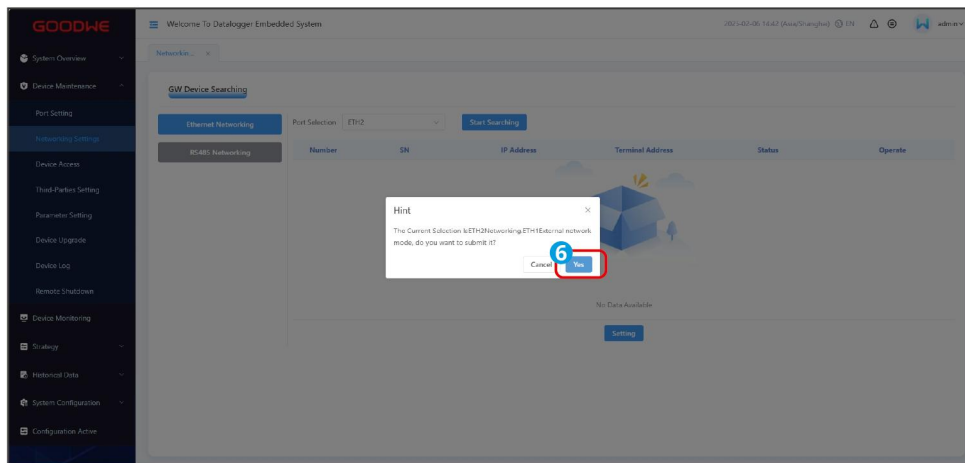
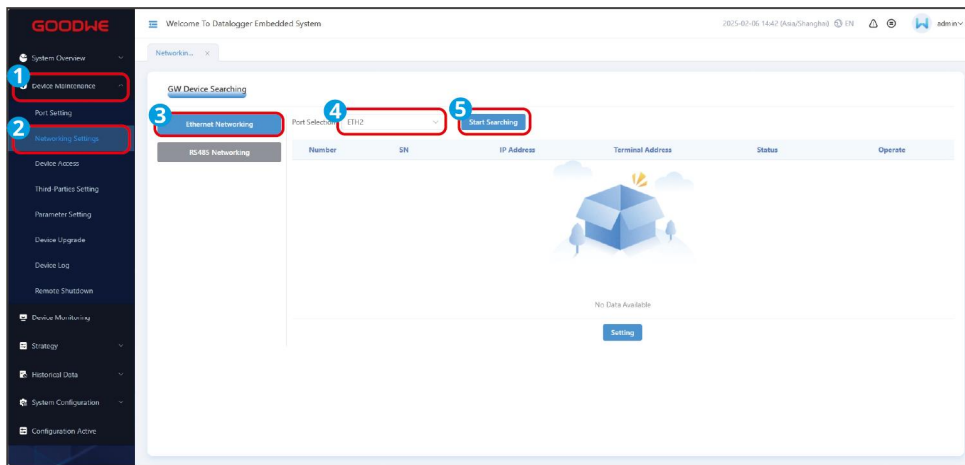

Step 2 In the device search interface, check the number of devices found. When the number of inverters matches the actual number, click **Stop Searching** to end the search.

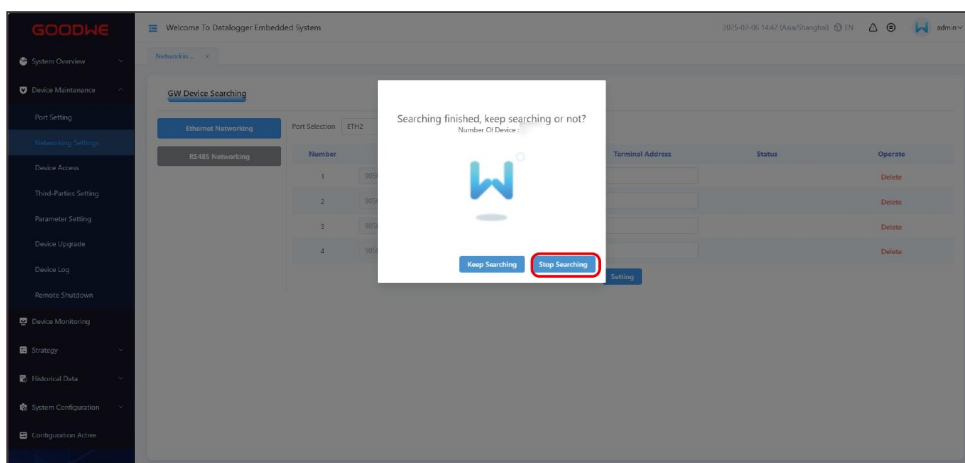

Step 3 After the search completes, return to the device networking interface, and set the terminal address of the inverter according to real needs. The terminal address range is 1-125. If there are multiple inverters, ensure that the terminal addresses are not duplicated. Click **Setting** to complete the Ethernet networking setup.

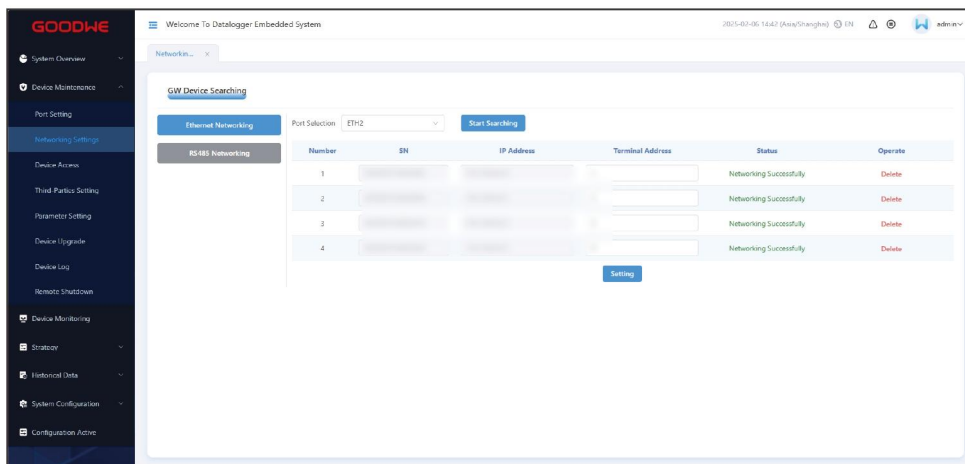
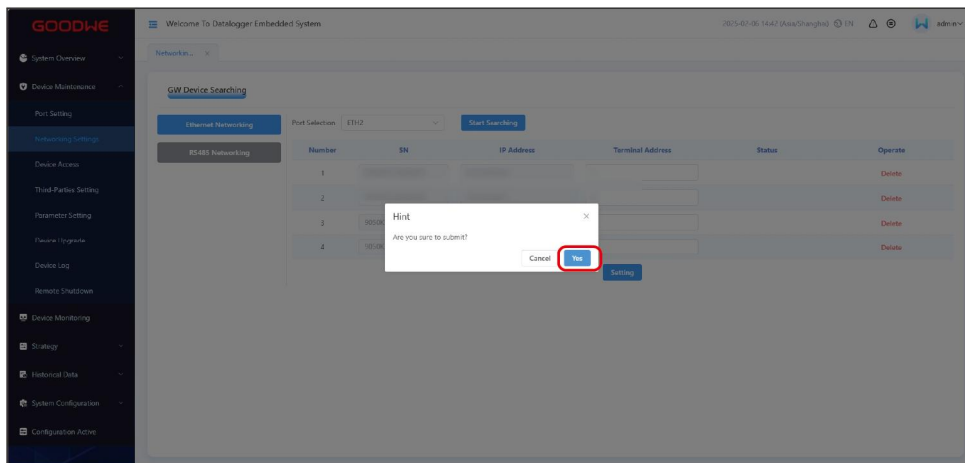
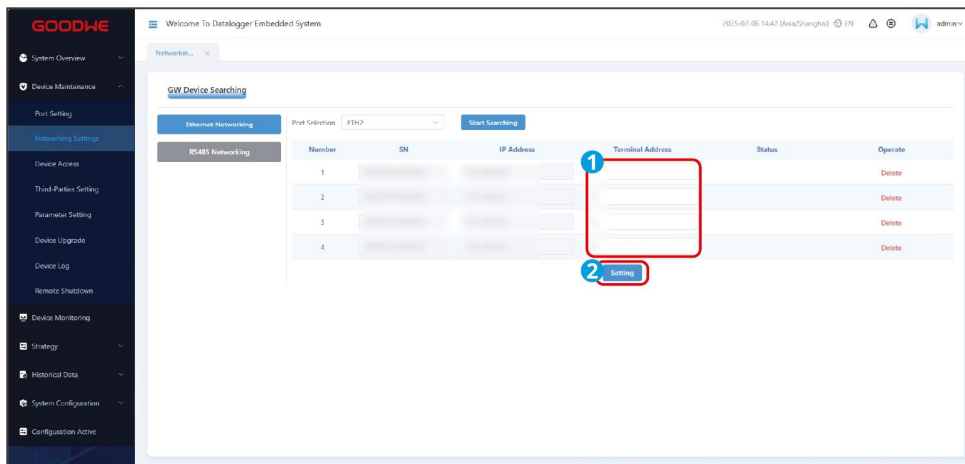

Step 4 Go to **Device Maintenance > Networking Settings > RS485 Networking** to access the device networking interface. Click **Start Searching** to begin searching for online grid-connected inverters and meters.

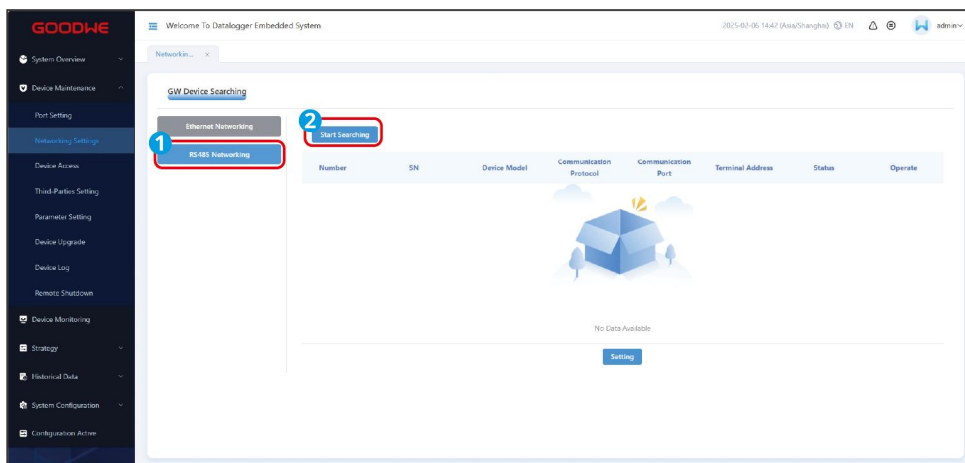

Step 5 In the device search interface, check the number of devices currently found. The displayed device count is the sum of the inverters and meters. When the number of devices found matches the actual count, click **Stop Searching** to end the search.

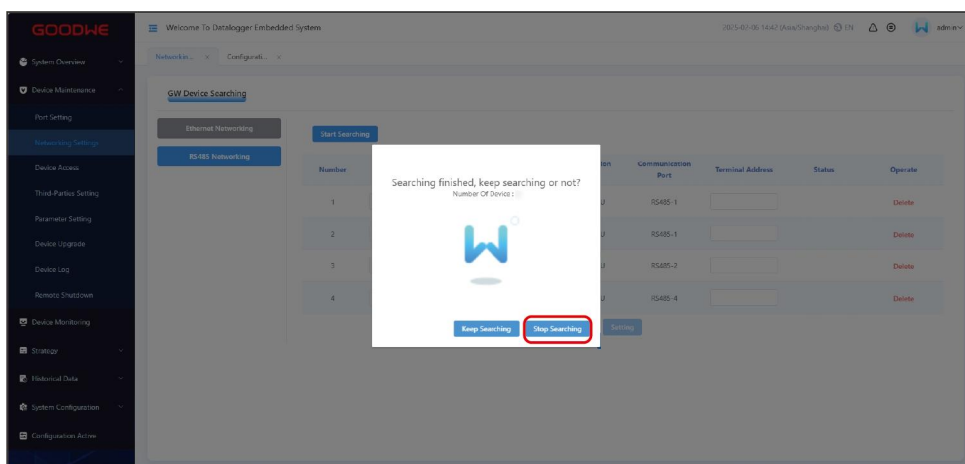

Step 6 After the device search completes, return to the device networking interface. Set the terminal addresses for the inverters and meters based on actual requirements. The terminal address range is 1-247 for inverters and 1-125 for smart meters. If there are multiple inverters and meters, ensure that the terminal addresses are not duplicated. Click **Setting** to complete the RS485 networking setup.

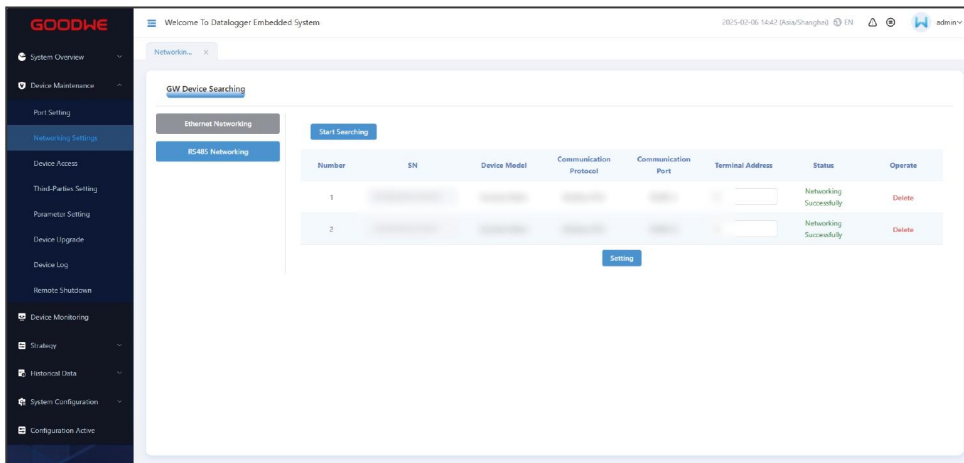
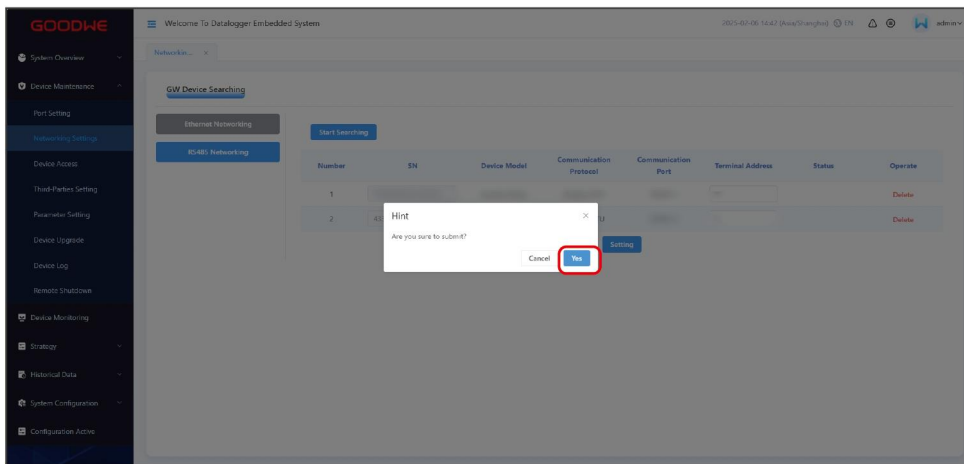
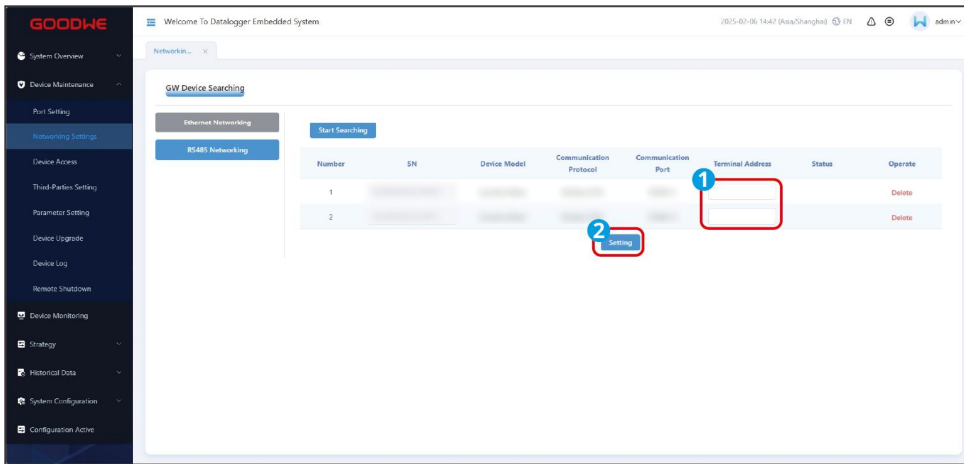

Step 7 Finish networking configuration by clicking **Configuration Active**.

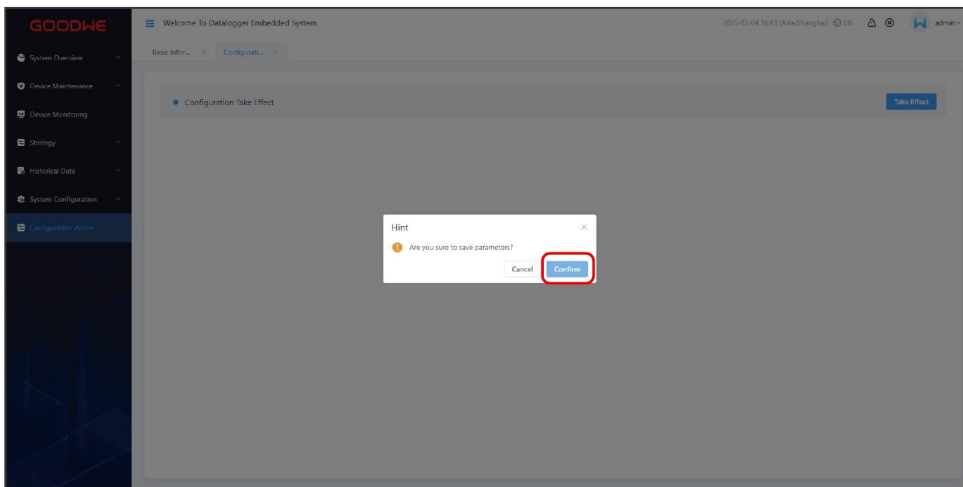
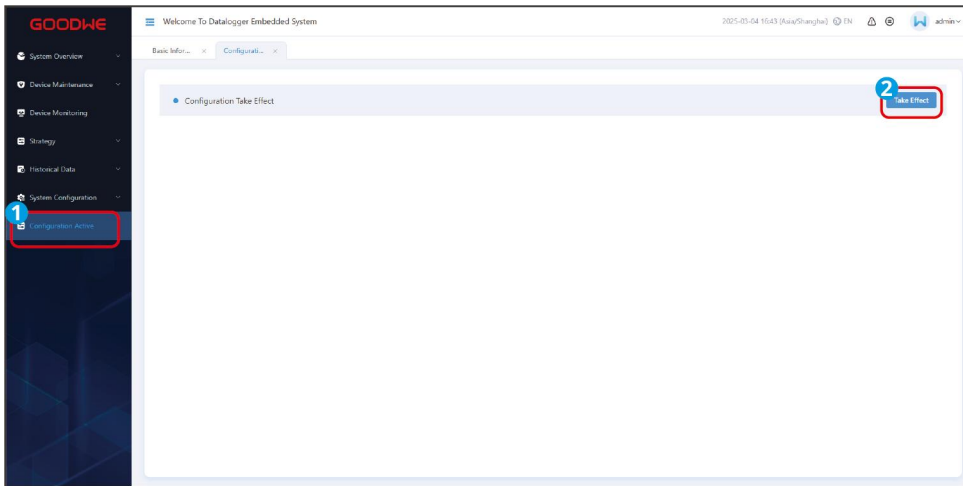

8.4 Set Meter Parameters

Step 1 Go to **Device Maintenance > Parameter Setting > Meter** to set the parameters.

Step 2 Select the meter that you want to view or configure.

Step 3 Check the parameters that you want to view or set, and click **Search** to check the current values of the selected connection parameters. To modify, input the **Modification Value** and click **Setting** to apply the changes.

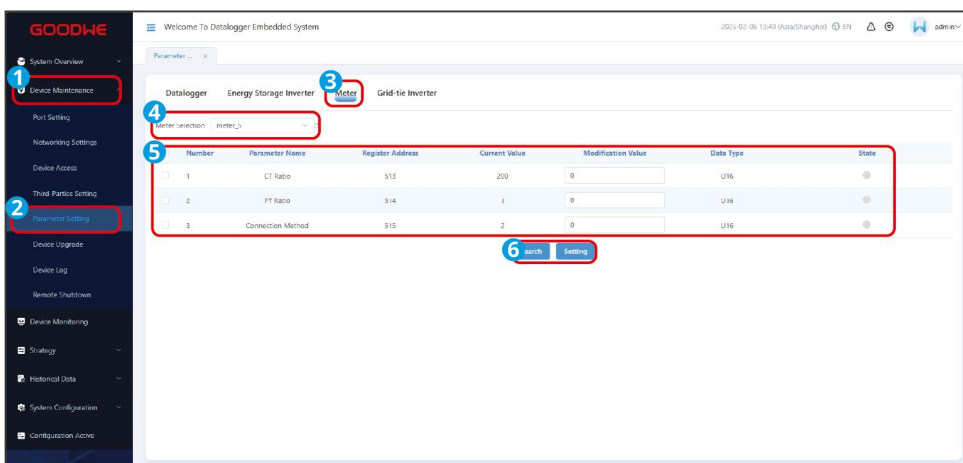

No.	Parameter	Description
1	CT Ratio	Set the ratio of the primary current to the secondary current of the CT.
2	PT Ratio	Set the ratio of the primary voltage to the secondary voltage of the PT.
3	Connection Method	Set the connection method of the meter according to the real situation.

9 System Commissioning

9.1 Introduction to Web UI

Log into the embedded web to set parameters of the device, check running information and alarms to get the system status information in time.

 **WARNING**

- The WEB firmware version shown in this document is V4.0.21.35. The screenshots are for reference only. The actual display may differ.
- The name, range, and default value of the parameters are subject to change. The actual display prevails.
- When issuing reset, shutdown and upgrade commands to the inverter, the inverter may fail to connect to the utility grid, which will affect the power generation.
- The grid parameters, protection parameters, characteristic parameters, and power regulation parameters of the grid-connected inverter, as well as the frequency parameters, connection parameters, protection parameters, and other safety regulation parameters of the hybrid inverter, shall be set by professionals. Improper settings may cause the inverter's failure to connect to the grid, thus affecting the power generation.

9.1.1 WEB Layout

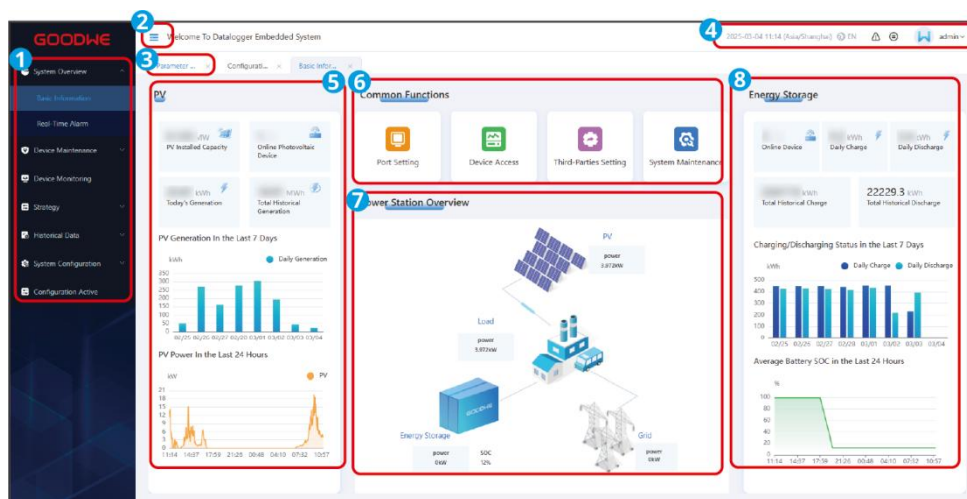

No.	Function	Description
1	Menu list	Menu on the Interface. Choose the main menu, then the second-level menu will be displayed. Under some main menus, there are no second-level menu.
2	Menu list button	Click to hide or show the menu list.

3	Tag list	Displays the opened menu tags.
4	System status	<ul style="list-style-type: none"> ● Displays the system time. ● Switches the system language. ● Displays the alarming information. Click it to check the real-time alarms. ● Displays the version of the product. ● Displays the log in status. Click it to log out.
5	PV	<p>Displays information about PV power generation.</p> <ul style="list-style-type: none"> ● PV Installed capacity: it refers to the total rated capacity of all inverters in the system and needs to be manually set. ● Online Photovoltaic Device: the number of hybrid inverters that are currently online ● Today's Generation: the overall power generation of all inverters on the PV side on this day. ● Total Historical Generation: the overall power generation previously of all inverters on the PV side. ● PV Power generation in the last 7 days: histogram for power generation per day in the last 7 days. ● PV Power in the Last 24 Hours: power generation capacity curve in the last 24 hours displayed by hour.
6	Common Functions	Displays commonly used functions and can be directed to corresponding setting page.
7	Power Station Overview	Current energy balance sheet and power information of the current power plant.
8	Energy Storage	<p>Displays energy storage information about the current system.</p> <ul style="list-style-type: none"> ● Online Photovoltaic Device: the number of hybrid inverters that are currently online. ● Daily Charge: The charging power of the battery for the current day. If there is cyclical charging, the cumulative charging power is displayed. ● Daily Discharge: The discharging power of the battery for the current day. If there is cyclical charging, the cumulative discharging power is displayed. ● Total Historical Charge: the cumulative charging power of the battery. ● Total Historical Discharge: the cumulative discharging power of the battery. ● Charging / Discharging Status in the Last 7 Days: a bar chart displaying the daily charging or discharging power for the last 7 days. ● Average Battery SOC in the Last 24 hours: display SOC changes of



the battery in the last 24 hours by hour.

9.1.2 WEB Menu on the Interface

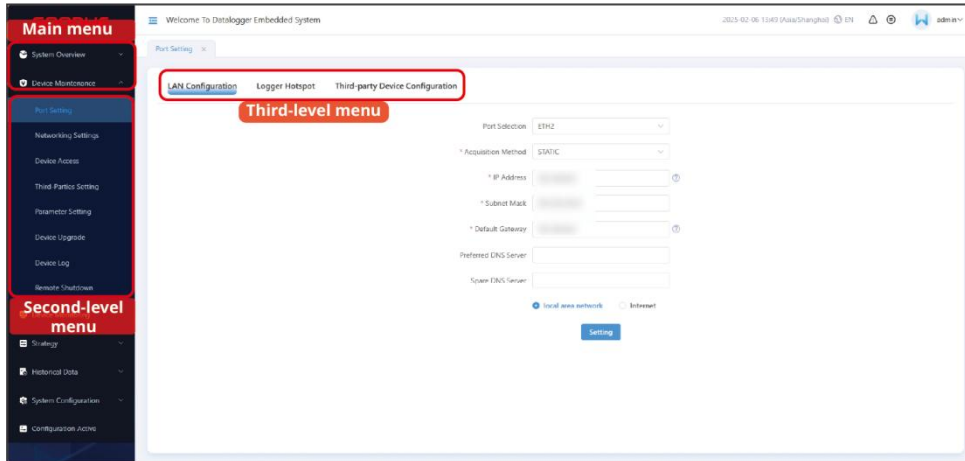

Main menu	Second-level menu	Third-level menu	Description
System Overview	Basic Information	-	<ul style="list-style-type: none"> Displays information including PV power generation, installed capacity of the system. Set common functions such as Port Setting, Device Access, Third-party Setting, System Maintenance. Displays energy flow chart of the power plant. Displays daily and historical charging and discharging of the hybrid inverter.
	Real-Time Alarm	-	Displays alarm name, device SN and production time. You can refresh the latest alarm list by clicking the manual refreshing button.
Device Maintenance	Port Setting	LAN Configuration	Set LAN Communication parameters.
		Wi-Fi Configuration	Set WiFi name and password of the controller.
		Third-party Device Configuration	Set RS485 Parameter. Support connection to the third party device via RS485.

	Networking Settings	-	Set the System Networking.
	Device Access	-	Add grid-tied inverters, hybrid inverters, meters and others.
	Third-Parties Setting	Modbus-TCP	Set Modbus-TCP parameters.
		Output Power Control	Set output power control parameters. Only applicable to Japan.
	Parameter Setting	Datalogger	Set log parameters and array parameters of the EzLogger.
		Hybrid inverter	<p>Set parameters of hybrid inverters.</p> <ul style="list-style-type: none"> ● Quick configuration: quick configuration of the safety countries and the battery connection mode of hybrid inverters. ● Wiring mode: only applicable to inverters of ET40-50kW series. Set the wiring mode of inverters. ● Basic parameters: Set parameters of hybrid inverters. ● Advanced settings: Set advanced parameters of hybrid inverters. ● Grid code settings: set advanced safety regulation parameters of hybrid inverters. ● Generator settings: only applicable to inverters of ET40-50kW series. Set parameters of generator connected to inverters.
		Meter	Set meter parameters, such as CT ratio, PT ratio, connection method.
		Grid-tied inverter	The grid parameters, protection parameters, characteristics parameters and power adjustment parameters of the grid-tied inverters.
		Device upgrade	EzLogger
	Inverters		Upgrade the version of inverters, including DSP, ARM, module versions.

	Device Log	-	Check device operation log, such as log in / out of the web, modify the password.
	Remote Shutdown	OVGR&RPR	Set OVGR&RPR parameters. Only applicable to Japan.
		Remote shutdown	Set remote shutdown parameters. Only applicable to Germany.
		AC fault detection	Set OVGR&RPR parameters. Only applicable to Japan.
Device monitoring	-	-	Check operation status, device SN, version, real-time data of the device in the system. It is supported to check the grid-tied inverters, hybrid inverters (including batteries), meters and other devices currently.
Strategy	Operation mode	-	Set the working mode of hybrid inverters. Currently supported: Self-use mode, Smart charging mode, Back-up mode, TOU mode, Peak shaving mode.
	Power adjustment	-	Set RCR parameter.
	Power Limit	-	Set grid-tied power limit parameters.
	Abnormal communication configuration	-	Handling measures for abnormal communication.
Historical Data	Historical fault and alarm	-	Check historical faults and alarms.
System configuration	System Maintenance	-	<ul style="list-style-type: none"> ● Reset Logger ● Restore Factory Settings ● Import All Configuration Files ● Export All Configuration Files ● Start Guide
	System Time	-	Set the clock source. Supported: NTP, IEC104,

			Modbus-TCP, Management System, Goodwe Cloud Platform Time Synchronization.
	Security Setting	-	Set security parameters, such as account and password.
	System Commissioning	-	For internal testing.
	Version	-	Check the version of the EzLogger, like SN, Main Program Version, Firmware Version, Web Version, etc.
Configuration Active	-	-	Save the set parameters. Click Configuration Active to save the settings after configuration adjustments.

9.1.2 Log into the WEB

NOTICE

- All the equipment in the system are installed properly and powered on.
- Before login, ensure that the equipment meets the following requirements:
 - Supports Windows 7 or above version.
 - Browser: Chrome 52, Firefox 58, or later version is recommended.
 - The computer's network port is connected to switch's network port with a network cable.
- Remove the network cable after configuration.
- If the system includes ET40-50kW serieshybrid inverters, prior to logging into the WEB interface, use the SolarGo App to connect all ET inverters individually and enable the Modbus-TCP function. Otherwise, communication between the ET40-50kW series inverters and the controller will fail. For more details, click the SolarGo App User Manual or scan the QR code below to view the manual.



SolarGo App User Manual

Log into the web using the default IP

Step 1 Connect the PC and the controller to a router at the same time.

Step 2 Select **Network and Internet > Change Adapter** on your computer system. In the network connections dialogue box that appears, right-click and click **Properties** to configure the IP address of the computer and the device on the same network segment.

No.	IP Parameter	Default Value	Example value of the Computer
1	IP address	172.18.0.12	172.18.0.22
2	Subnet Mask	255.255.255.0	255.255.255.0
3	Default Gateway	172.18.0.1	172.18.0.1

Step 3 Enter <http://172.18.0.12> or <https://172.18.0.12:443> in the address bar of the web browser and press Enter.

Step 4 Select the language according to the actual demand. Log in with the initial account and password. Initial account: admin; password:123456.

Log into the web using the dynamic IP address.

Step 1 Connect the PC and the controller to a router at the same time.

Step 2 Check the IP address assigned to the controller on the router management page.

Step 3 Enter distributed IP in the address bar of the web browser and log in.

Step 4 Select the language according to the actual demand. Log in with the initial account and password. Initial account: admin; password:123456.

Log into the web with WiFi.

Step 1 Connect to the default WiFi name of the EzLogger. Default WiFi: Log-***,*** means serial number of the EzLogger. Initial password: 12345678.

Step 2 Enter <http://172.18.0.12> or <https://172.18.0.12:443> in the address bar of the web browser and press Enter.

Step 3 Select the language according to the actual demand. Log in with the initial account and password. Initial account: admin; password:123456.

NOTICE

Use the initial password to log in. Change the password as soon as possible and keep it in mind. To ensure the security of the account, it is recommended to change the password regularly.

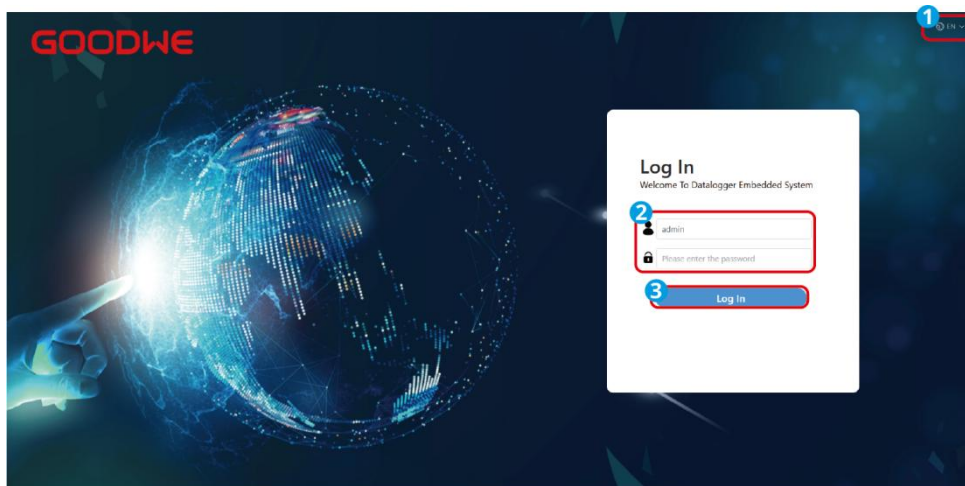

9.2 Manage the Device

9.2.1 Add Devices via Automatic Search

NOTICE

- After RS485 networking succeeds, if you need to recognize newly added inverters, click **Re-networking** to start searching, then the Ezlogger will restart. Restart inverters immediately or wait 15 minutes until click **Start Searching** once again to start researching devices in the network.
- After networking setting succeeds, if you need to add a device that is not found, click **Device Access** to add the device.

Step 1 Go to **Device Maintenance >Networking Settings >Ethernet Networking** to access the device networking interface. The hybrid inverters are connected to ETH2 port of the data collector via a switch. Set the **Port Selection** based on the actually linked port. Click **Start Searching** to start searching for online hybrid inverters.

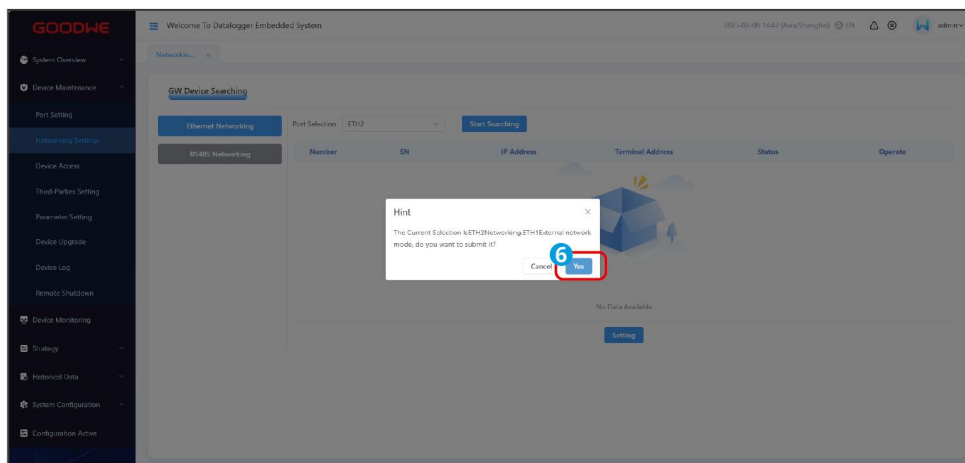
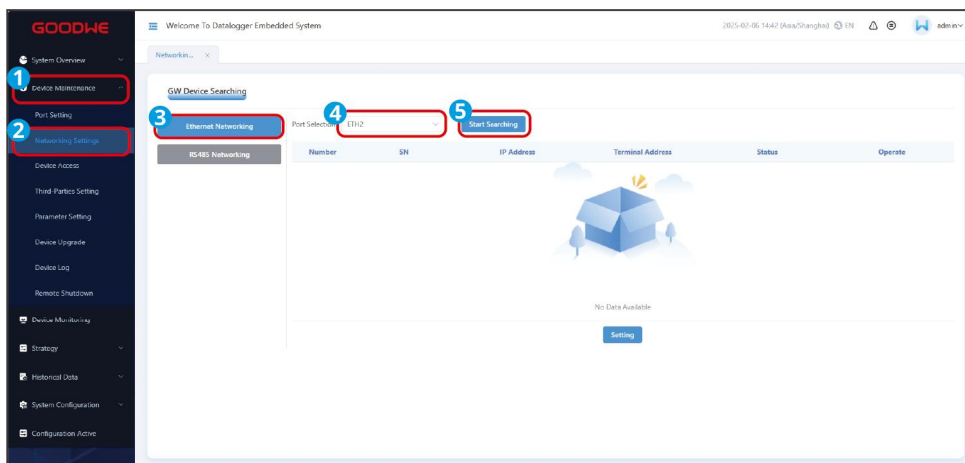

Step 2 In the device search interface, check the number of devices found. When the number of inverters matches the actual number, click **Stop Searching** to end the search.

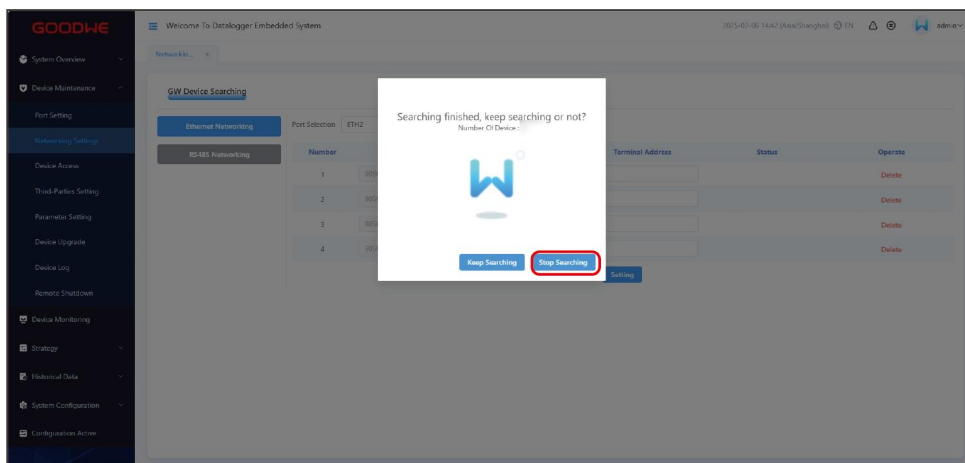

Step 3 After the search completes, return to the device networking interface, and set the terminal address of the inverter according to real needs. The terminal address range is 1-125. If there are multiple inverters, ensure that the terminal addresses are not duplicated. Click **Setting** to complete the Ethernet networking setup.

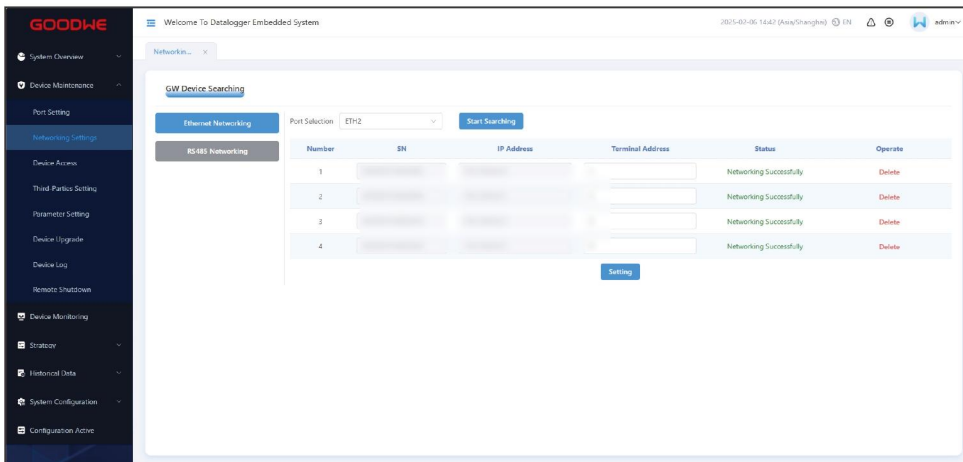
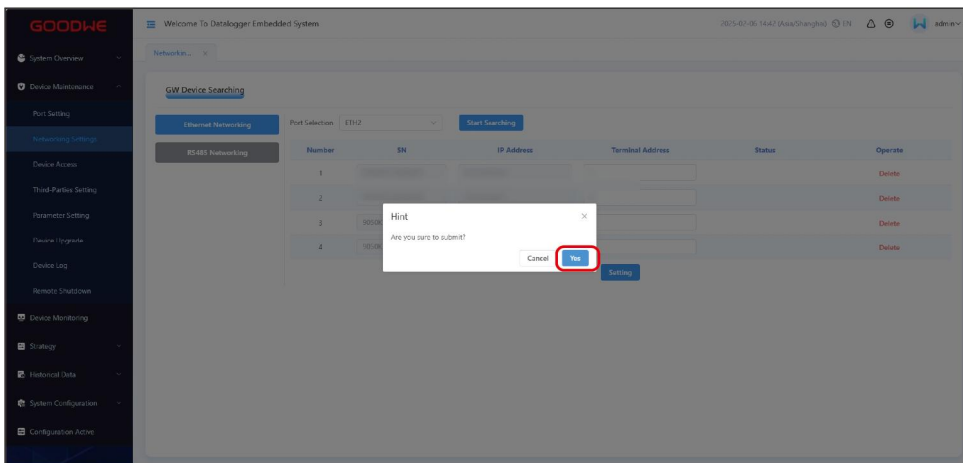
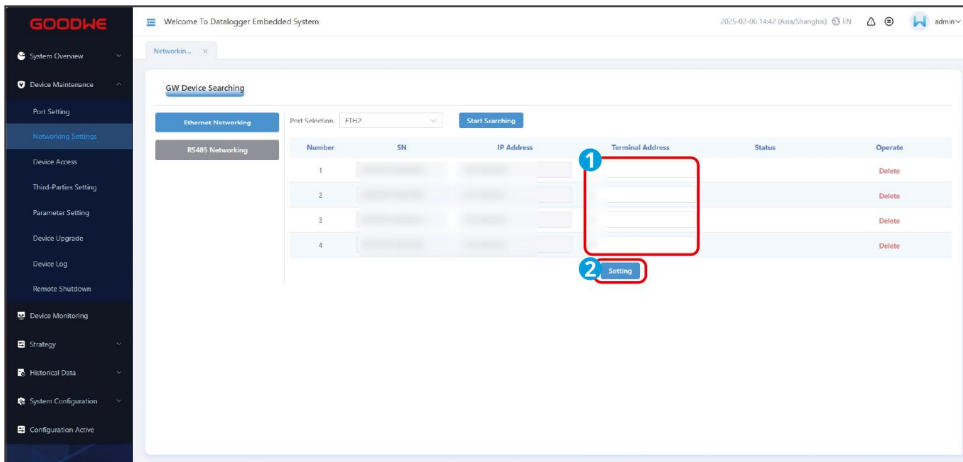

Step 4 Go to **Device Maintenance >Networking Settings >RS485 Network** to access the device networking interface. Click **Start Searching** to begin searching for online grid-tied PV inverters and meters.

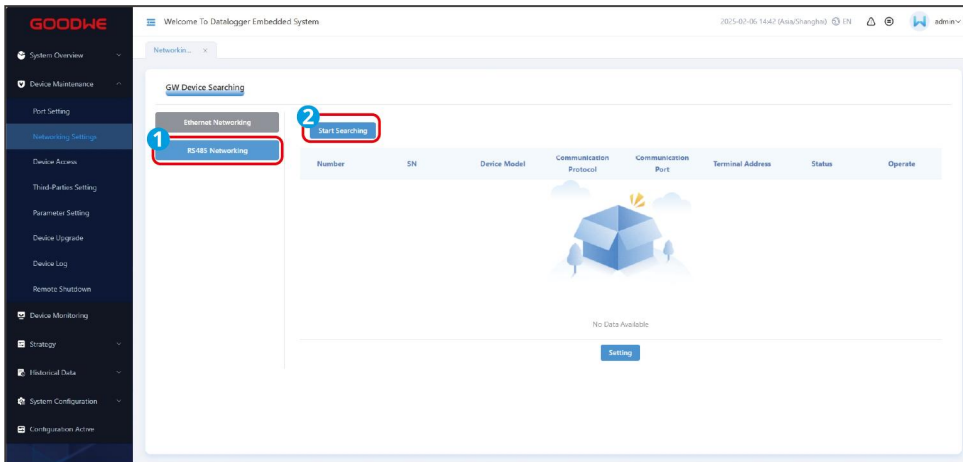

Step 5 In the device search interface, check the number of devices found. When the sum of inverters and meters matches the actual number, click **Stop Searching** to end the search.

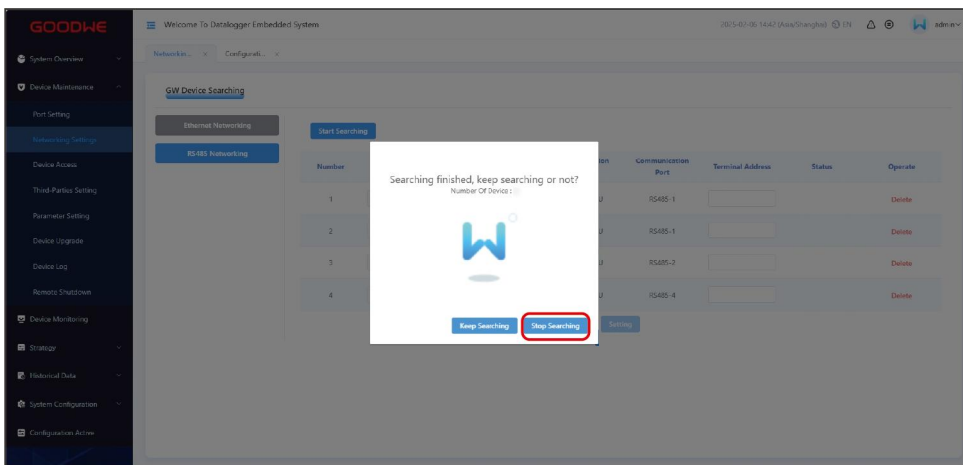

Step 6 After the device search completes, return to the device networking interface. Set the terminal addresses for the inverters and meters based on actual requirements. The terminal address range is 1-247 for inverters and 1-125 for smart meters. If there are multiple inverters, ensure that the terminal addresses are not duplicated. Click **Setting** to complete the RS485 networking setup.

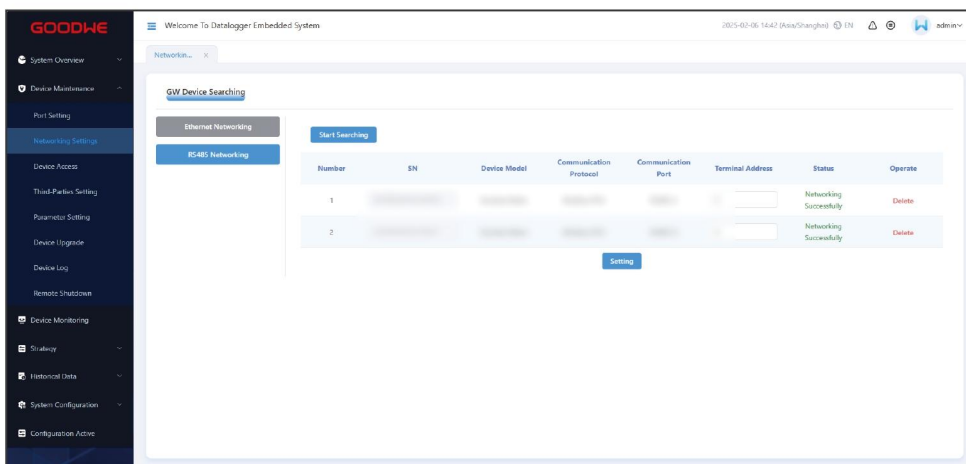
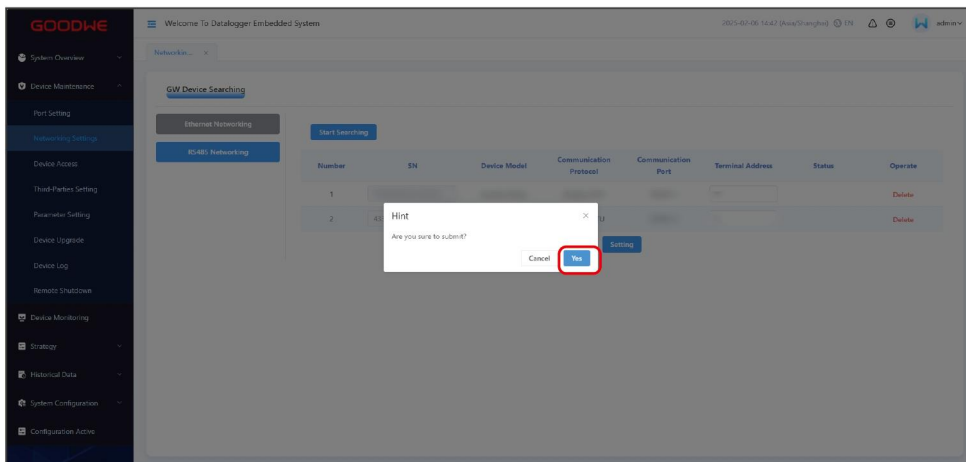
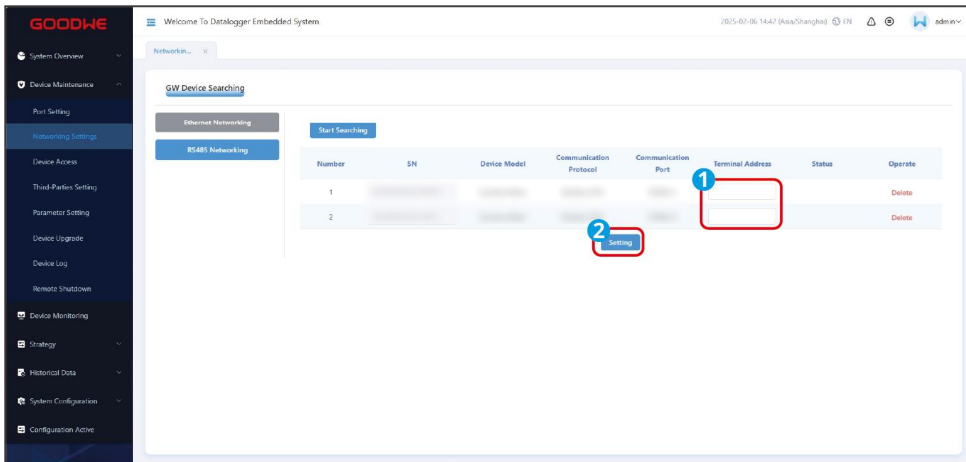

Step 7 Click **Configuration Active** to finish Networking Settings.

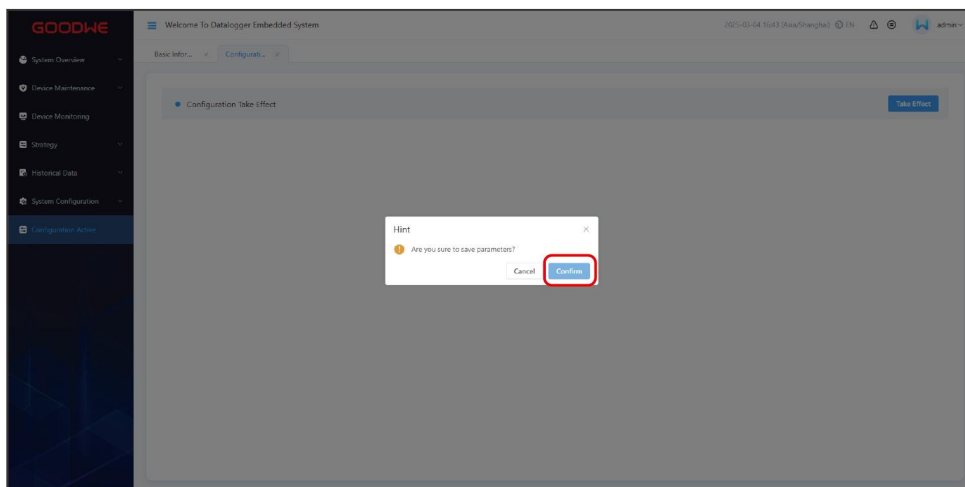
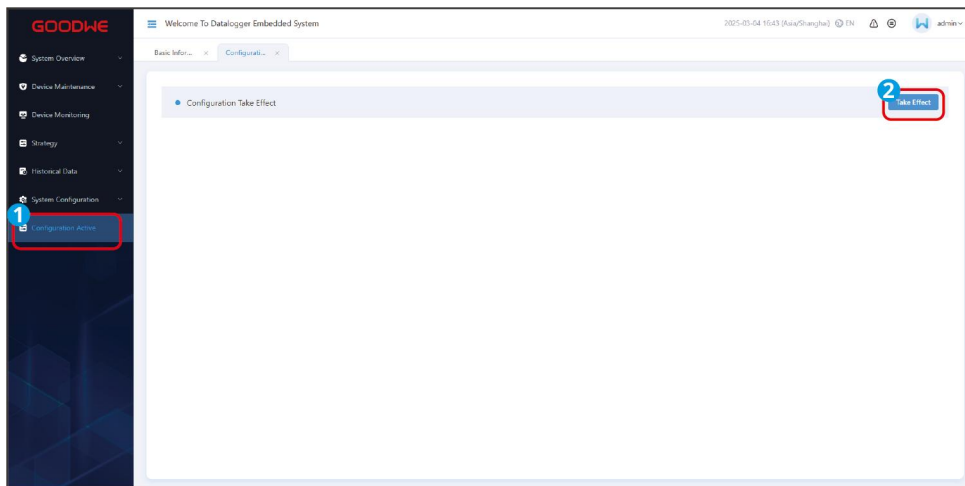

9.2.2 Add Devices Manually

NOTICE

- After networking setting succeeds, if you need to add a device that is not found, click **Device Access** to add the device.
- Click **Edit** or **Delete** to edit or delete device parameters of added devices.

Add a grid-tied inverter

Step 1 Enter into the device via **Device Maintenance >Device Access >Grid-tie Inverter >Add Device**.

Step 2 Set the device parameters based on actual needs. Click **Yes** to add the device.

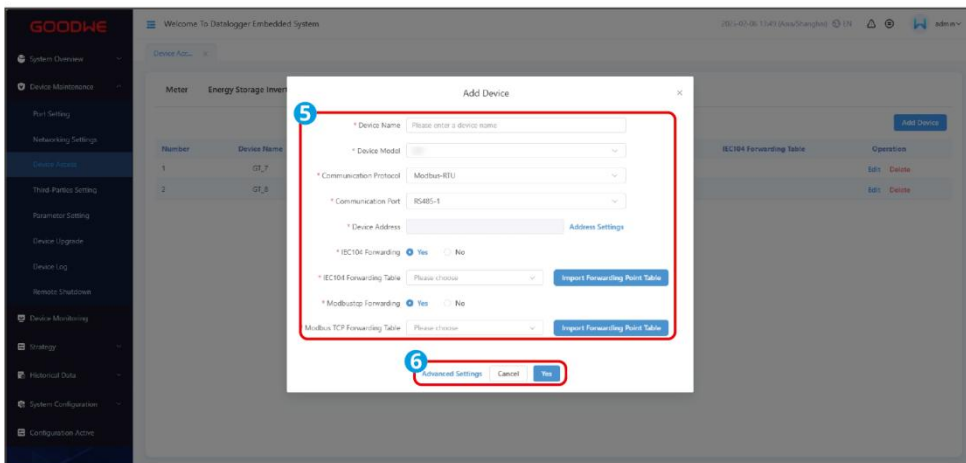
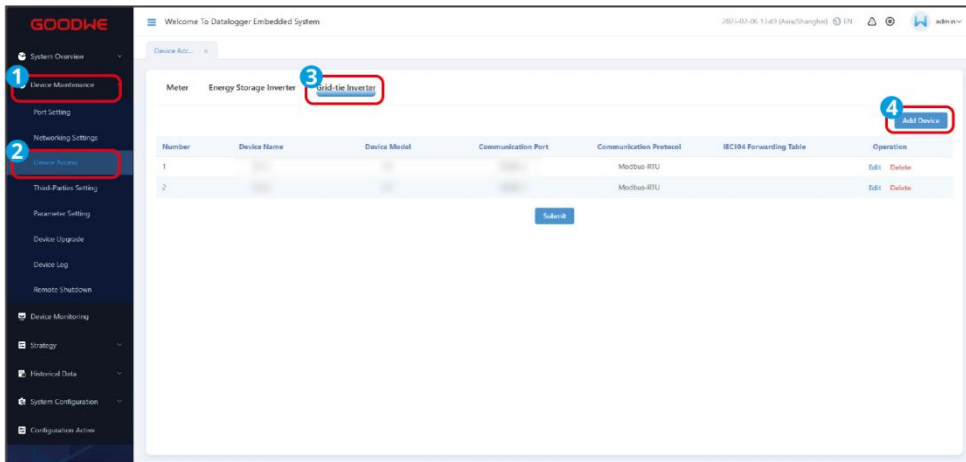

No.	Parameter	Description
1	Device Name	Define the device name based on actual needs.
2	Device Model	Select the model of the inverter that is connected to.
3	Communication Protocol	Select based on the communication protocol of the device. Currently supported: Modbus-RTU.
4	Communication Port	Select the actual connected port on the EzLogger.
5	Device Address	<ul style="list-style-type: none"> Set the terminal address of inverters based on the actual power plant planning. Select Auto-Generate when there is no need to set the parameters based on the actual settings. Make sure that the terminal addresses of different devices are different.

Add a hybrid inverter

Step 1 Enter into the device via **Device Maintenance > Device Access > Energy Storage Inverter > Add Device**.

Step 2 Set the device parameters based on actual needs. Click **Yes** to add the device.

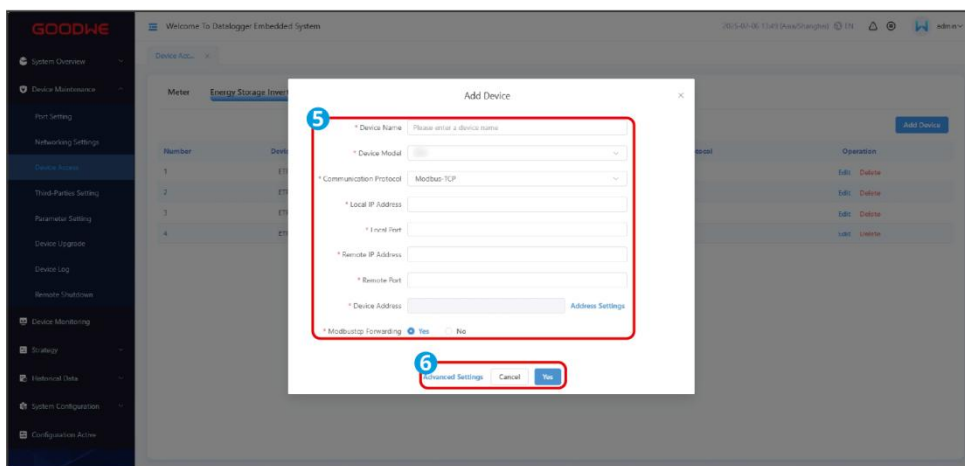
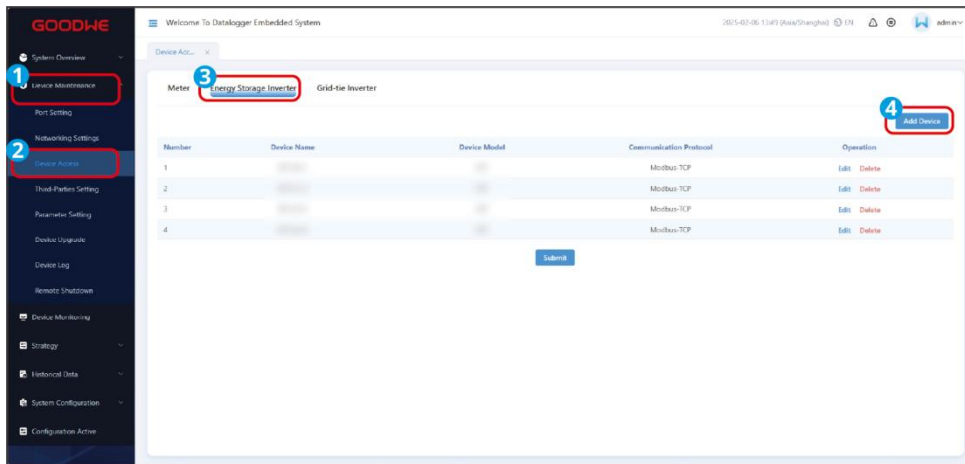

No.	Parameter	Description
1	Device Name	Define the device name based on actual needs.
2	Device Model	Select the model of the inverter that is connected to.
3	Communication Protocol	Select based on the communication protocol of the device. Currently supported: Modbus-TCP.
4	Local IP address	Set the corresponding IP address of the network port of other added devices.
5	Local Port	Set the port number of the controller. Default port number: 0.
6	Remote IP Address	Set the IP address of the WiFi / LAN Kit-20 connected to the hybrid inverter.
7	Remote Port	Set the port number of other connected devices. Default port number: 502.

8	Device Address	Set the terminal address of inverters based on the actual power plant planning. Select Auto-Generate when there is no need to set the parameters based on the actual settings.
---	----------------	---------------------------------------------------------------------------------------------------------------------------------------------------------------------------------------

Add a meter

Step 1 Enter into the device via **Device Maintenance > Device Access > Meter > Add Device**.

Step 2 Set the device parameters based on actual needs. Click **Setting** to add the device.

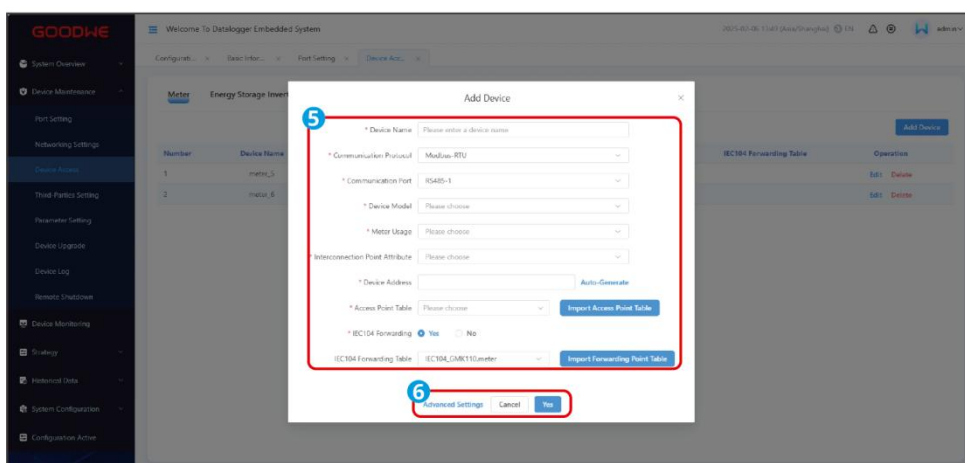
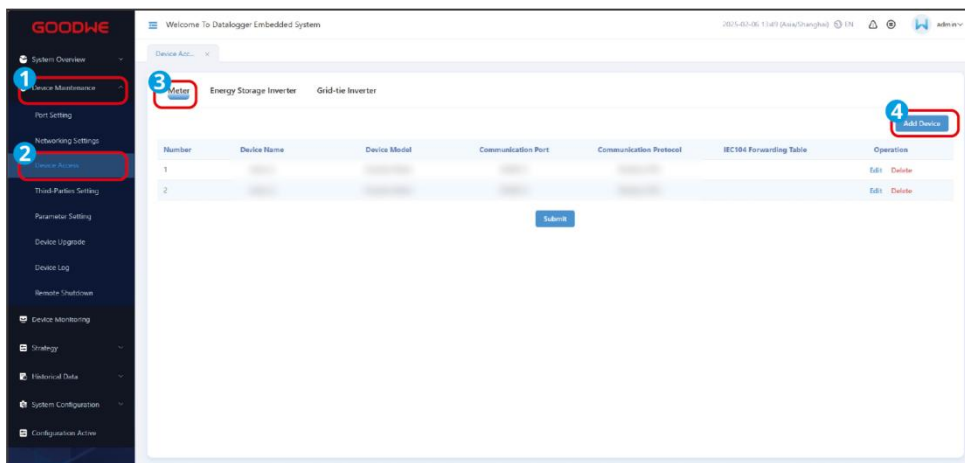

No.	Parameter	Description
1	Device Name	Define the device name based on actual needs.
2	Communication Protocol	Select based on the communication protocol of the smart meter. Currently supported: Modbus-RTU.
3	Communication Port	Select the actual connected port on the EzLogger. Supported port: RS485-1, RS485-2, RS485-3, RS485-4.
4	Device Model	Set this parameter based on the actual meter model. Supported: Goodwe Meter(GM330), UMG604PRO, Acrel-DTSD1352, Schneider-IEM3255, and Others.

5	Meter usage	<p>Select based on the actual usage.</p> <ul style="list-style-type: none"> ● Grid Side Meter: the meter's CT is installed on the grid-connection point for power limiting. ● Power generation side PV energy storage meter: the meter's CT is installed on the upper end of the grid-connected inverter and hybrid inverter, monitoring the electricity consumption data for both. ● PV meter on the power generation side: the meter's CT is installed on the grid-connected inverter side, monitoring the generation data of the grid-connected inverter. ● Power generation side energy storage meter: the meter's CT is installed on the hybrid inverter side, monitoring the generation data of the hybrid inverter.
6	Grid Connection Point Attribute	Choose based on the transformer number to which the inverter is connected.
7	Terminal Address	<ul style="list-style-type: none"> ● Set the terminal address of smart meters based on the actual power plant planning. Select Auto-Generate when there is no need to set the parameters based on the actual settings. ● Do not set the address of smart meters same as that of inverters.
8	Access Point Table	Import the access point table of the connected device.

9.3 Set Port Parameters

9.3.1 Set LAN Parameters

NOTICE

- Before configuring the LAN parameters, ensure that the network cable is correctly connected to the controller.
- After the system network configuration completes, the ETH1 and ETH2 ports will automatically complete the LAN configuration, no additional configuration is required. At this point, the ETH1 port defaults to DHCP status, and the ETH2 port defaults to STATIC status.
- The switch is by default connected to the data collector's ETH2 port, and setting the ETH2



port parameters will configure the switch's network port settings.

Step 1 Go to **Device Maintenance > Port Setting > LAN Configuration** to set the parameters.

Step 2 Set the ETH parameters based on actual needs.

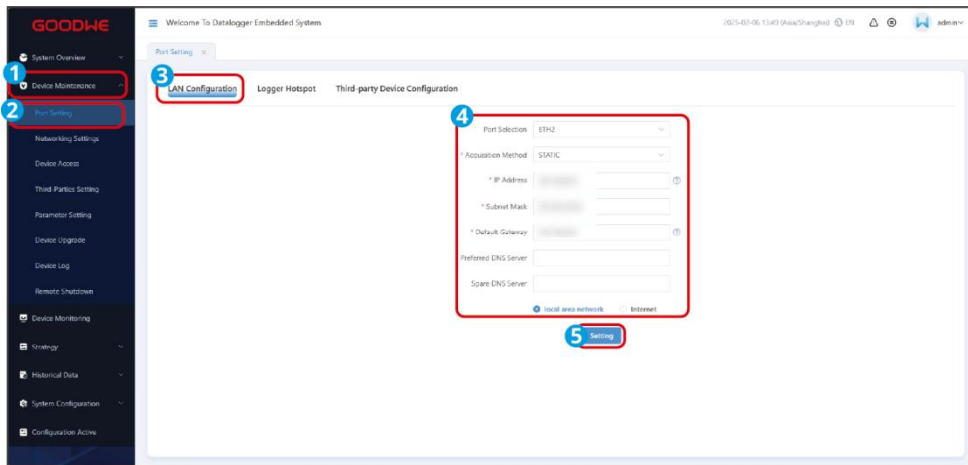

No.	Parameter	Description
1	Port Selection	Select the connected network port of the EzLogger. Supported: ETH1 or ETH2.
2	Acquisition Method	<ul style="list-style-type: none"> Manually set the fixed network parameters based on actual situation when selecting STATIC mode. The IP address can be obtained automatically when selecting DHCP mode.
3	IP address	Set the IP address of the controller. Set the IP address on the same network segment as the router IP address, and based on the power plant planning. If the IP address is modified, log in with the new IP address.
4	Subnet Mask	Set the subnet mask of the controller. Set the parameter based on the actual subnet mask of the router connected to the EzLogger.
5	Default Gateway	Set the default gateway of the controller. Set the parameter based on the actual gateway of the router connected to the EzLogger.
6	Preferred DNS Server	Set the parameter as the IP address of the LAN's router when connecting to a public network, for example, connecting to GoodWe server, using a domain name for the server address.
7	Spare DNS Server	Ignore this parameter in common situations. When the preferred DNS server fails to resolve a domain name, use the alternate DNS server.
8	Local area network /	<ul style="list-style-type: none"> Select Internet to connect to the server and transfer data to the server.

Internet	<ul style="list-style-type: none"> Select local area network to configure forwarding parameters and connect to the third-party monitoring device.
----------	------------------------------------------------------------------------------------------------------------------------------------------------------------------

9.3.2 Set WiFi Password and SSID

NOTICE

- The in-built EzLogger of the controller provides a WiFi hotspot signal for local configuration. After connecting to the WiFi hotspot signal, you can commission the device through the web page.
- The WiFi signal SSID and password of the hotspot can be changed. After the change, log in to the web again using the new SSID and password.

Step 1 Go to **Device Maintenance > Port Setting > Wi-Fi Configuration** to set the parameters.

Step 2 Set the hotspot signal name and password based on actual needs.

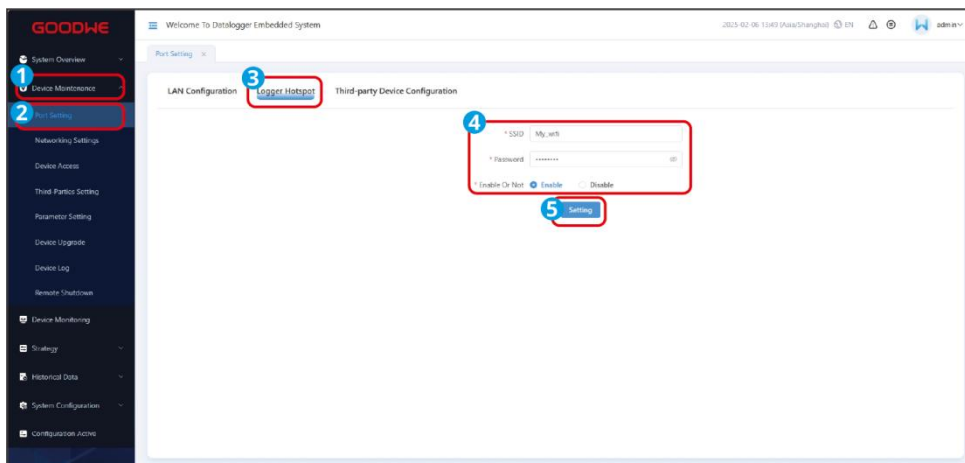

No.	Parameter	Description
1	SSID	WiFi signal name of the controller. Default name: Log-***.
2	Password	Hotspot password of the controller. Default password: 12345678.
3	Enable Or Not	Turn on or off the hotspot signal.

9.3.3 Configure RS485 Parameters

NOTICE

RS485 parameter needs to be configured when connecting the controller to the third-party device.

Step 1 Go to **Device Maintenance > Port Setting > RS485 Configuration** to set the parameters.

Step 2 Set the communication parameters based on actual needs.

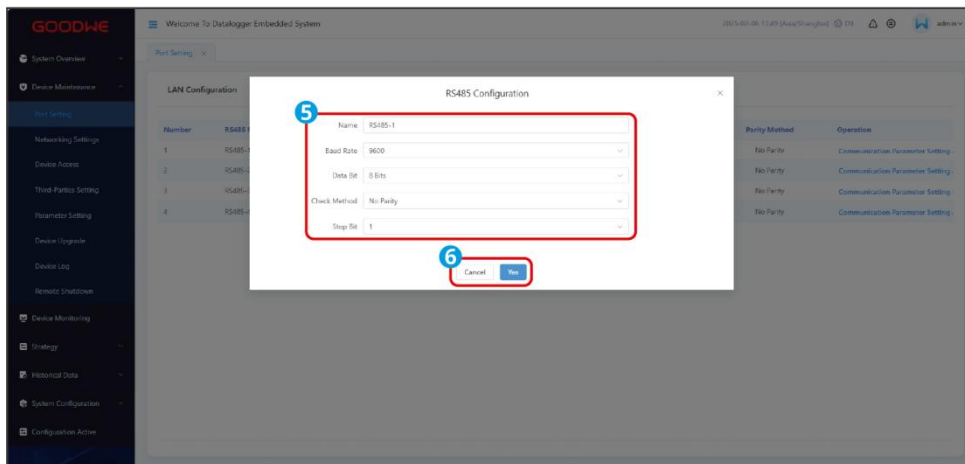
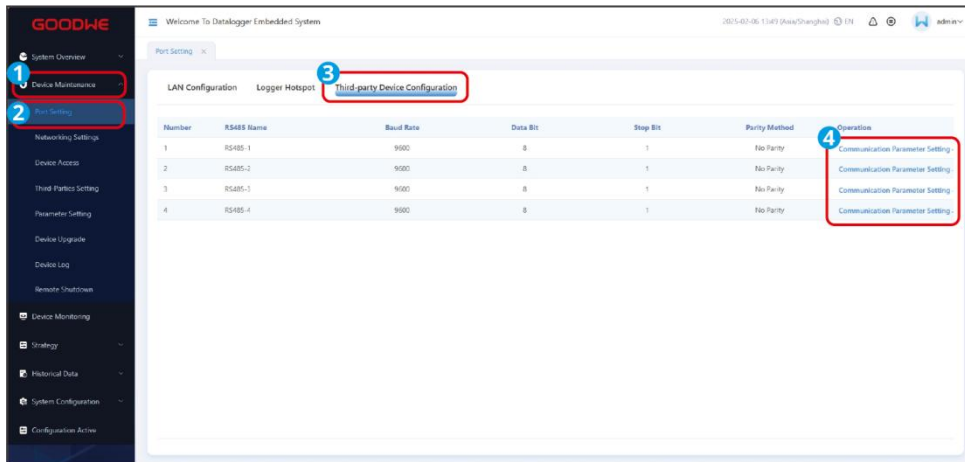

No.	Parameter	Description
1	Name	Select the actual connected RS485 port of the device.
2	Baud Rate	Set according to the baud rate of the connected equipment. Supported baud rate: 300, 1200, 2400, 4800, 9600, 19200.
3	Data Bit	Supported value: 7 bits or 8 bits.
4	Check Method	Set according to the check method of the connected equipment. Supported values: No Parity, Odd Parity, Even Parity, 1 Parity, or 0 Parity.
5	Stop Bit	Set according to the stop bit of the connected equipment. Supported values: 1, 1.5, and 2.

9.4 Set Third-Parties Parameters

9.4. 1 Set Modbus - TCP Parameters

Set third-parties parameters to forward the data collected by the controller to a third party management platform.

Step 1 Go to **Device Maintenance > Third-Parties Setting > Modbus-TCP** to set the parameters.

Step 2 Add Modbus - TCP channel and set the communication parameters based on actual needs.

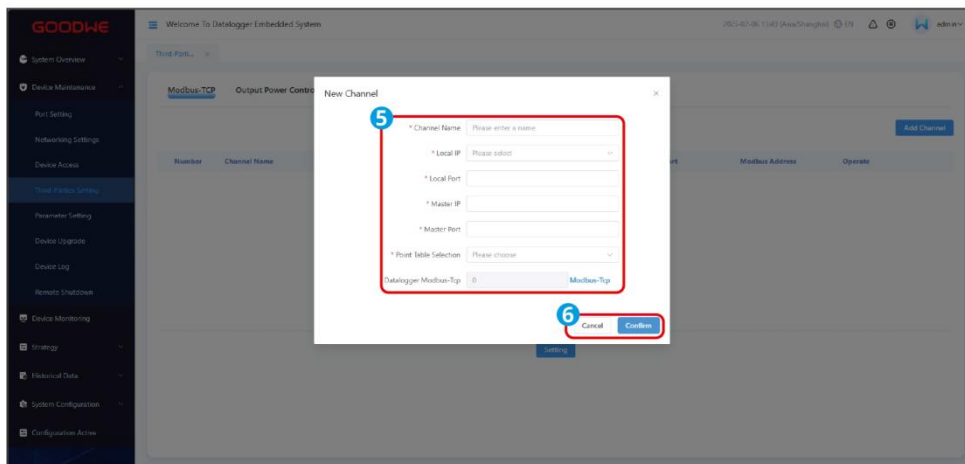
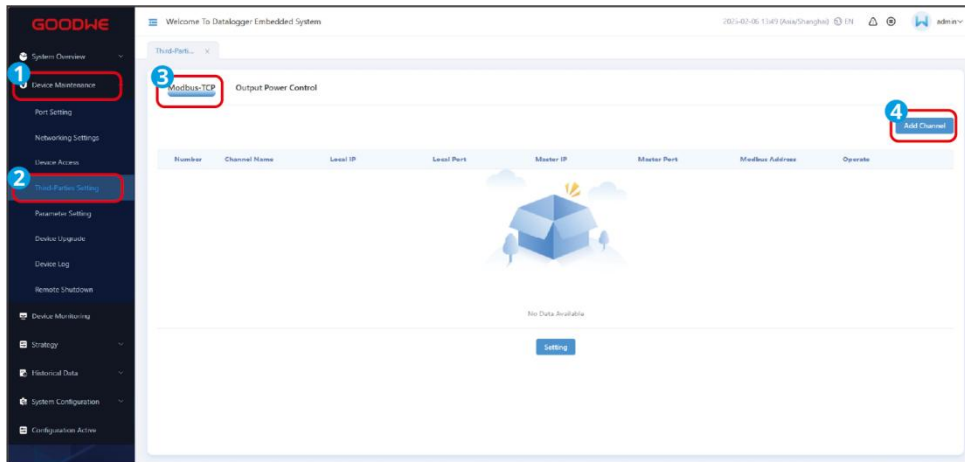

No.	Parameter	Description
1	Channel Name	Define the device name based on actual needs.
2	Local IP	Set the IP address of the controller.
3	Local Port	Set the port number of the controller. Default port number: 502.
4	Master IP	Set the IP address of the Modbus-TCP management system.
5	Master Port	Set the port number of the Modbus-TCP management system.
6	Port Table Selection	Select the access point table.
7	Datalogger Modbus-TCP	Set the address of the Modbus - TCP management system.

9.4. 2 Set Output Power Control Parameters

According to the requirements of Japan and other regions, set output control parameters when the device needs to communicate with utility grid company to realize output control function.

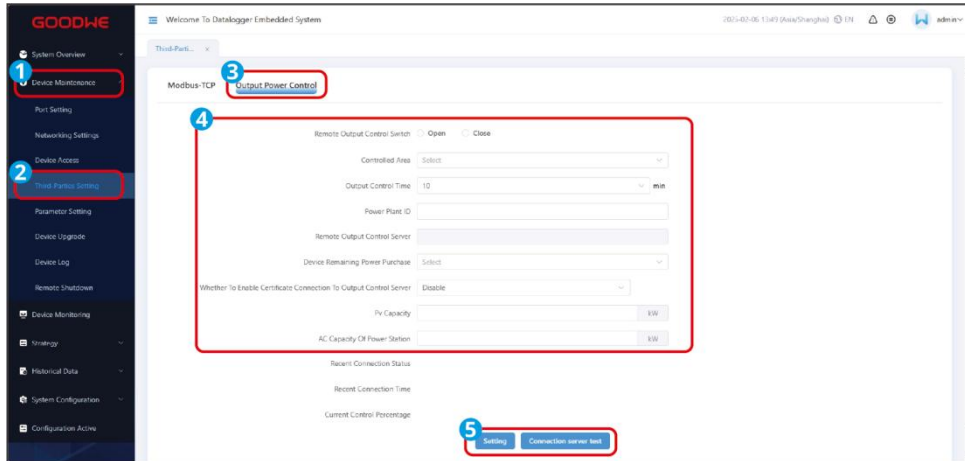

No.	Parameter	Description
1	Remote Output Control Switch	Enable or disable the output control function.
2	Controlled Area	Set the output control area. Supported: None, Kyushu, Chubu, Kansai, Shikoku, Hokkaido, Tokyo, Tohoku, etc.
3	Output Control Time	Set the output control duration, which refers to the time it takes for the inverter power
4	Power Plant ID	The ID assigned to the plant by the utility grid company after connecting its server.
5	Remote Output Control Server	The Remote Output Control Server will be generated automatically after setting the Control Region.
6	Device Remaining Power Purchase	Enable or disable the device remaining power purchase. After enabling, after the system generation power meets the load demand, the remaining power could be sold to the grid.
7	Whether to Enable Certificate Connection to Output Control	Choose whether to import and enable the certificate based on the actual situation.

	Server	
8	PV Capacity	Set as the total capacity of the PV panels.
9	AC Capacity of Power Station	Set as the AC capacity of the power station limited for feeding into the grid.

9.5 Set Device Parameters

9.5.1 Set EzLogger Parameters

Step 1 Go to **Device Maintenance > Parameter Setting > Datalogger** to set the parameters.

Step 2 Set the **size and quantity** of log files to be stored according to the actual needs.

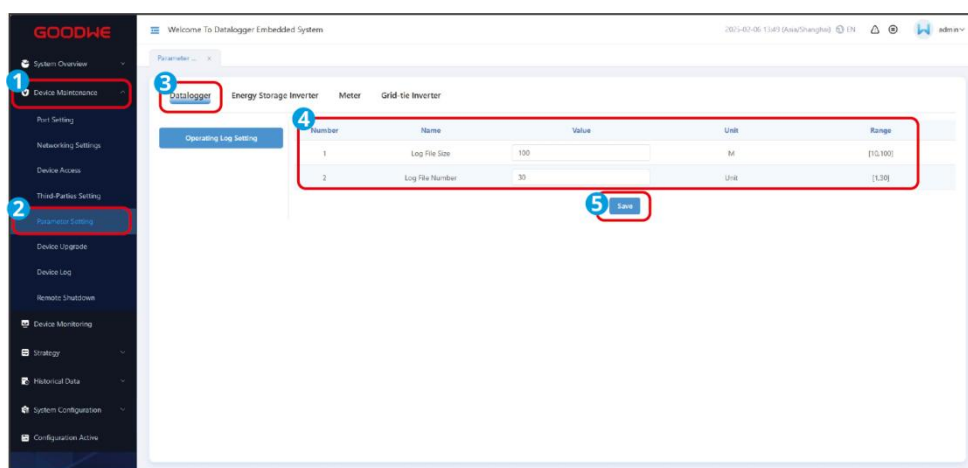

No.	Parameter	Description
1	Log File Size	Set the size and quantity of log files to be stored according to the actual needs.
2	Log File Number	

9.5.2 Set Parameters of Hybrid Inverters

9.5.2.1 Hybrid Inverter Configuration

Step 1 Go to **Device Maintenance > Parameter Setting > Energy Storage Inverter** to set the parameters.

Step 2 Select the device type, and click the inverter SN that you want to view or configure.

Step 3 Click **Create Quick Configuration** in **Quick Configuration**. Choose the Grid code and set the battery model based on actual needs. Click **Parameters Issued** to finish configuration.

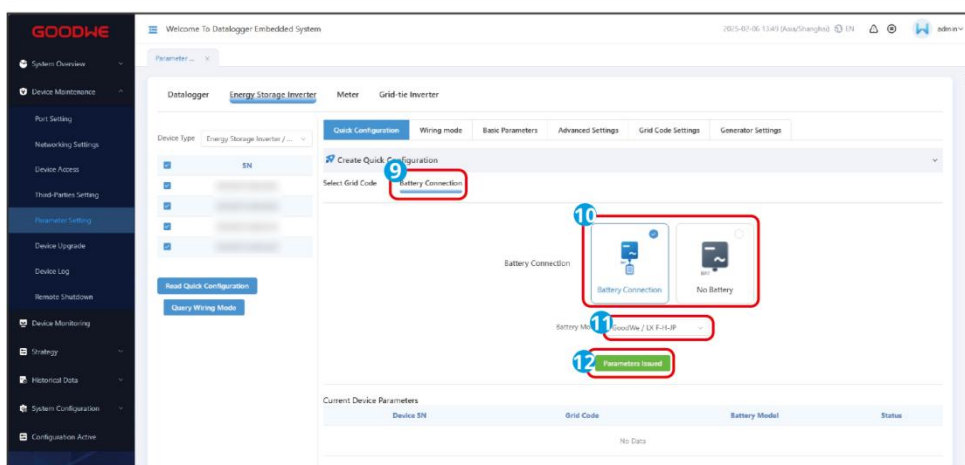
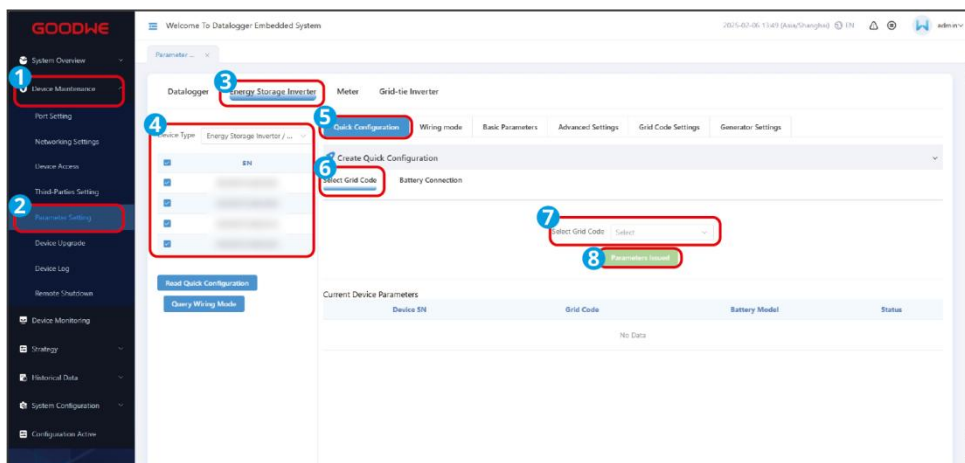

No.	Parameter	Description
1	Grid Code Settings	Select based on the grid codes of the country/region where the inverter is located and its application scenario.
2	Battery Connection	Choose the actual connection mode of the battery to the inverter. If there are no batteries connected in the system, then there is no need to configure the battery model and its working mode.

9.5.2.2 Set the Wiring Mode of Hybrid Inverters

Step 1 Go to **Device Maintenance > Parameter Setting > Energy Storage Inverter** to set the parameters.

Step 2 Select the device type, and click the inverter SN that you want to view or configure.

Step 3 Select **Wiring Mode**, choose the mode based on actual needs, click **Parameters Issued** to finish commissioning.

NOTICE

Only applicable to inverters of ET40-50kW series. Set this parameter when multiple inverters are in parallel.

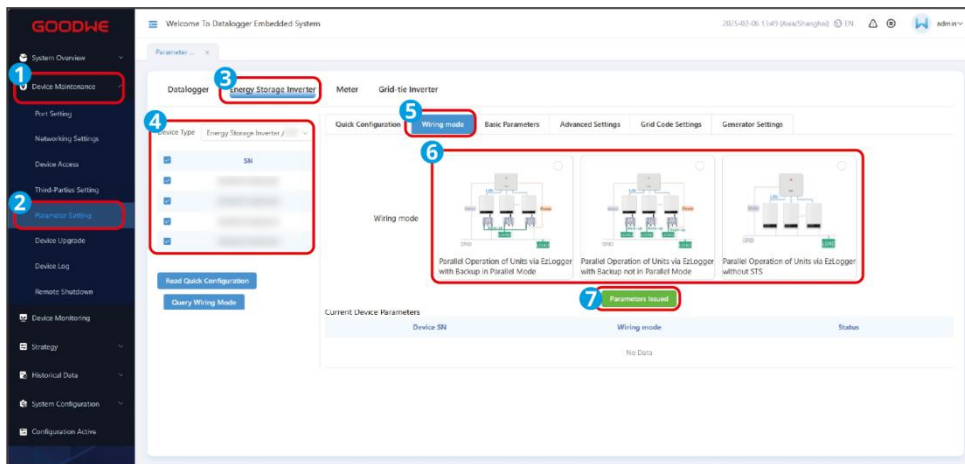

No.	Parameter	Description
1	Parallel Operation of Units via EzLogger with Backup in Parallel Mode	When the hybrid inverters are connected in parallel, both on-grid and off-grid, select Parallel Operation of Units via EzLogger with Backup in Parallel Mode.
2	Parallel Operation of Units via EzLogger with Backup not in Parallel Mode	If the hybrid inverters are connected in parallel when the system is on-grid, and separately when the system is off-grid, select Parallel Operation of Units via EzLogger with Backup not in Parallel Mode.
3	Parallel Operation of Units via EzLogger without STS	When the hybrid inverters are not connected to an STS, select Parallel Operation of Units via EzLogger without STS.

9.5.2.3 Set Basic Parameters of Hybrid Inverters

Step 1 Go to **Device Maintenance > Parameter Setting > Energy Storage Inverter** to set the parameters.

Step 2 Select the device type, and click the inverter SN that you want to view or configure.

Step 3 Check the parameters that you want to view or set, and click **Read** to check the current values of the selected parameters. If you need to modify, input the **Modification Items**, and click **Modify**, click **View Results** to check whether the modification is successful.

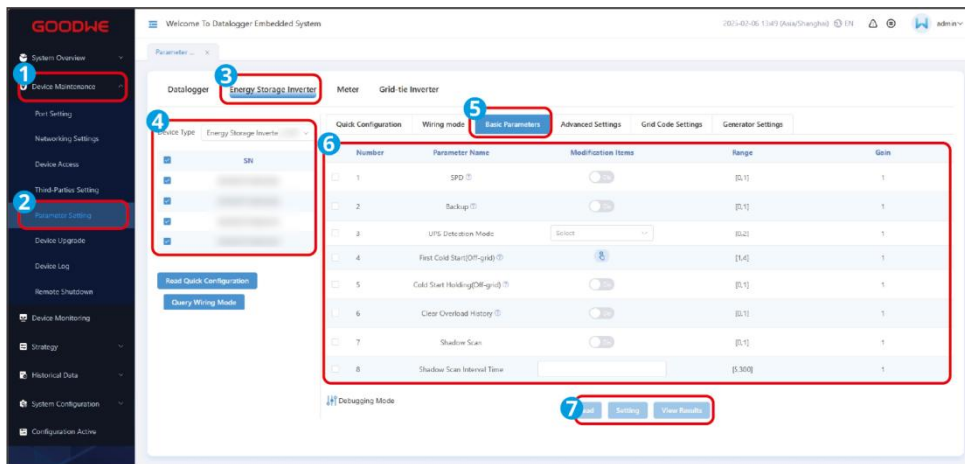

No.	Parameter	Description
1	SPD	After enabling SPD When the SPD module is abnormal, there will be SPD module exception alarm prompt.
2	Backup	After enabling Backup, the battery will power the load connected to the backup port of the inverter to ensure Uninterrupted Power Supply when the power grid fails.
3	UPS Detection Mode	<ul style="list-style-type: none"> ● UPS Mode - Full Wave Detection: Check whether the utility grid voltage is too high or too low. ● UPS Mode - Half Wave Detection: Check whether the utility grid voltage is too low. ● EPS Mode - Support LVRT: Close the utility grid and voltage detection.
4	First Cold Start (Off - grid)	Take effect once. In off-grid mode, enable First Cold Start (Off - grid) to output backup supply with battery or PV.
5	Cold Start Holding (Off-grid)	Take effect multiple times. In off-grid mode, enable First Cold Start (Off - grid) to output backup supply with battery or PV.
6	Clear Overload History	Once the power of loads connected to the inverter BACK-UP ports exceeds the rated load power, the inverter will restart and detect the power again. The inverter will perform restart and detection several times until the overloading problem is solved. Click Clear Overload History to clear the restart time interval after the power of the loads connected to the BACK-UP ports meets the requirements.
7	Shadow Scan	When PV panels are severely shadowed, enable this function to optimize power generation efficiency of the inverter. Set the Shadow Scan interval and MPPT shadow scan if the inverter supports.

9.5.2.4 Set Advanced Parameters of Hybrid Inverters

Step 1 Go to **Device Maintenance > Parameter Setting > Energy Storage Inverter** to set the parameters.

Step 2 Select the device type, and click the inverter SN that you want to view or configure.

Step 3 Check the parameters that you want to view or set, and click **Read** to check the current values of the selected parameters. If you need to modify, input the **Modification Items**, and click **Modify**, **click View Results** to check whether the modification is successful.

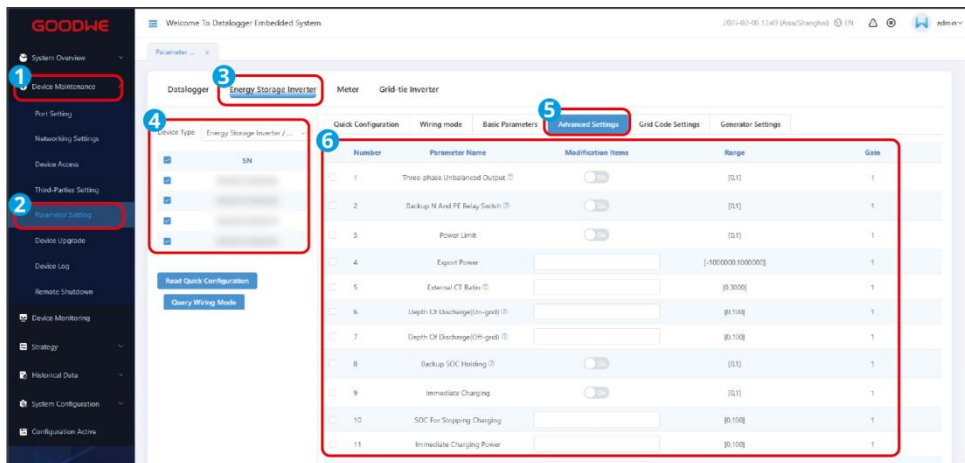

No.	Parameter	Description
1	Three-Phase Unbalanced Output	When the grid adopts phase-based metering, the three-phase imbalance function needs to be enabled.
2	Backup Power N and PE Relay Switch	According to the grid standards of certain countries or regions, when operating off-grid, the backup port's internal relay must remain closed to connect the N (Neutral) and PE wires.
3	Depth Of Discharge (On - grid)	Indicates the depth of discharge of the battery when the inverter is on-grid or off-grid.
4	Depth Of Discharge (Off - grid)	
5	Backup SOC Holding	The battery will be charged to preset SOC protection value by utility grid or PV when the system is running on-grid, so that the battery SOC is sufficient to maintain normal working when the system is off-grid.
6	Immediate	After enabling, the grid will immediately charge the battery. Take effect

	Charging	once. Start or stop based on actual needs.
7	SOC For Stopping Charging	Stop charging the battery once the battery SOC reaches SOC For Stopping Charging.
8	Immediate Charging Power	Indicates the percentage of the charging power to the inverter rated power when enabling Immediate Charging. For example, setting the Immediate Charging Power of a 10kW inverter to 60 means the charging power of the inverter is $10\text{kW} \times 60\% = 6\text{kW}$.
9	PV Connection Mode	<ul style="list-style-type: none"> ● Independent Connection: The PV string is connected to the inverter's MPPT port in a one-to-one correspondence. ● Partial Parallel Connection: One PV string connects to multiple MPPT ports of the inverter, while other PV modules connect to other MPPT ports of the inverter. ● Parallel Connection: External PV strings are connected to the inverter's PV input ports, with one PV string connected to multiple PV input ports.
10	PX Curve	After enabling, the inverter will adjust the three-phase power based on the grid voltage to maximize power utilization and minimize voltage rise. If the default value does not meet the requirements, the PX curve voltage threshold can be adjusted according to actual needs.

9.5.2.5 Set Parameters of Generator

Step 1 Go to **Device Maintenance > Parameter Setting > Energy Storage Inverter** to set the parameters.

Step 2 Select the device type, and click the inverter SN that you want to view or configure.

Step 3 Check the parameters that you want to view or set, and click **Read** to check the current values of the selected parameters. If you need to modify, input the **Modification Items**, and click **Modify**, click **View Results** to check whether the modification is successful.

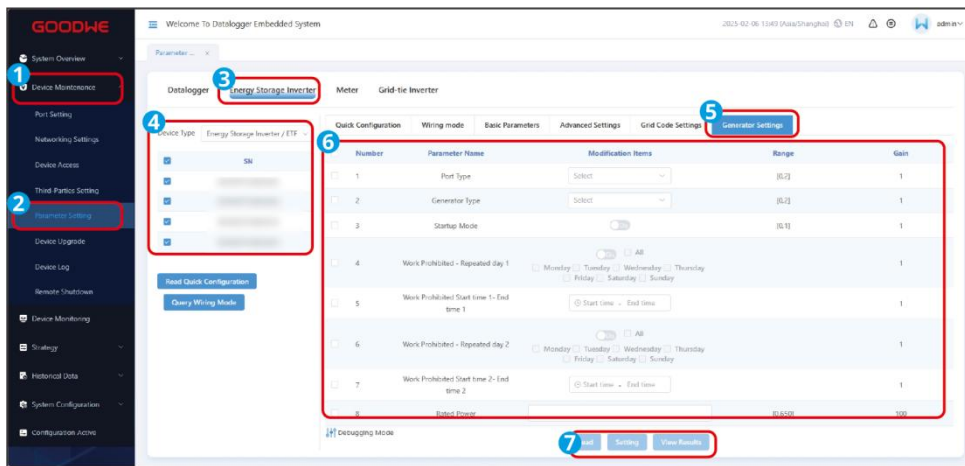

No.	Parameter	Description
1	Port Type	<ul style="list-style-type: none"> ● Generator Connection: The inverter is connected to the generator, controlling the generator's start and stop. ● Load Connection: The inverter is connected to a regular load, controlling the load's start and stop.
2	Generator Start Method	<ul style="list-style-type: none"> ● Automatic Control of Generator (Supports Dry Node Connection): The generator is automatically controlled to start and stop according to the set parameters. ● Manual Control of Generator (Does Not Support Dry Node Connection): The generator must be manually controlled to start and stop; the inverter cannot control the generator's operation. ● No Generator Installed: Select this option when no generator is connected to the system.
3	Generator Dry Node Switch	When the switch is turned on, the generator operates. After the set runtime, the generator can automatically stop.
4	Work Prohibited-Repeated	Set the dates on which the generator is prohibited from operating.
5	Work Prohibited Start Time-End Time	Set the time period during which the generator is prohibited from operating.
6	Rated Power	Set the rated power for generator operation.
7	Run Time	The generator's continuous operation time after it starts running. After the set time, the generator will stop. If the operation time includes a prohibited working time, the generator will stop during that period. After the prohibited time ends, the generator will restart and continue

		timing.
8	Voltage Upper Limit	Set the voltage range for the generator's operation.
9	Voltage Lower Limit	
10	Frequency Upper Limit	Set the frequency range for the generator's operation.
11	Frequency Lower Limit	
12	Preheating Time	Set the idle preheating time for the generator.
13	Maximum Charging Power	The charging power when the generator is charging the battery.

9.5.2.6 Set Grid Code Settings of Hybrid Inverters

NOTICE

Set the custom grid code settings in compliance with local requirements. Do not change the parameters without the prior consent of the grid company.

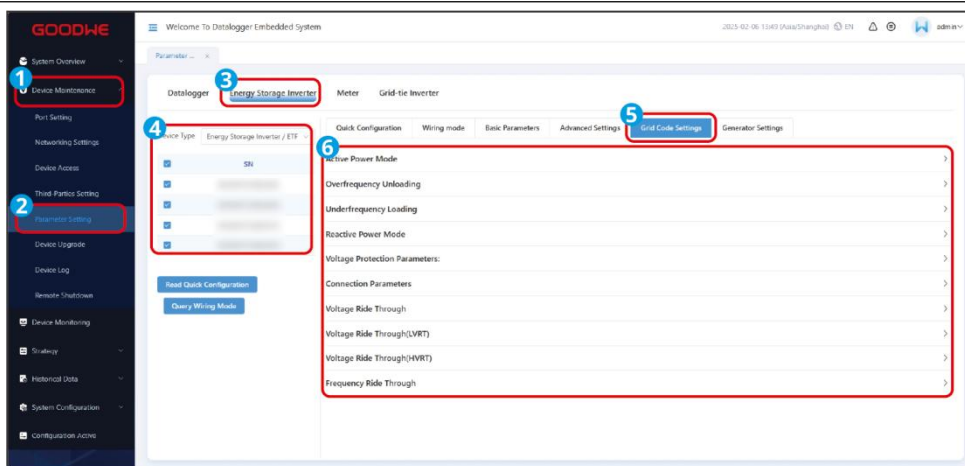

Active Power Mode

Step 1 Click **Device Maintenance >Parameter Setting > Energy Storage Inverter > Grid Code Setting > Active Power Mode** to set the parameters.

Step 2 Input the parameter based on actual needs.

No.	Parameter	Description
-----	-----------	-------------

1	Output the active power setting.	Set the output power limit of the inverter.
2	Power Gradient	Set the gradient when the active output power increases or decreases.

Overfrequency Unloading

Step 1 Click **Device Maintenance > Parameter Setting > Energy Storage Inverter > Grid Code Settings > Overfrequency Unloading** to set the parameters.

Step 2 Input the parameter based on actual needs.

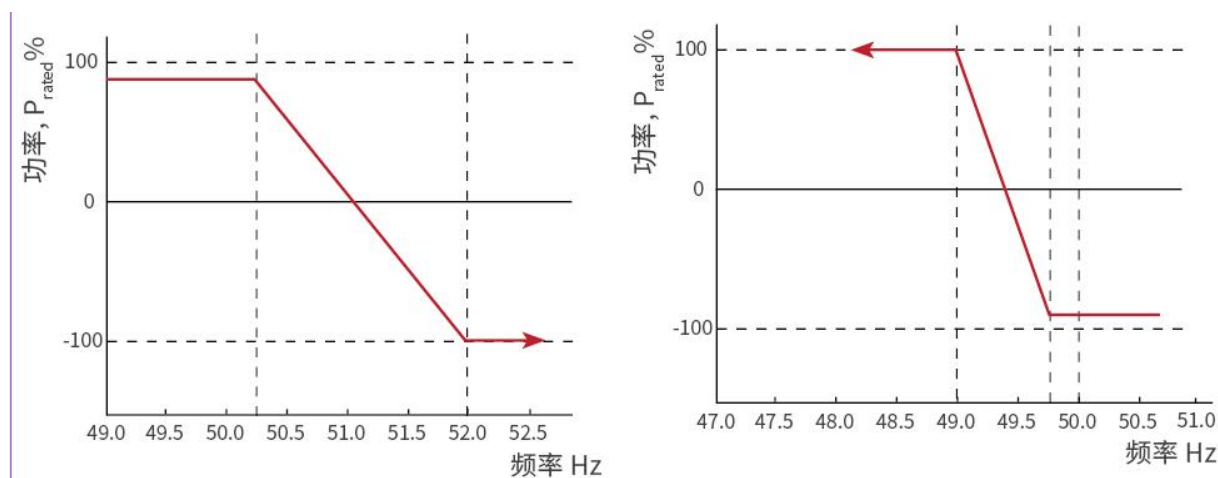

No.	Parameter	Description
1	P(F) Curve	Enable P(F) Curve when it is required by local grid standards and requirements.
2	Overfrequency Unloading Mode	Set this mode based on actual needs. Slope mode: Adjust the power based on overfrequency point and deloading slope. Stop mode: adjust the power based on overfrequency threshold and endpoint.
3	Overfrequency Threshold	The inverter output active power will decrease when the utility grid frequency is too high. The inverter output power will decrease when the utility grid frequency is higher than Overfrequency Threshold .
4	Buying and Selling Electricity Conversion Frequency	When the set frequency value is reached, the system switches from selling power to purchasing power. Supported: P _n rated power, P _s apparent power, P _m current power, P _{max} maximum power.

5	Overfrequency Endpoint	The inverter output active power will decrease when the utility grid frequency is too high. The inverter output power will stop decreasing when the utility grid frequency is higher than Overfrequency Endpoint.
6	Overfrequency power slope base power	Adjust the inverter output power based on Apparent Active Power, Rated Active Power, Momentary Active Power, Or Max. Active Power.
7	Power Response to Overfrequency Gradient	When the grid frequency exceeds the over-frequency point, the inverter output power will decrease according to the slope.
8	Tentional Delay Ta	Indicates the delayed response time when the inverter output power is higher than the Overfrequency Threshold .
9	Hysteresis Function Enable	Enable the hysteresis function.
10	Frequency Hysteresis Point	During the over-frequency derating process, if the frequency decreases, the power will output at the lowest derating point until the frequency drops below the hysteresis point, at which point the power will recover.
11	Delay Waiting Time	Namely, for over-frequency derating and frequency decrease and when the frequency is below the hysteresis point, the time to wait before power recovery starts.
12	Hysteresis Power Recovery Slope Benchmark	For over-frequency derating and frequency decrease, when the frequency drops below the hysteresis point, the recovery reference is calculated as recovery slope * reference power for power recovery. Supported: Pn rated power, Ps apparent power, Pm current power, Pmax maximum power, Power difference (ΔP).
13	Hysteresis Power Recovery Slope	For under-frequency loading and frequency increase, when the frequency exceeds the hysteresis point, the slope at which the power is recovered.

Underfrequency Loading

Step 1 Click **Home > Settings > Advanced Settings > Grid Code Settings > Active Curve** to set the parameters.

Step 2 Input the parameter based on actual needs.

P(F) Curve

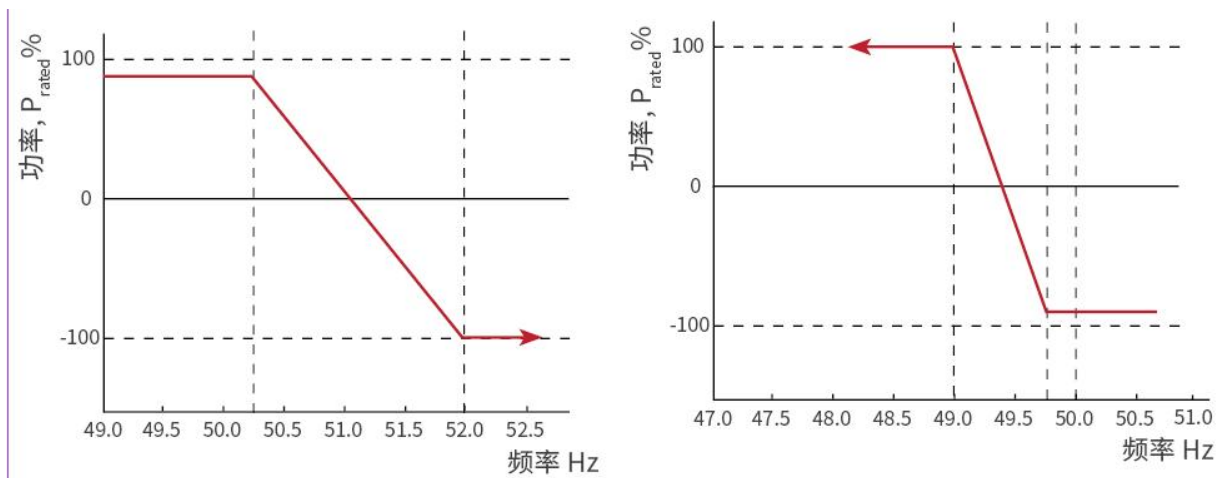

P(U) Curve

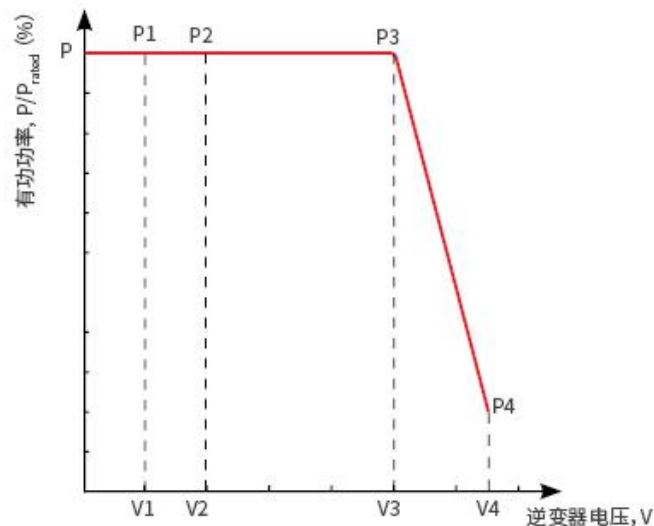

No.	Parameter	Description
1	P(F) Curve	Enable P(F) Curve when it is required by local grid standards and requirements.
2	Underfrequency Loading Mode	Set this mode based on actual needs. Slope mode: adjust power based on underfrequency and loading slope. Stop mode: adjust power based on underfrequency threshold and underfrequency endpoint.
3	Underfrequency Threshold	The inverter output active power will increase when the utility grid frequency is too low. The inverter output power will increase when the utility grid frequency is lower than the

		value.
4	Buying and Selling Electricity Conversion Frequency	When the set frequency value is reached, the system switches from selling power to purchasing power. Supported: Pn rated power, Ps apparent power, Pm current power, Pmax maximum power, power difference (ΔP).
5	Underfrequency Endpoint	The inverter output active power will increase when the utility grid frequency is too low. The inverter output power will stop decreasing when the utility grid frequency is higher than Overfrequency Endpoint.
6	Overfrequency power slope base power	Adjust the inverter output power based on Apparent Active Power, Rated Active Power, Momentary Active Power, Or Max. Active Power.
7	Power Response to Underfrequency Gradient	The inverter output active power will increase when the utility grid frequency is too low. The slope at which the inverter output power increases
8	Tentional Delay Ta	Indicates the delayed response time when the inverter output power is higher than the Overfrequency Threshold .
9	Hysteresis Function Enable	Enable the hysteresis function.
10	Frequency Hysteresis Point	During the under-frequency derating process, if the frequency increases, the power will output at the lowest derating point until the frequency is higher than the hysteresis point, at which point the power will recover.
11	Delay Waiting Time	Namely, for under-frequency derating and frequency increase and when the frequency is higher than the hysteresis point, the time to wait before power recovery starts.
12	Hysteresis Power Recovery Slope Benchmark	For under-frequency derating and frequency decrease, when the frequency is higher than the hysteresis point, the recovery reference is calculated as recovery slope * reference power for power recovery. Supported: Pn rated power, Ps apparent power, Pm current power, Pmax the maximum power, Power difference (ΔP) .
13	Hysteresis Power Recovery Slope	For under-frequency loading and frequency increase, when the frequency exceeds the hysteresis point, the slope at which the power is recovered.

14	Enable P(U) Curve	Enable P(U) Curve when it is required by local grid standards and requirements.
15	Vn Voltage	The percentage of actual voltage to the rated voltage at Vn point, n=1, 2, 3, 4. For example, setting Vn Voltage to 90 means $V/V_{rated}\%=90\%$.
16	Vn Active Power	The percentage of the output active power to the apparent power at Vn point, (n=1, 2, 3, 4). For example, setting Vn Active Power to 48.5 means $P/P_{rated}\%=48.5\%$
17	Output Response Mode	Set the active power output response mode. Supported: PT-1 Behavior, realize active scheduling based on the first-order LPF curve within the response time constant. Gradient Control, realize active scheduling based on the power change slope
18	Power Gradient	The active scheduling will be implemented based on the power gradient when the output response mode is set to slope scheduling.
19	PT-1 Behavior Tau	Set the time constant within which the active power changes based on the first order LPF curve when the Output Response Mode is set to be PT-1 Behavior.

Reactive Power Mode

Step 1 Click **Device Maintenance > Parameter Setting > Energy Storage Inverter > Grid Code Settings > Reactive Power Mode** to set the parameters.

Step 2 Input the parameter based on actual needs.

Q(U) Curve

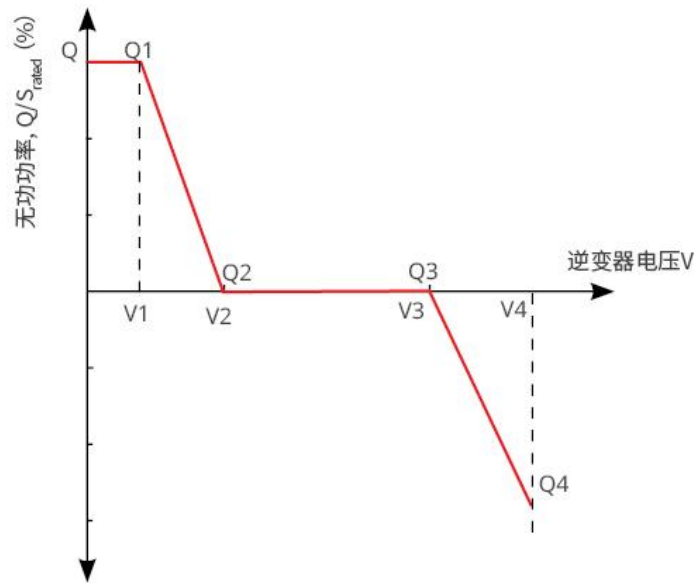

Cos (φ) Curve

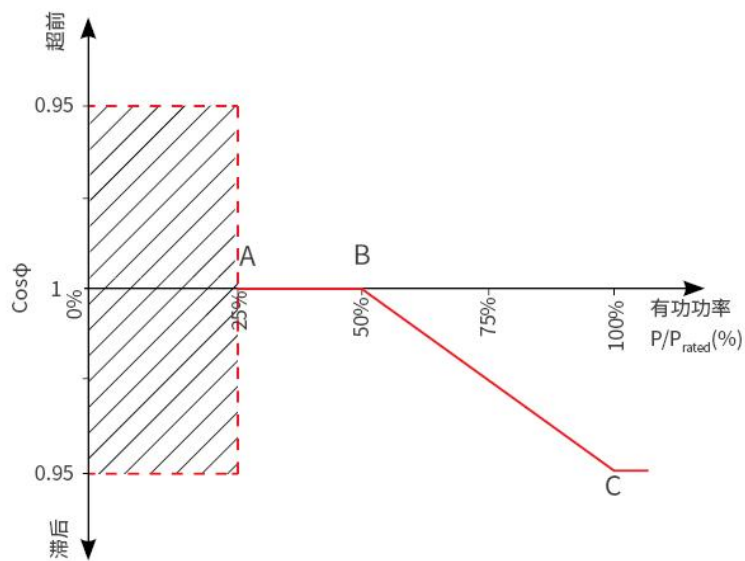

No.	Parameter	Description
1	Fix PF	Enable Fix PF when it is required by local grid standards and requirements.
2	Over-excited /Under-excited	Set the power factor as lagging or leading based on actual needs and local grid standards and requirements.
3	Power Factor	Set the power factor based on actual needs. Range: -1~-0.8, or +0.8~+1.
4	Fix Q	Enable Fix Q when it is required by local grid standards and

		requirements.
5	Over-excited /Under-excited	Set the reactive power as inductive or capacitive reactive power based on actual needs and local grid standards and requirements.
6	Reactive Power	The percentage of reactive power to the apparent power.
7	Enable Q(U) Curve	Enable Q(U) Curve when it is required by local grid standards and requirements.
8	Mode Option	Set Q (U) Curve mode. Supported: basic mode, slope mode.
9	Vn Voltage	The percentage of actual voltage to the rated voltage at Vn point, n=1, 2, 3, 4. For example, setting Vn Voltage to 90 means $V/V_{rated}=90\%$.
10	Vn Reactive Power	The percentage of the output reactive power to the apparent power at Vn point, (n=1, 2, 3, 4). For example, setting Vn Reactive Power to 48.5 means $Q/S_{rated}=48.5\%$
11	Voltage Dead Zone Width	When the Q(U) curve mode is set to slope mode, set the voltage dead zone. Within this dead zone, there is no requirement for reactive power output.
12	Overexcited Slope	In Q(U) curve mode set to slope mode, the power change slope is set to a positive or negative value.
13	Underexcited Slope	
14	Vn Reactive Power	The percentage of the output reactive power to the apparent power at Vn point, (n=1, 2, 3, 4). For example, setting Vn Reactive Power to 48.5 means $Q/S_{rated}=48.5\%$
15	Q(U) Curve Time Constant	The power is required to reach 95% in the first order LPF curve within three time constant.
16	Enable extension function	After enabling, set corresponding parameters.
17	Lock-In Power	When the inverter output reactive power to the rated power ratio is between the Lock-in power and Lock-out power, the ratio meets Q(U) curve requirements.
18	Lock-out Power	
19	Enable Cos φ (P) Curve	Enable Cos φ Curve when it is required by local grid standards and requirements.
20	Mode Option	Set cos φ (P) Curve mode. Supported: basic mode, slope



		mode.
21	Pn Power	The percentage of the output active power to the rated power at Pn point. N=A, B, C, D, E.
22	Pn Cos φ	Pn Power Factor N=A, B, C, D, E.
23	Overexcited Slope	In $\cos\varphi$ (P) curve mode set to slope mode, the power change slope is set to a positive or negative value.
24	Underexcited Slope	
25	Pn Power	The percentage of the output active power to the rated power at Pn point. N=A, B, C.
26	Pn Cos φ	Pn Power Factor N=A, B, C.
27	Cos φ (P) Curve Time Constant	The power is required to reach 95% in the first order LPF curve within three time constant.
28	Enable Extension Function	After enabling, set corresponding parameters.
29	Lock-in Voltage	When the grid voltage is between Lock-in Voltage and Lock-out Voltage, the voltage meets Cos φ curve requirements.
30	Lock-out Voltage	
31	Enable Q(P) Curve	Enable Q(P) Curve when it is required by local grid standards and requirements.
32	Mode Option	Set Q (P) Curve mode. Supported: basic mode, slope mode.
33	Pn Power	The percentage of the output reactive power to the apparent power at Pn point, n= 1, 2, 3, 4, 5, 6. For example, setting Pn Power to 90 means Q / Prated%=90%.
34	Pn Reactive Power	The percentage of the output active power to the rated power at Pn point, n=1, 2, 3, 4, 5, 6. For example, setting Pn Reactive Power to 90 means P / Prated%=90%.
35	Overexcited Slope	In Q(P) curve mode set to slope mode, the power change slope is set to a positive or negative value.
36	Underexcited Slope	
37	Pn Power	The percentage of the output reactive power to the apparent power at Pn point, n= 1, 2, 3. For example, setting Pn Power to 90 means Q /



		Prated%=90%.
38	Pn Reactive Power	The percentage of the output reactive power to the apparent power at Pn point, (n= 1, 2, 3). For example, setting Pn Reactive Power to 90 means $P / Prated\%=90\%$.
39	Time Constant	The power is required to reach 95% in the first order LPF curve within three time constant.

Voltage Protection Parameters

Step 1 Click **Device Maintenance > Parameter Setting > Energy Storage Inverter >Grid Code Settings >Voltage Protection Parameters** to set the parameters.

Step 2 Input the parameter based on actual needs.

No.	Parameter	Description
1	OV Trigger n-order Value	Set the OV n-order protection trigger threshold, n=1, 2, 3, 4.
2	OV Trigger n-order Trip Time	Set the OV trigger n-order trip time, n=1, 2, 3, 4.
3	UV Trigger n-order Value	Set the UV n-order protection threshold, n=1, 2, 3, 4.
4	UV Trigger n-order Trip Time	Set UV trigger n-order trip time, n=1, 2, 3, 4.
5	10-min OV Trigger Value	Set 10-min OV trigger value.
6	10-min OV Trip Time	Set the 10-min OV protection tripping time.
7	OF Stage n Trip Value	Set the grid overfrequency n-order protection threshold value, n=1, 2, 3, 4.
8	OF Stage n Trip Time	Set the grid overfrequency protection n-order tripping time, n=1, 2, 3, 4.
9	UF Stage n Trip Value	Set the grid underfrequency n-order protection threshold value, n=1, 2, 3, 4.
10	UF Stage n Trip Time	Set the grid underfrequency protection n-order tripping time., n=1, 2, 3, 4.

Connection Parameters

Step 1 Click **Device Maintenance > Parameter Setting > Energy Storage Inverter > Grid Code Settings > Connection** to set the parameters.

Step 2 Input the parameter based on actual needs.

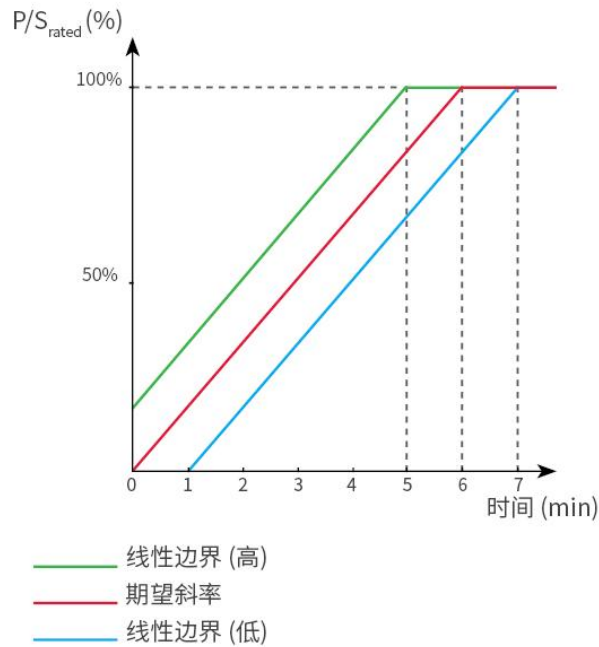

No.	Parameter	Description
1	Upper Voltage	The inverter cannot connect to the grid if it is powered on for the first connection and the grid voltage is higher than the Upper Voltage .
2	Lower Voltage	The inverter cannot connect to the grid if it is powered on for the first connection and the grid voltage is lower than the Lower Voltage .
3	Frequency Upper Limit	The inverter cannot be connected to the grid if it is powered on for the first connection and the grid frequency is higher than the Upper Frequency .
4	Frequency Lower Limit	The inverter cannot be connected to the grid if it is powered on for the first connection and the grid frequency is lower than the Lower Frequency .
5	Observation Time	The waiting time for connecting the inverter to the grid when meeting the following requirements: 1. The inverter is powered on for the first connection. 2. The utility grid voltage and frequency meet certain requirements.
6	Soft Ramp Up Gradient	Start Soft Ramp Up Gradient enabling
7	Soft Ramp Up Gradient	Indicates the percentage of incremental output power per minute based on the local requirements when the inverter is powered on for the first time.

		For example, setting Soft Ramp Up Gradient to 10 means the start-up slope is 10% Prated/min.
8	Fault Condition Connection Voltage Upper Limit	When the inverter experiences a fault and reconnects to the grid, if the grid voltage is higher than this value, the inverter will not be able to be connected to the grid.
9	Fault Condition Connection Voltage Lower Limit	When the inverter experiences a fault and reconnects to the grid, if the grid voltage is lower than this value, the inverter will not be able to be connected to the grid.
10	Fault Condition Connection Frequency Upper Limit	When the inverter experiences a fault and reconnects to the grid, if the grid frequency is higher than this value, the inverter will not be able to be connected to the grid.
11	Fault Condition Connection Frequency Lower Limit	When the inverter experiences a fault and reconnects to the grid, if the grid frequency is lower than this value, the inverter will not be able to be connected to the grid.
12	Fault Condition Grid Connection Observation Time	When the inverter experiences a fault and reconnects to the grid, this is the waiting time before the inverter connects to the grid, once the grid voltage and frequency meet the grid connection requirements.
13	Reconnection Load Slope Enable	Start Soft Ramp Up Gradient Enable
14	Reconnection Power Loading Slope	In some countries/regions, set the percentage of incremental output power per minute when the inverter is not powered on for the first connection. For example, setting Reconnection Power Loading Slope to 10 means the reconnection slope is 10% Prated/min.

Voltage Ride Through

Step 1 Click **Device Maintenance > Parameter Setting > Energy Storage Inverter > Grid Code Settings > Voltage Ride through** to set the parameters.

Step 2 Input the parameter based on actual needs.

No.	Parameter	Description
-----	-----------	-------------

1	Current Distribution Mode	Set the current distribution mode. Supported: Constant Current Mode, Reactive Current Priority Mode, and Active Current Priority Mode.
2	Active Power Recovery Mode After Crossing Mode	Set the active power recover mode after LVRT or HVRT. Supported: Disable, Gradient Control, or PT-1 Behavior.
3	Power Gradient	Realize active power recovery based on the power change slope.
4	PT-1 Behavior Tau	Set the time constant within which the active power changes based on the first order LPF curve.
5	Traversing The End Of Reactive Power Recovery Mode	Set the active power recover mode after LVRT or HVRT. Supported: Disable, Gradient Control, or PT-1 Behavior.
6	Power Change Gradient	Realize reactive power recovery based on the power change slope
7	PT-1 Behavior Tau	Set the time constant within which the reactive power changes based on the first order LPF curve.

Voltage Ride Through (LVRT)

LVRT: Low Voltage Ride Through, which means when a temporary low voltage occurs due to grid abnormalities, the inverter cannot immediately disconnect from the grid and must support the grid for a certain period of time.

Step 1 Click **Device Maintenance > Parameter Setting > Energy Storage Inverter > Grid Code Settings > Voltage Ride Through (LVRT)**

to set the parameters.

Step 2 Input the parameter based on actual needs.

No.	Parameter	Description
1	LVRT	Enable LVRT Enabling.
2	UVn Voltage	The ratio of the ride through voltage to the rated voltage at UVn point during LVRT. n=1,2,3,4,5,6,7.
3	UVn Time	The ride through time at UVn point during LVRT. n=1,2,3,4,5,6,7
4	Entry Threshold	The inverter will not be disconnected from the utility grid immediately when the grid voltage is between Enter Low Crossing Threshold and Exit Low Crossing Threshold .
5	Exit LVRT	



	Endpoint	
6	Gradient K1	K-factor for reactive power during LVRT.
7	Enable Zero Current Mode	The system outputs zero current during LVRT.
8	Enter Threshold	Set the entry threshold of zero current mode

Voltage Ride Through (HVRT)

HVRT: High Voltage Ride Through, which means when a temporary high voltage occurs due to grid abnormalities, the inverter cannot immediately disconnect from the grid and must support the grid for a certain period of time.

Step 1 Click **Device Maintenance > Parameter Setting > Energy Storage Inverter > Grid Code Settings > Voltage Ride Through (HVRT)** to set the parameters.

Step 2 Input the parameter based on actual needs.

No.	Parameter	Description
1	HVRT	Enable LVRT Enabling.
2	OVn Voltage	The ratio of the ride through voltage to the rated voltage at OVn point during HVRT. n=1,2,3,4,5,6,7.
3	OVn Time	The ride through time at UVn point during HVRT. n=1,2,3,4,5,6,7
4	Entry Threshold	The inverter will not be disconnected from the utility grid immediately when the grid voltage is between Enter High Crossing Threshold and Exit High Crossing Threshold .
5	Exit HVRT Endpoint	
6	Gradient K2	K-factor for reactive power during HVRT.
7	Enable Zero Current Mode	The system outputs zero current during HVRT.
8	Enter Threshold	Set the entry threshold of zero current mode

Frequency Ride Through

Step 1 Click **Device Maintenance > Parameter Setting > Energy Storage Inverter > Grid Code Settings > Frequency Ride Through** to set the parameters.

Step 2 Input the parameter based on actual needs.

No.	Parameter	Description
1	Frequency Ride Through	Enable Frequency Ride Through Enabling.
2	UFn Frequency	The frequency at the UFn point during frequency ride through.

		n=1,2,3
3	UFn Time	The ride through duration at the UFn point during frequency ride through. n=1,2,3
4	OFn Frequency	The frequency at the OFn point during frequency ride through. n=1,2,3
5	OFn Time	The ride through duration at the OFn point during frequency ride through. n=1,2,3

9.5. 3 Set Meter Parameters

Step 1 Go to **Device Maintenance > Parameter Setting > Meter** to set the parameters.

Step 2 Select the meter that you want to view or configure.

Step 3 Check the parameters that you want to view or set, and click **Search** to check the current values of the selected parameters. To modify, enter the **Modification Value** and click **Setting** to apply the changes.

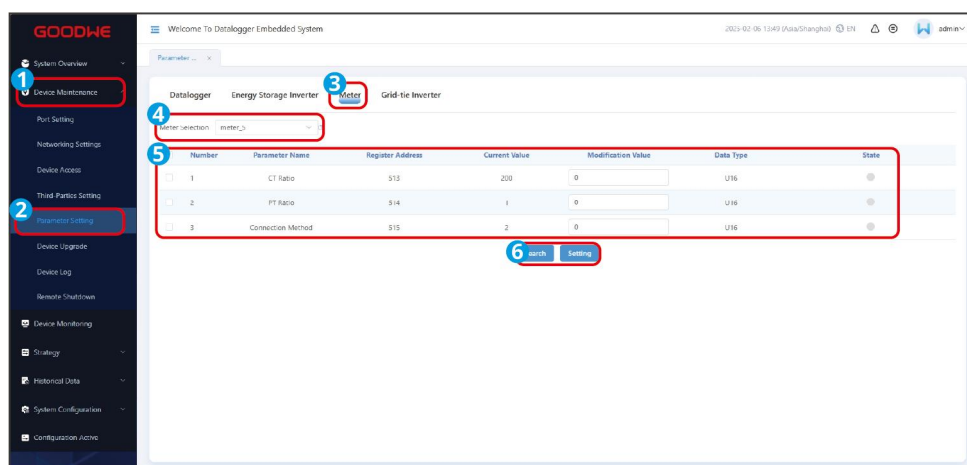

No.	Parameter	Description
1	CT Ratio	Set the ratio of the primary current to the secondary current of the CT.
2	PT Ratio	Set the ratio of the primary voltage to the secondary voltage of the PT.
3	Connection Method	Set the connection method of the meter according to the real situation.

9.5. 4 Set Parameters of Grid-tied Inverters

NOTICE

- Parameters needed to be set vary among different inverter models. The actual setting

interface prevails.

- Enter 0 or 1 to enable or disable a function. 0 indicates disabling the function, and 1 indicates enabling the function.

Step 1 Go to **Device Maintenance > Parameter Setting > Grid-tie inverter** to set the parameters.

Step 2 Select the device type, and click the inverter SN that you want to view or configure.

Step 3 Check the parameters that you want to view or set, and click **Search** to check the current values of the selected parameters. If you need to modify, input the **Modified Value**, and click **Modify**, click **View Results** to check whether the modification is successful.

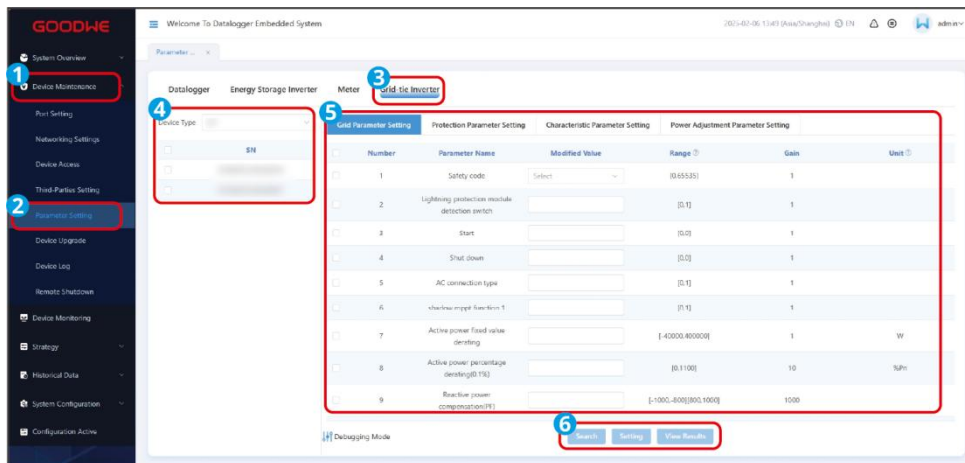

Grid Parameter Setting

No.	Parameter	Description
1	Safety Code	Select based on the grid standards of the country/region where the inverter is located and its application scenario.
2	Lightning Protection Module Detection Switch	Enable or disable SPD detection function.
3	Start	Issue power on instructions.
4	Shut down	Issue power off instructions.
5	AC Connection Type	<ul style="list-style-type: none"> ● Set whether the inverter's output includes the neutral (N) cable based on its application scenario. ● 0: three-phase four wire (3W/PE); 1: three phase five wire (3W/N/PE).
6	MPPT Shadow Scan Function Switch	PV strings may exist significant shading in PV systems where the inverter is applied. Enabling this feature allows the inverter to perform a global MPPT scan at regular intervals to find the maximum power point.

7	Active Power Fixed Value Derating	Adjust the active power output of the inverter by percentage of rated power.
8	Active Power Percentage Derating	Adjust the active power output of the inverter by percentage of rated power.
9	Reactive Power Compensation (PF)	Set the power factor of the inverter.
10	Reactive Power Compensation (Q/S)	Set the reactive power output from the inverter.
11	Reactive Power Compensation Fixed Value	Adjust the reactive power output of the inverter by fixed value.
12	Night Reactive Power Function Enabling	Enable or disable night reactive power function. In some specific application scenarios, the power grid company requires that the inverter can perform reactive power compensation at night to ensure that the power factor of the local power grid meets requirements.
13	Night Reactive Power Parameters Taking Effect	When enabling this function, the inverter outputs reactive power based on fixed value of night reactive power scheduling compensation. Otherwise, the inverter executes the remote scheduling command.
14	Percentage of Night Reactive Power Scheduling	Schedule the reactive power by percentage during night reactive scheduling period.
15	Night Reactive Power Scheduling	Schedule the reactive power by fixed value during night reactive scheduling period.

Characteristic Parameter Setting

No.	Parameter	Description
1	European shutdown switch	Enable or disable remote shutdown function.
2	Anti-PID Function Switch	Enable or disable anti-PID.
3	PID Repair	Enable or disable PID recovery.

	Function Switch	
4	Power Limit Switch	Enable or disable power limit.
5	Back Flow Power Percentage Setting	Set the back flow power by percentage.
6	Three-phase Power Limit Method Selection	Set the power limit mode. 0: the total power of the three phases cannot exceed the power limit. 1: power of any phase cannot exceed the power limit.
7	External Meter CT Ratio	Set the CT ratio of the smart meter.
8	ISO Threshold	To protect the equipment, the inverter performs an insulation impedance check on the input side during self-check at startup. If the measured value is lower than the set value, the inverter will not connect to the grid.
9	NPE Overvoltage Detection Switch	Enable or disable N-PE overvoltage detection.
10	N-PE Fault Limit	Set the N-PE overvoltage alarm threshold.
11	Active Power Scheduling Response Method	<ul style="list-style-type: none"> ● Set the active power scheduling response method. Supported method: gradient control or PT-1 behavior. ● 0: disable; 1: gradient control; 2: PT-1 behavior tau; 3: PT-1 behavior respond time.
12	Active Power Gradeint	Set the active power change slope.
13	Active Power Scheduling LPF Time	Set the low pass filtering time for active power scheduling.
14	Reactive Scheduling Response Method	<ul style="list-style-type: none"> ● Set the reactive power scheduling response method. Supported method: gradient control or PT-1 behavior. ● 0: disable; 1: gradient control; 2: PT-1 behavior tau; 3: PT-1 behavior respond time.
15	Reactive Power Gradient	Set the reactive power change slope.
16	Set the low pass	Set the low pass filtering time parameter for reactive power



	filtering time parameter for reactive power scheduling	scheduling.
--	--------------------------------------------------------	-------------

Protection Parameter Setting

No.	Parameter	Description
1	Overtoltage Trigger n-order Value	Set the Level n overvoltage protection threshold. n=1,2.
2	Overtoltage Trigger n-order Trip Time	Set the Level n overvoltage protection duration. n=1,2.
3	Undervoltage Trigger n-order Value	Set the Level n undervoltage protection threshold. n=1,2.
4	Undervoltage Trigger n-order Trip Time	Set the Level n undervoltage protection duration. n=1,2.
5	Phase voltage Level n Overtoltage Protection Value	Set the grid's Level n overvoltage protection point. n=3,4.
6	Set the Level n overvoltage protection duration	Set the Level n overvoltage protection duration. n=3,4.
7	10-min Overtoltage Trigger Value	Set the 10-min overvoltage protection threshold.
8	10-min Overtoltage Trip Time	Set the 10-min overvoltage protection duration.
9	OF Stage n Trip Value	Set the Level n overfrequency protection threshold. n=1,2.
10	OF Stage n Trip	Set the Level n overfrequency protection duration. n=1,2.



	Time	
11	UF Stage n Trip Value	Set the Level n underfrequency protection threshold. n=1,2.
12	UF Stage n Trip Time	Set the Level n underfrequency protection duration. n=1,2.
13	Set the Level n overfrequency protection threshold.	Set the Level n overfrequency protection threshold. n=3,4.
14	Set the Level n overfrequency protection duration	Set the Level n overfrequency protection duration. n=3,4.
15	Level n underfrequency protection threshold.	Set the Level n underfrequency protection threshold. n=3,4.
16	Level n underfrequency protection duration.	Set the Level n underfrequency protection duration. n=3,4.
17	Start-up Grid Connection Voltage Upper Limit	The inverter cannot be connected to the grid if it is powered on for the first connection and the grid voltage is higher than the Start-up Grid Connection Voltage Upper Limit .
18	Start-up Grid Connection Voltage Lower Limit	The inverter cannot be connected to the grid if it is powered on for the first connection and the grid voltage is lower than the Start-up Grid Connection Voltage Lower Limit .
19	Start-up Grid Connection Frequency Upper Limit	The inverter cannot be connected to the grid if it is powered on for the first connection and the grid frequency is higher than the Start-up Grid Connection Frequency Upper Limit .
20	Start-up Grid Connection	The inverter cannot be connected to the grid if it is powered on for the first connection and the grid voltage is lower than the Start-up



	Frequency Lower Limit	Grid Connection Frequency Lower Limit.
21	Start-up Grid Connection Observation Time	Set the waiting time for connecting the inverter to the grid when the inverter is powered on for the first connection.
22	Start-up Grid Connection Power Loading Rate	Set the percentage of incremental output power per minute when the inverter is powered on for the first connection.
23	Reconnection Voltage Upper Limit	In some countries/regions, when the inverter is shut down due to a fault protection, it is not allowed to reconnect to the grid if the grid voltage is higher than the set value of the Reconnection Voltage Upper Limit.
24	Reconnection Voltage Lower Limit	In some countries/regions, when the inverter is shut down due to a fault protection, it is not allowed to reconnect to the grid if the grid voltage is lower than the set value of the Reconnection Voltage Lower Limit.
25	Reconnection Frequency Upper Limit	In some countries/regions, when the inverter is shut down due to a fault protection, it is not allowed to reconnect to the grid if the grid voltage is higher than the set value of the Reconnection Frequency Upper Limit.
26	Reconnection Frequency Lower Limit	In some countries/regions, when the inverter is shut down due to a fault protection, it is not allowed to reconnect to the grid if the grid voltage is lower than the set value of the Reconnection Frequency Lower Limit.
27	Reconnection Observation Time	Set the waiting time for the inverter to restart after a grid failure is restored.
28	Reconnection Power Loading Rate	In some countries/regions, set the percentage of incremental output power per minute when the inverter is not powered on for the first connection. For example, setting Reconnection Power Loading Rate to 10 means the reconnection slope is 10% Prated/min.
29	LVRT Enable	LVRT: Low Voltage Ride Through, which means when a temporary low voltage occurs due to grid abnormalities, the inverter cannot immediately disconnect from the grid and must support the grid for a certain period of time. Enable this function, the inverter's LVRT is being activated.
30	LVRT Depth n	The ratio of the ride through voltage to the rated voltage at a feature point during LVRT. n=1,2,3,4,5,6,7.
31	Maintenance Time n	The ride through time at a feature point during LVRT. n=1,2,3,4,5,6,7.



32	Judgment Threshold of Entering LVRT	Set the threshold for triggering LVRT. The threshold settings should meet the local grid standard.
33	Judgment Threshold of Quitting LVRT	Set the threshold for exiting LVRT. The threshold settings should meet the local grid standard.
34	Positive sequence K value of LVRT	During LVRT, the inverter needs to generate positive sequence reactive power to support the grid. This parameter is used to set the positive-sequence reactive power generated by the inverter.
35	0-current mode of LVRT	The standards of some countries/regions require that the output current during LVRT should be limited. After enabling, the output current is less than 10% of the rated current during LVRT.
36	Threshold of Entering Voltage	After enabling LVRT Zero Current Mode , the zero current mode starts if the power grid voltage is less than LVRT Zero Current Mode Enable , the zero current mode starts if the power grid voltage is less than the Threshold of Entering Voltage during LVRT.
37	HVRT Enable	HVRT: High Voltage Ride Through, which means when the grid experiences a short-term high voltage abnormality, the inverter cannot immediately disconnect from the grid and has to work for a period of time. Enable this function, the inverter's HVRT is being activated.
38	HVRT Depth n	The ratio of the ride through voltage to the rated voltage at a feature point during HVRT, n=1,2,3,4,5,6,7.
39	HVRT Maintenance Time n	The ride through time at a feature point during HVRT. n=1,2,3,4,5,6,7.
40	Judgment Threshold of Entering HVRT	Set the threshold for triggering HVRT. The threshold settings should meet the local grid standard.
41	Judgment Threshold of Quitting HVRT	Set the threshold for exiting HVRT. The threshold settings should meet the local grid standard.
42	Positive sequence K value of HVRT	During HVRT, the inverter needs to generate positive sequence reactive power to support the grid. This parameter is used to set the positive-sequence reactive power generated by the inverter.
43	Positive sequence K value of HVRT	The standards of some countries/regions require that the output current during HVRT should be limited. Enable this function to set the output current less than 10% of the rated current during HVRT.
44	Threshold of Entering Voltage	After enabling HVRT Zero Current Mode , the zero current mode starts if the power grid voltage is higher than Threshold of Entering



		Voltage during HVRT.
45	Current Distribution Mode	<ul style="list-style-type: none"> ● Set the sharing mode of reactive current and active current. ● 0: reactive power priority; 1: active power priority; 2: constant current mode.
46	Active Power Recovery Mode After Crossing	<ul style="list-style-type: none"> ● Active current recovery mode during ride-through recovery, supported mode: slope recovery, first-order LPF recovery, and no requirement. ● 0: disable; 1: slope response; 2: time constant; 3: respond time
47	Active Power Recovery Rate After Riding Through	The rate at which the active current recovers during the ride through recovery process.
48	Active Power Recovery First-order LPF After Riding Through	The active current recovers at the characteristic of first order LPF after the ride through recovery.
49	Traversing The End Of Reactive Power Recovery Mode	<ul style="list-style-type: none"> ● Reactive current recovery mode during ride-through recovery, supported mode: slope recovery, first-order LPF recovery, and no requirement. ● 0: disable; 1: slope response; 2: time constant; 3: respond time
50	Reactive Power Recovery Rate After Riding Through	The reactive current recovers at the slope after the ride through recovery.
51	Reactive Power Recovery First-order LPF After Riding Through	The reactive current recovers at the characteristic of first order LPF after the ride through recovery.
52	Frequency Riding Through Enable	After enabling Frequency Riding Through Enable, the inverter continues to generate power during required time even the grid frequency is abnormal.
53	N-order Under Frequency Riding Through Point_UFn	Trigger the underfrequency riding through frequency point.
54	N-order Under Frequency Riding Through Time_UTn	Set the underfrequency protection tripping time.
55	N-order Over Frequency Riding	Set the overfrequency riding through frequency point.

	Through Point_OFn	
56	N-order Over Frequency Riding Through Time_OTn	Set the overfrequency protection tripping time.

Power Adjustment Parameter Setting

No.	Parameter	Description
1	Overfrequency Threshold (slope mode)	In some countries/regions, the active power of the device will be derated when the grid frequency exceeds overfrequency derating limit.
2	Over Frequency Deloading Slope (slope mode)	In slope mode, the active power of the device will be derated according to a certain slope when the grid frequency is higher than overfrequency derating limit.
3	P-F Curve (Overfrequency)	Enable or disable overfrequency deloading.
4	Underfrequency Threshold (slope mode)	In some countries/regions, the active power of the device will be derated when the grid frequency exceeds overfrequency derating limit.
5	Power Recovery Slope	Set power recovery slope at which
6	Frequency Hysteresis Point	Function Frequency Corresponding Point.
7	Tentional Delay Ta	The tentional observation time for the underfrequency hysteresis function.
8	Overfrequency Endpoint	Set the exit frequency for over-frequency derating.

9.6 Set Remote Shutdown

9.6. 1 Set OVGR&RPR

The standards of Japan and some other regions require that the OVGR/RPR can be connected to any DI port of the controller to shut down the inverter over OVGR/RPR signals.

Step 1 Click **Device Maintenance > Port Setting >OVGR&RPR** to set the parameters.

Step 2 Set remote shutdown and port status based on actual needs.

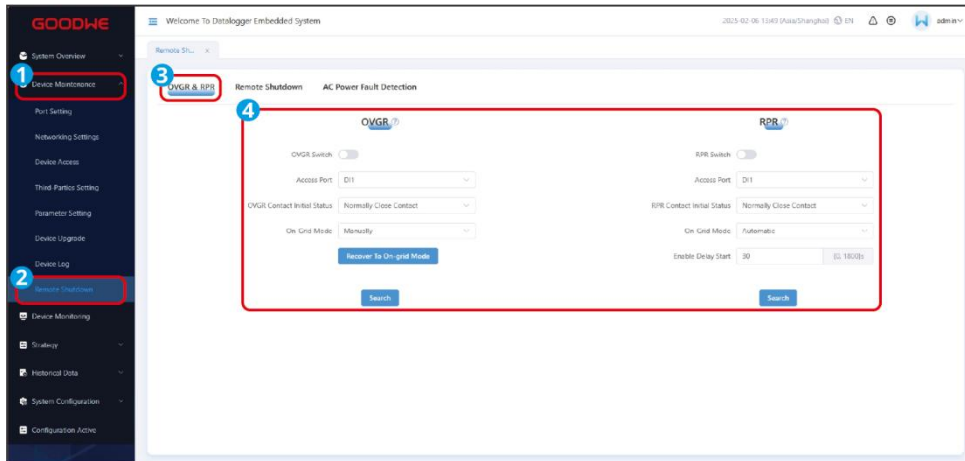

No.	Parameter	Description
OVGR		
1	OVGR Switch	Enable or disable the output control function.
2	Access Port	Select the actual port on the EzLogger to which the OVGR is connected. Supported: DI1, DI2, DI3, DI4.
3	OVGR Contact Initial Status	Set the initial status of OVGR. Supported: Normally Close Contact or Normally Open Contact.
4	On-Grid Mode	Reconnect to the utility grid manually or automatically when the inverter is restarting due to remote shutdown.
5	Enable Delay Start	Set Enable Delay Start when the On-grid Mode is Automatic . The automatic on-grid connection will be delayed after the OVGR restores to the initial contact status.
6	Recover to On-Grid Mode	If the On-grid Mode is Manual , click Recover to On-grid Mode to reconnect to the utility grid. If the On-grid Mode is Automatic , the inverter will reconnect to the utility grid automatically after the OVGR restores to the initial contact status.
RPR		
7	RPR Switch	Enable or disable the RPR function.

8	Access Port	Select the actual port on the EzLogger to which the RPR is connected. Supported: DI1, DI2, DI3, DI4.
9	PRR Contact Initial Status	Set the initial status of RPR. Supported: Normally Close Contact or Normally Open Contact.
10	On-Grid Mode	Reconnect to the utility grid manually or automatically when the inverter is restarting due to remote shutdown.
11	Enable Delay Start	Set Enable Delay Start when the On-grid Mode is Automatic . The automatic on-grid connection will be delayed after the RPR restores to the initial contact status.
12	Recover to On-Grid Mode	If the On-grid Mode is Manual , click Recover to On-grid Mode to reconnect to the utility grid. If the On-grid Mode is Automatic , the inverter will reconnect to the utility grid automatically after the RPR restores to the initial contact status.

9.6. 2 Set Remote Shutdown

The standards of some countries and regions require that a remote shutdown device should be connected to the **AI1+** or **AI2+** port and **12V Output port** of the EzLogger to realize remote shutdown function.

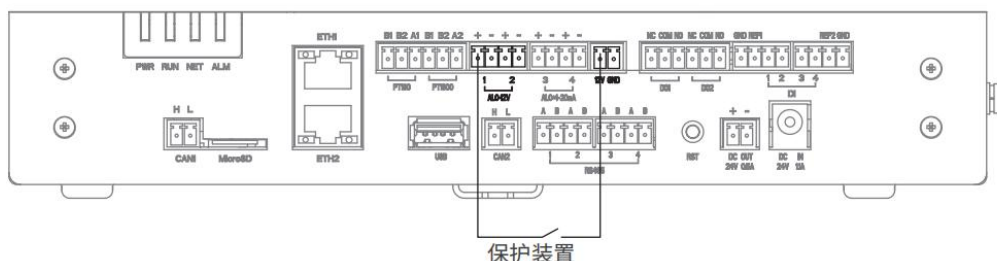

Step 1 Click **Device Maintenance > Port Setting > Remote shutdown** to set the parameters.

Step 2 Set remote shutdown and port status based on actual needs.

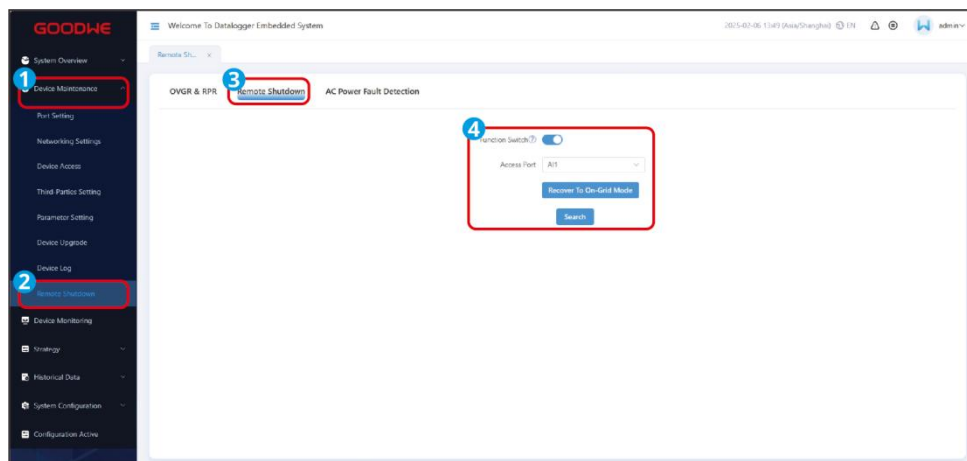

No.	Parameter	Description
1	Function Switch	Enable or disable remote shutdown function.
2	Access Port	Select the actual port on the EzLogger to which the remote shutdown device is connected. Supported: AI1 or AI2.
3	Recover to On-Grid Mode	If the the inverter is powered off, click Recover to On-Grid Mode to restart and reconnect the inverter to the utility grid.

9.6.3 Set AC Power Fault Detection

The standards of Japan and some other regions require that the inverter must not be connected to the grid when AC electricity of on-grid point is abnormal. Connect external AC fault detection device to any DI port of the controller for abnormality detection of on-grid point AC electricity.

Step 1 Click **Device Maintenance > Port Setting > AC Power Fault Detection** to set the parameters.

Step 2 Set remote shutdown and port status based on actual needs.

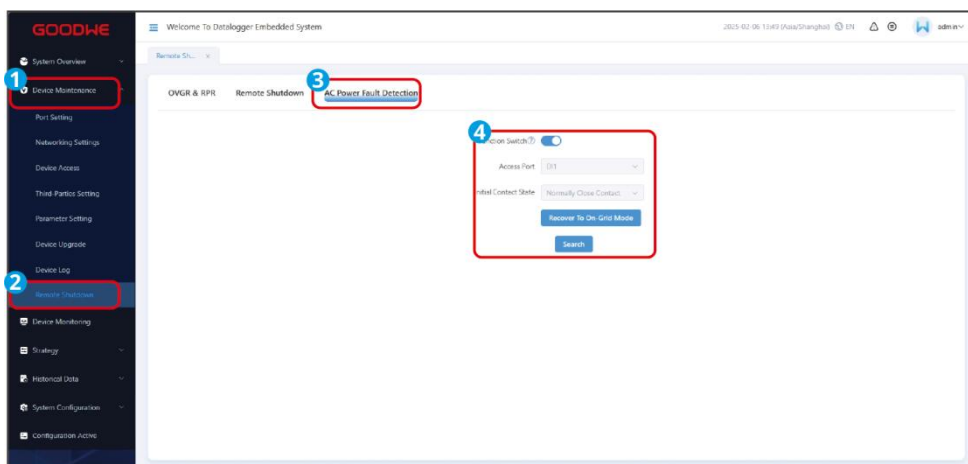

No.	Parameter	Description
1	Function Switch	Enable or disable function.
2	Access Port	Select the actual port on the EzLogger to which the remote shutdown device is connected. Supported: DI1, DI2, DI3, DI4.
3	Initial Contact State	Set the initial status of the port. Supported: Normally Close Contact or Normally Open Contact.
4	Recover to On-grid Mode	If the the inverter is in off-grid mode, click Recover to On-Grid Mode to restart and reconnect the inverter to the utility grid.

9.7 Set Strategy

9.7.1 Set Operation Mode Parameters

NOTICE

Currently only support setting the working mode of **hybrid inverters**. Default working mode: Self use mode.

Step 1 Go to **Strategy > Working Mode Configuration** to set the parameters.

Step 2 Click the inverter SN that you want to view or configure, click **Working Mode Reading** for the current working mode of **hybrid inverters**.

Step 3 Click **Working Mode Configuration**, and set the working mode of **hybrid inverters** based on actual needs.

Step 4 After setting completes, click **Device Takes Effect** to finish configuration.

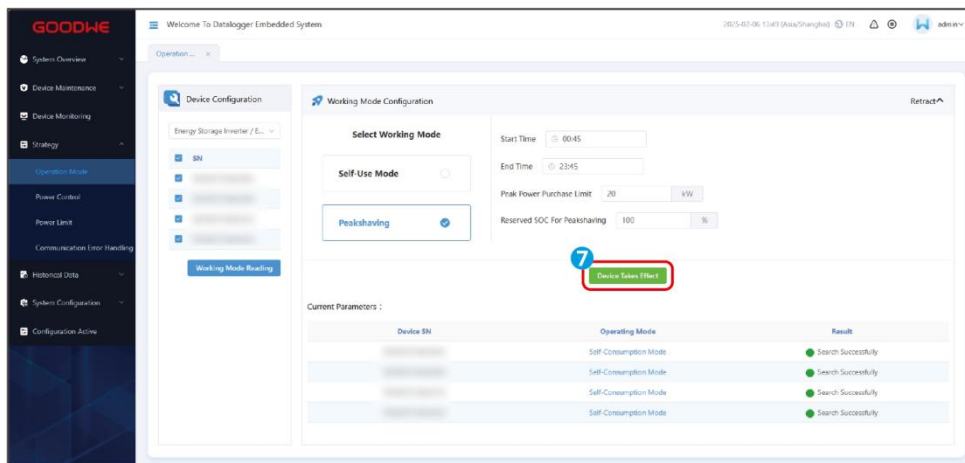
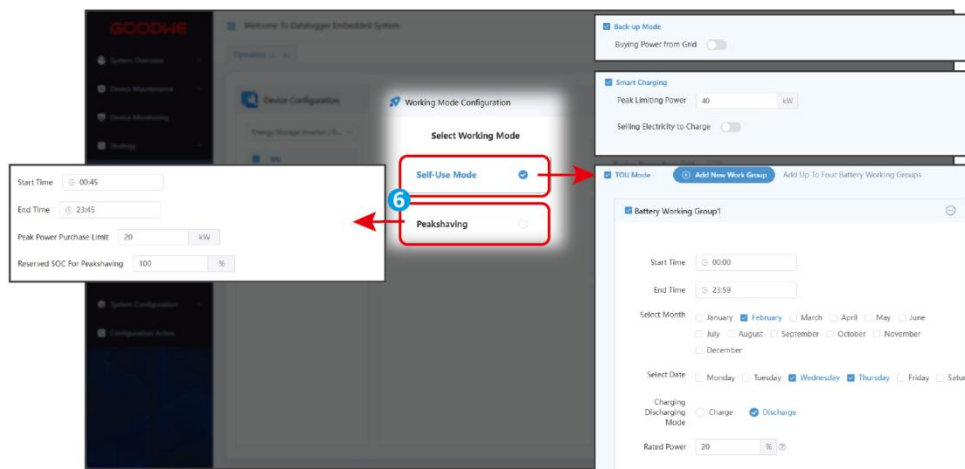
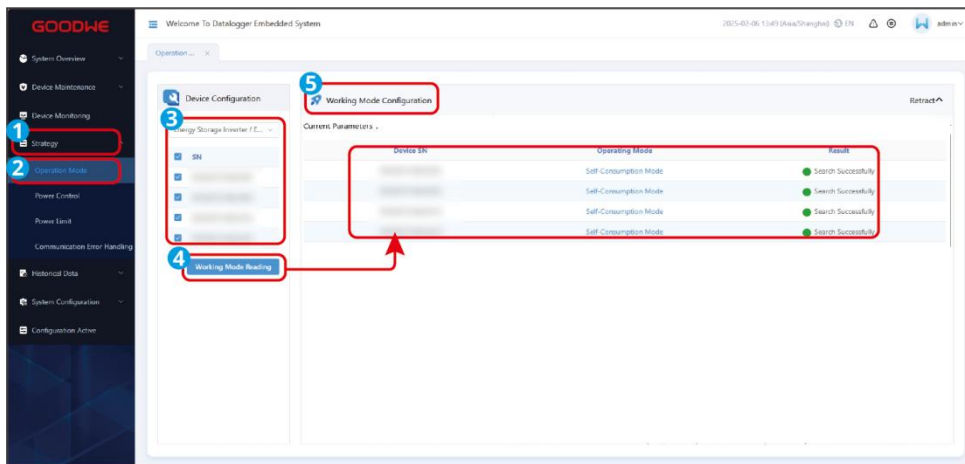

Parameter	Description
Self-use mode:	When setting this working mode, on the basis of self-use mode, back-up mode, economic mode, and smart charging mode can be enabled at the same time. Priority: Back-up mode > Economic mode > Smart charging mode > Self-use mode.
Back-up mode:	The back-up mode is mainly applied to the scenario where the grid is unstable. When the grid is disconnected, the inverter turns to off-grid mode and the battery will supply power to the load; when the grid is restored, the inverter switches to grid-tied mode.
Buying power from	Enable this function to allow the system to import electricity from the

grid	grid.
Rated Power	The percentage of the purchasing power to the rated power of the inverter.
Smart charging: In some countries/regions, the PV power feed into the utility grid is limited. Select Smart Charging to charge the battery using the surplus power to minimize PV power waste.	
Peak Limiting Power	Set the Peak Limiting Power in compliance with local laws and regulations. The Peak Limiting Power shall be lower than the output power limit specified by local requirements.
Selling Electricity to Charge	During Charging time, the PV power will charge the battery.
PV power generation peak time	Set the power generation peak period according to PV power generation.
Smart Charging Month	Set the smart charging months. More than one month can be set.
TOU mode: it is recommended to use economic mode in scenarios when the peak-valley electricity price varies a lot. Select Economic mode only when it meets the local laws and regulations. Based on actual needs, set the battery to charge mode during Vally period to charge battery with grid power;set the battery to discharge mode during Peak period to power the load with the battery.	
Start Time	Within the Start Time and End Time, the battery is charged or discharged according to the set Battery Mode as well as the Rated Power.
End Time	
Choose Month	Set the smart charging months. More than one month can be set.
Choose Date	Set the smart charging dates. More than one date can be set.
Charging Discharging Mode	Set as charge/discharge based on actual needs.
Rated Power	The percentage of the charging/discharging power to the rated power of the inverter.
Peak shaving mode: Peak shaving mode is mainly applicable to peak power limited scenarios. When the total power consumption of the load exceeds the power consumption quota in a short period of time, battery discharge can be used to reduce the power exceeding the quota.	
Start Time	The utility grid will charge the battery between Start Time and End Time if the load power consumption do not exceed the power quota. Otherwise, only PV power can be used to charge the battery.
End Time	
Peak Power Purchase Limit	Set the maximum power limit allowed to purchase from the grid. When the loads consume power exceed the sum of the power generated in the



	PV system and Import Power Limit, the excess power will be made up by the battery.
Reserved SOC For Peakshaving	In Peak Shaving mode, the battery SOC should be lower than Reserved SOC For Peakshaving. Once the battery SOC is higher than Reserved SOC For Peakshaving, the peak shaving mode fails.

9.7.2 Set Power Control

- The standards of German and other regions require that the inverter must provide signal controlling port for RCR (Ripple Control Receiver), which can be used for grid scheduling.
- To implement the RCR function, connect the RCR device to the DI1/DI2/DI3/DI4/REF1 ports of the built-in data collector in the control box to achieve active power derating, or connect it to the DI1/DI2/DI3/DI4/REF2 ports to achieve reactive power dispatching.

Step 1 Go to **Strategy > Power Control** to set the parameters.

Step 2 Set the RCR parameters based on actual needs.

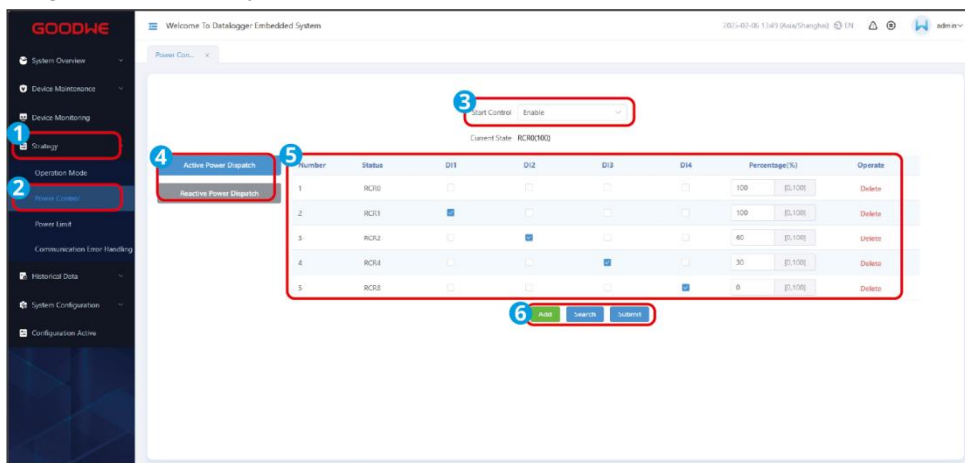

No.	Parameter	Description
1	Start Control	Enable or disable RCR function.
2	Current Status	<ul style="list-style-type: none"> ● Indicates current RCR running status. For instance, RCR1 (100) represents the operating state as RCR1, with the feeder power at 100% of the rated power. ● nRCR means the operating state is not effective.
3	Active Power Dispatch	<ul style="list-style-type: none"> ● Select one or more DI ports based on the requirements of the grid company and the type of RCR fixture, and set the corresponding percentage. The percentage refers to the system output power as a percentage of the rated power. ● Support for configuring 16 percentage levels. Set according to the actual needs of the grid company. ● Do not repeat the state combinations of DI1-DI4. Otherwise the function will not execute properly.

		<ul style="list-style-type: none"> ● If the actual wiring of the connected DI port does not match the web configuration, the operating state will not be effective.
4	Reactive Power Dispatch	<ul style="list-style-type: none"> ● Select one or more DI ports based on the requirements of the grid company and the type of RCR fixture, and set the corresponding PF value. ● Support for configuring 16 power factor levels. Set according to the actual needs of the grid company. ● The PF value range is required to be: [-100, -80] or [80, 100]. [-100, -80] corresponds to a lagging power factor between [-0.99, -0.8], and [80, 100] corresponds to a leading power factor between [0.8, 1]. ● Do not repeat the state combinations of DI1-DI4. Otherwise the function will not execute properly. ● If the actual wiring of the connected DI port does not match the web configuration, the operating state will not be effective.

9.7.3 Set Power Limit

If the power generated by the PV system cannot be consumed by loads, the remaining power will be fed into the utility grid. Control the power fed into the grid by setting the **Power Limit** parameters.

Step 1 Go to **Strategy > Power Limit** to set the parameters.

Step 2 Set **Power Limit** parameters based on actual needs.

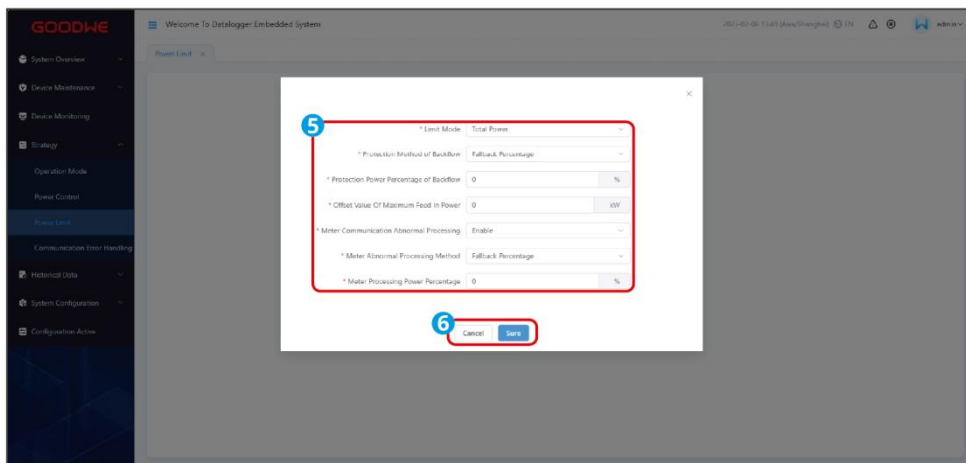
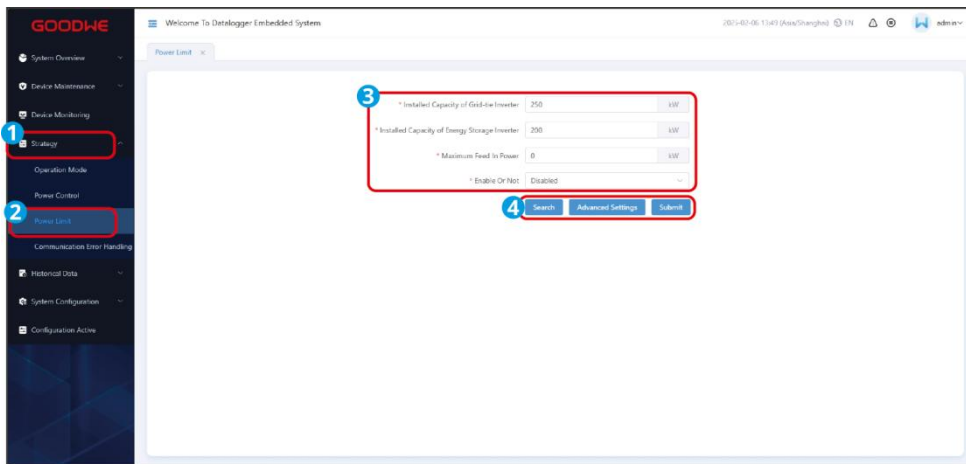

No.	Parameter	Description
1	Installed Capacity of Grid-tied Inverter	Set the total capacity of all grid-tied inverters in the system.
2	Installed Capacity of Hybrid Inverter	Set the total capacity of hybrid inverters in the system.
3	Maximum Feed In Power	Set the maximum power that is allowed to be fed into the utility grid based on local grid standards and requirements.
4	Enable or not	Enable or not Power Limit.
5	Limit Mode	Select the output power control mode based on actual situation. <ul style="list-style-type: none"> Total Power: controls the total power at the grid-connection point to limit the power fed to the power grid. Each Phase Power: controls the power of each phase at the grid-connection point to limit the power fed to the power grid.
6	Protection Method of Backflow	The power feed into the utility grid is allowed to exceed the limit value within a specified duration(5s by default)The following measures can be taken when output power exceeds the limit value more than the maximum allowed time: <ul style="list-style-type: none"> Power Percentage: the equipment continues to work at the

		percentage of the rated power. ● Device Offline: stop the equipment.
7	Protection Power Percentage of Backflow	The equipment continues to work at the percentage of the rated power.
8	Offset Value Of Maximum Feed In Power	<ul style="list-style-type: none"> ● Set the adjustable range of the maximum power to be exported to the utility grid. ● Maximum power exported to the utility grid = maximum feed in power + offset value of maximum feed in power.
9	Meter Communication Abnormal Processing	After enabling, protection methods will be taken when abnormalities occur in communication between the smart meter and the EzLogger.
10	Meter Abnormal Processing Method	<p>The protective measures will be taken when exception occurs in smart meter communication:</p> <ul style="list-style-type: none"> ● Power Limit: the equipment continues to work at the percentage of the rated power. ● Device Offline: stop the equipment.
11	Meter Processing Power Percentage	The equipment continues to work at the percentage of the rated power.

9.7.4 Set Communication Error Handling

Step 1 Go to **Strategy > Communication Error Handling** to set the parameters.

Step 2 Set the communication parameters based on actual needs.

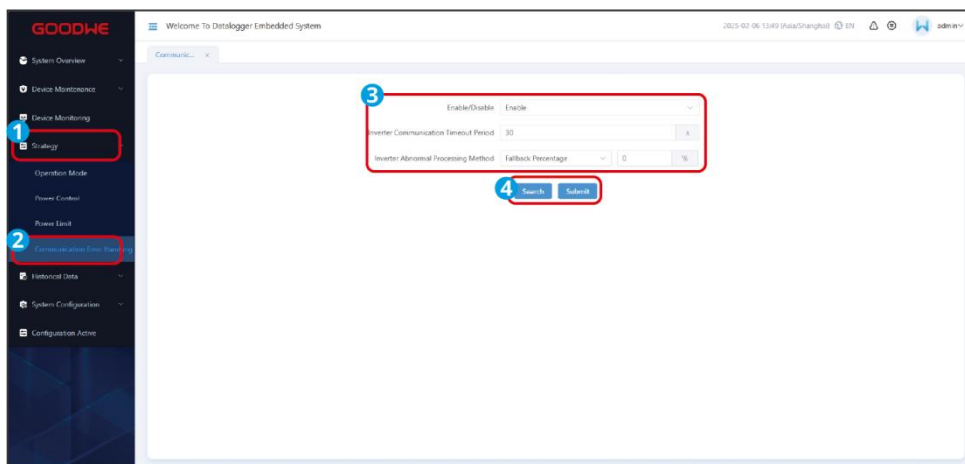

No.	Parameter	Description
1	Enable/Disable	After enabling, protection methods will be taken when exception

		occurs in communication between the inverter and the controller.
2	Inverter Communication Timeout Period	The protective measures will be taken when communication exception time exceeds the set time.
3	Inverter abnormal processing method	<p>After enabling, protection methods will be taken when exceptions occur in communication between the inverter and the controller:</p> <ul style="list-style-type: none"> ● Power Limit: the equipment continues to work at the percentage of the rated power. ● Device Offline: stop the equipment.

10 Maintenance

10.1 System Power OFF



- Power off the controller before operations and maintenance. Otherwise, the controller may be damaged or electric shocks may occur.
- After being powered off, a period of time is required for the internal components to discharge. Wait until the equipment is completely discharged according to the label time.

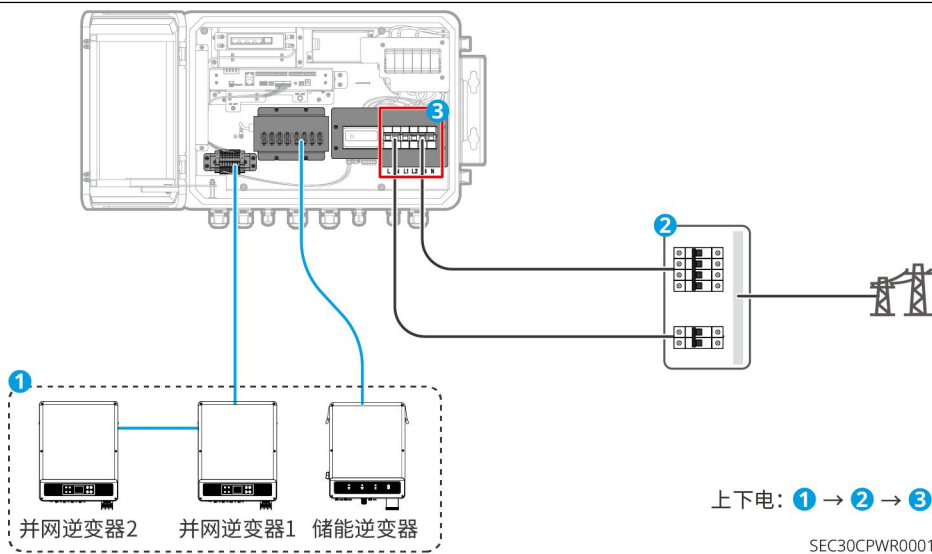

10.2 Remove the Equipment



- Make sure that the equipment is powered off.
- Wear proper personal protective equipment before any operations.

Step 1 Disconnect all electrical connections of the equipment, including the power cable and communication cables.

Step 2 Remove the equipment.

Step 3 Store the equipment properly. If the equipment will be used again in the future, ensure that the storage conditions meet the requirements.

10.3 Dispose of the Equipment

If the equipment cannot work any more, dispose of it according to the local disposal requirements for electrical equipment waste. Do not dispose of it as household waste.

10.4 Maintenance



WARNING

- Contact after-sales service for help if there are problems affecting batteries or hybrid inverters. Do not touch or disassemble privately.
- Contact after-sales service for help if the copper conductor is exposed. Do not touch or disassemble privately because high voltage danger exists.
- In case of other emergencies, contact the after-sales service as soon as possible. Operate following the instructions or wait for the after-sales service personnel.

Maintaining Item	Maintaining Method	Maintaining Routine	Maintaining Purpose
System Cleaning	<ol style="list-style-type: none"> 1. Check if there are foreign objects and dust in air inlet/outlet port. 2. Check if the installation space meets requirements and if there is any debris around the device. 	Once 6 months	Prevent heat dissipation failures.
System Installation	<ol style="list-style-type: none"> 1. Check if the equipment is installed securely and whether the screws are installed tightly. 2. Check if the equipment is damaged or deformed. 	Once 6 months or once a year	Ensure that the equipment is installed securely.
Electrical connection	<p>Check whether the cables are securely connected.</p> <p>Check whether the cables are broken or whether there is any exposed copper core.</p>	Once 6 months or once a year	Ensure the reliability of electrical connection.
Sealing	<p>Check if all the terminals and ports are properly sealed. Reseal the cable hole if it is not sealed or too big.</p>	Once a year	Confirm that the machine seal and waterproof performance are intact.



10.5 System Maintenance (WEB)

10.5.1 Upgrading

NOTICE

Ensure that the device is powered on during the upgrade. Otherwise, the upgrade may fail.

Upgrading via USB flash drive (only for EzLogger)

NOTICE

Before upgrading, make sure only the upgrading package is stored in the USB flash drive. If there are multiple upgrading packages, the system reads the first upgrading package by default, and this may lead to upgrading failure.

Step 1 Obtain the upgrading package from after-sales service and prepare a FAT32 USB flash drive ($\leq 32G$).

Step 2 Create a new folder named collector in the root directory of the USB flash drive. Put the upgrade folder into the collector folder.

Step 3 Insert the USB flash drive into the USB port of the EzLogger. The fault indicator turns to fast blinking after the EzLogger detects the firmware package and starts upgrading. If the fault indicator does not blink fast, check whether the firmware package and USB flash drive are in proper state.

Step 4 The EzLogger will restart automatically after upgrading. Plug out the USB flash drive, or repeated upgrades may occur.

Upgrading via Web

Step 1 Obtain the firmware package from after-sales service.

Step 2 Save the firmware package to the PC and upgrade the device as following.

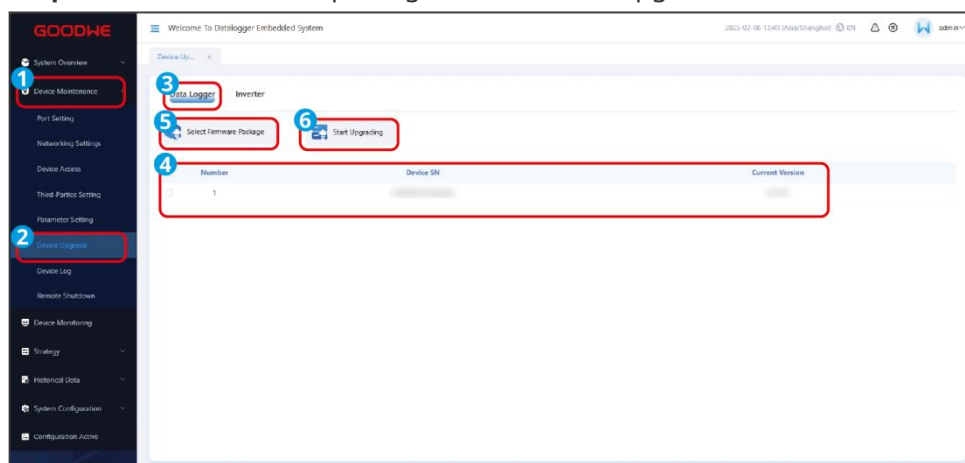

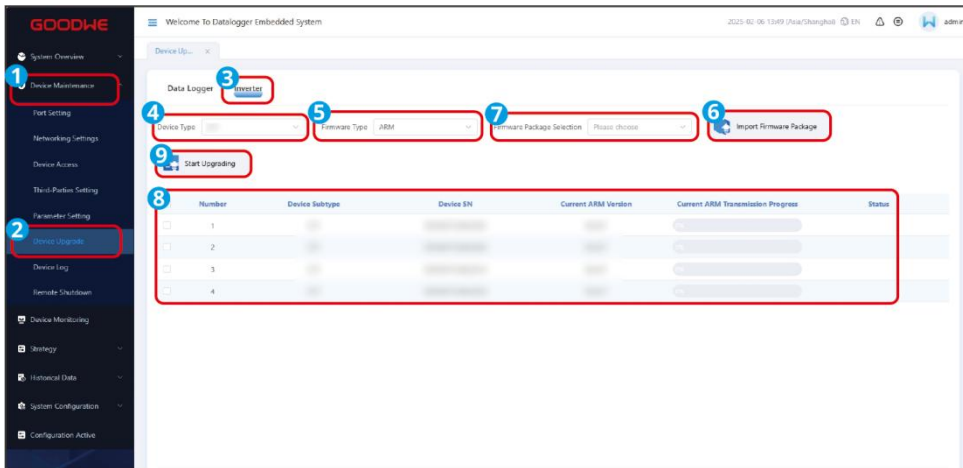

10.5.2 Maintaining the System



No.	Parameter	Description
1	Reset Logger	Perform a system reset, and the EzLogger will automatically shut down and restart.
2	Restore Factory Settings	After restoring the factory settings, all previously set parameter values (except for the current date, time, and communication parameters) will return to their default factory settings. Operating information, alarm records, and system logs will remain unchanged. Please proceed with caution.
3	Import All Configuration Files	Before replacing the controller or the in-built EzLogger, export the configuration file to the local storage.
4	Export All Configuration Files	After replacing the controller or the in-built EzLogger, import the previously exported configuration file from the local storage to the new controller or in-built EzLogger. Once the import is successful, the EzLogger will restart, and the configuration file will take effect. Confirm that the device parameters are correctly configured.
5	Start Guide	Click to go to Start Guide.



10.5.3 Set System Time

NOTICE

Modifying the date and time will affect the integrity of the system's power generation and performance data records. Please refrain from changing the time zone and system time arbitrarily.

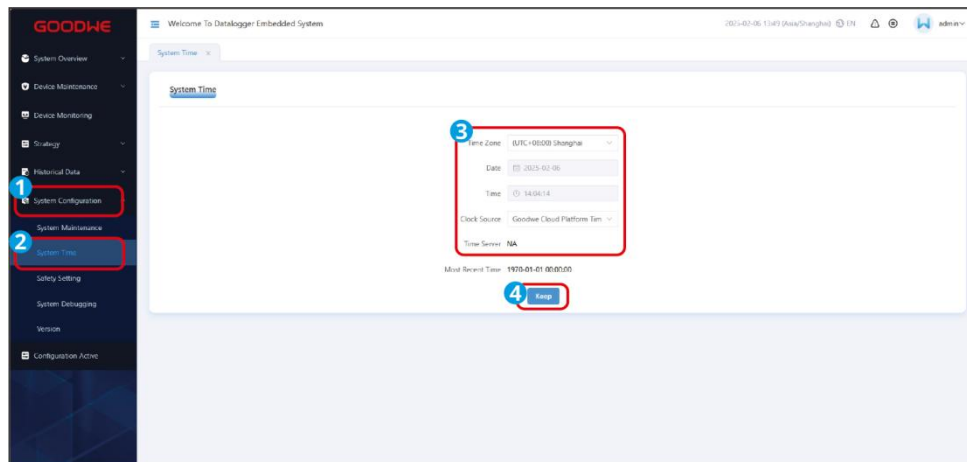

No.	Parameter	Description
1	Time Zone	The parameters can be manually modified only when Management System is selected as Clock Source .
2	Date	
3	Time	
4	Clock Source	Set Clock Source Supported: NTP, IEC104, Modbus-TCP, Management System, Goodwe Cloud Platform Time Synchronization.

10.5.4 Change Login Password

Step 1 Go to **Logger Configuration > Safety Setting** to modify password.

Step 2 Click **Modify Password**, and input old and new passwords and save.

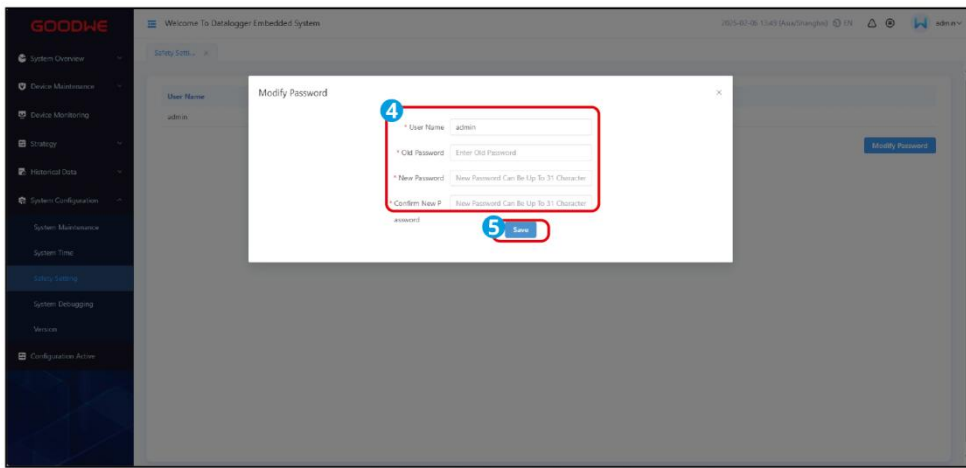
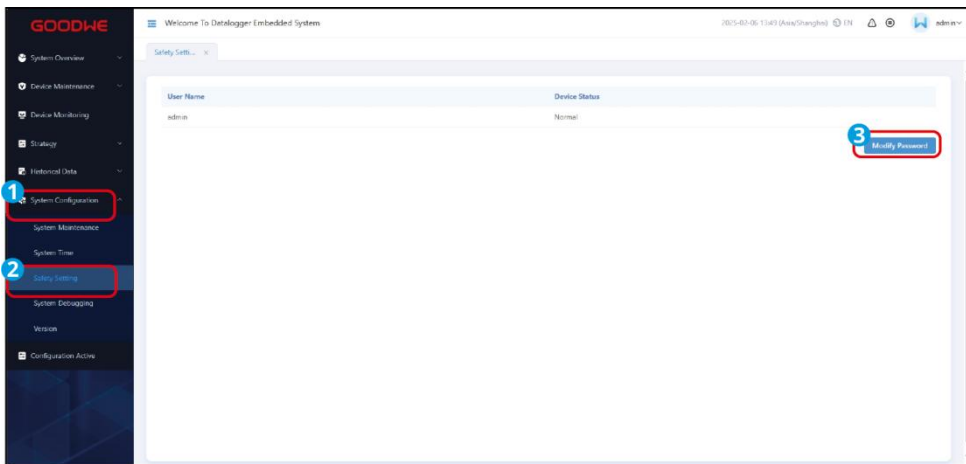

10.6 Fault

Perform troubleshooting according to the following methods. Contact the after-sales service if these methods do not work.

Collect the information below before contacting the after-sales service, so that the problems can be solved quickly.

1. Product information like serial number, software version, installation date, fault time, fault frequency, etc.
2. Installation environment, including weather conditions, whether the PV modules are sheltered or shadowed, etc. It is recommended to provide some photos and videos to assist in analyzing the problem.
3. Utility grid situation.

No.	Fault	Solutions
1	Data logger indicator not lit after being powered on.	<ol style="list-style-type: none"> 1. Check if the SEC3000C in-built single-phase circuit breaker has voltage (voltage range : 100 Vac - 240 Vac). 2. Check if the single-phase circuit breaker is switched on.
2	Meter indicator not lit after being powered on.	<ol style="list-style-type: none"> 1. Three-phase four wire system: Check the SEC3000C in-built three-phase circuit breaker.

		<p>Line voltage range:156 Vac - 480 Vac.</p> <ol style="list-style-type: none"> 2. Three-phase three wire system: Check the SEC3000C in-built three-phase circuit breaker. Line voltage range:156 Vac - 480 Vac. 3. Check if the three-phase circuit breaker is switched on.
3	Unable to load the Web page.	<ol style="list-style-type: none"> 1. Check if web page is visited 1 minute later after the equipment is powered on. 2. Check if the equipment is correctly connected with and PC via network cables. 3. Check if the IP address setting is modified to 172.18.0.XXX or automatic access. 4. Clear the cache of the browser page.
4	The equipment is offline on the Web page.	<ol style="list-style-type: none"> 1. Check if the hybrid inverter is connected to in-built switch's network port via WiFi/ LAN Kit-20. 2. Check if the inverter is correctly connected to the RS485 communication terminal of the SEC3000C.
5	Smart meter displays abnormal data.	<ol style="list-style-type: none"> 1. Check if the CT ratio setting in the web interface matches the actual CT ratio in use. 2. Check if the CT wiring is correct. 3. Three-phase four wire system: check if the wiring sequence (N/L1/L2/L3) of the SEC3000C in-built three-phase circuit breaker is correct. 4. Three-phase three wire system: check the SEC3000C in-built three-phase circuit breaker to make sure whether L2 and the neutral (N) cable are short circuited, and whether the wiring sequence (/L1/L2/L3) is correct.



11 Technical Parameters

Model	SEC3000C
Communication	
Max. Inverters Supported	RS485: 60, LAN*1: 10
RS485 interface	4
Ethernet	2*RJ45, 10/100Mbps
4G	Optional
Digital/Analog Input/Output	DI×4, DO×2, AI×4
Configuration	
Datalogger	EzLogger3000C*1
Switth	15 Ports
Smart Meter	GM330*1
Meter Voltage Measurement Range (Vac)	3L/N/PE: 172~817 (line voltage) 3L/PE: 100~472 (line voltage)
Meter Frequency Measurement Range (Hz)	50/60
Meter Current Measurement Range	nA:5A (200≤n≤5000)
Power Supply	100~240V, 50/60Hz
Power Consumption (W)	≤25
Mechanical	
Dimensions (W×H×D mm)	575*400*242
Weight (kg)	≤14
Installation Method	Wall mounting, bracket mounting, pole mounting
Environment	
Operating Temperature Range (°C)	-30~+60
Storage Temperature Range (°C)	-40~+70
Relative Humidity	0~95%(non-condensing)
Max. Operating Altitude (m)	3000
Ingress Protection Rating	IP65
Anti-corrosion Class	C5M

12 Appendix

12.1 Abbreviation

Abbreviation	English
U_{batt}	Battery Voltage Range
$U_{batt,r}$	Nominal Battery Voltage
$I_{batt,max (C/D)}$	Max. Continuous Charging Current Max. Continuous Discharging Current
$E_{C,R}$	Rated Energy
U_{DCmax}	Max. Input Voltage
U_{MPP}	MPPT Operating Voltage Range
$I_{DC,max}$	Max. Input Current per MPPT
$I_{SC PV}$	Max. Short Circuit Current per MPPT
$P_{AC,r}$	Nominal Output Power
$S_r (to grid)$	Nominal Apparent Power Output to Utility Grid
$S_{max (to grid)}$	Max. Apparent Power Output to Utility Grid
$S_r (from grid)$	Nominal Apparent Power from Utility Grid
$S_{max (from grid)}$	Max. Apparent Power from Utility Grid
$U_{AC,r}$	Nominal Output Voltage
$f_{AC,r}$	Nominal AC Grid Frequency
$I_{AC,max(to grid)}$	Max. AC Current Output to Utility Grid
$I_{AC,max(from grid)}$	Max. AC Current From Utility Grid
P.F.	Power Factor
S_r	Back-up Nominal apparent power
S_{max}	Max. Output Apparent Power (VA) Max. Output Apparent Power without Grid
$I_{AC,max}$	Max. Output Current
$U_{AC,r}$	Nominal Output Voltage
$f_{AC,r}$	Nominal Output Frequency
$T_{operating}$	Operating Temperature Range
$I_{DC,max}$	Max. Input Current
U_{DC}	Input Voltage
$U_{DC,r}$	DC Power Supply
U_{AC}	Power Supply/AC Power Supply
$U_{AC,r}$	Power Supply/Input Voltage Range

$T_{\text{operating}}$	Operating Temperature Range
P_{max}	Max Output Power
P_{RF}	TX Power
P_{D}	Power Consumption
$P_{\text{AC,r}}$	Power Consumption
$F_{\text{(Hz)}}$	Frequency
$I_{\text{SC PV}}$	Max. Input Short Circuit Current
$U_{\text{dcmin}}-U_{\text{dcmax}}$	Range of input Operating Voltage
$U_{\text{AC,rang(L-N)}}$	Power Supply Input Voltage
$U_{\text{sys,max}}$	Max System Voltage
$H_{\text{altitude,max}}$	Max. Operating Altitude
PF	Power Factor
THDi	Total Harmonic Distortion of Current
THDv	Total Harmonic Distortion of Voltage
C&I	Commercial & Industrial
SEMS	Smart Energy Management System
MPPT	Maximum Power Point Tracking
PID	Potential-Induced Degradation
Voc	Open-Circuit Voltage
Anti PID	Anti-PID
PID Recovery	PID Recovery
PLC	Power-line Communication
Modbus TCP/IP	Modbus Transmission Control / Internet Protocol
Modbus RTU	Modbus Remote Terminal Unit
SCR	Short-Circuit Ratio
UPS	Uninterruptible Power Supply
ECO mode	Economical Mode
TOU	Time of Use
ESS	Energy Storage System
PCS	Power Conversion System
SPD	Surge Protection Device
DRED	Demand Response Enabling Device
RCR	Ripple Control Receiver
AFCI	AFCI
GFCI	Ground Fault Circuit Interrupter
RCMU	Residual Current Monitoring Unit



FRT	Fault Ride Through
HVRT	High Voltage Ride Through
LVRT	Low Voltage Ride Through
EMS	Energy Management System
BMS	Battery Management System
BMU	Battery Measure Unit
BCU	Battery Control Unit
SOC	State of Charge
SOH	State of Health
SOE	State Of Energy
SOP	State Of Power
SOF	State Of Function
SOS	State Of Safety
DOD	Depth of discharge

12.2 Terminology Explanation

Explanation of Overvoltage Categories

Overvoltage I : Equipment connected to circuits with measures limiting the transient overvoltage to a very low level.

Overvoltage II : Energy-consuming equipment supplied by a fixed installation. This category includes appliances, portable tools, and other household or similar loads. If specific reliability and suitability requirements apply to such equipment, Overvoltage III should be used instead.

Overvoltage III : Equipment within fixed installations in which reliability and suitability must meet special requirements. This includes switching devices within fixed installations and industrial equipment permanently connected to fixed installations.

Overvoltage IV : Equipment used at the power supply side of the distribution system. This includes measuring instruments and upstream overcurrent protection devices.

Explanation of Moist Scenarios Categories

Environment parameter	Level		
	3K3	4K2	4K4H
Humidity range	0~+40°C	-33~+40°C	-33~+40°C
Temperature range	5% - 85%	15% - 100%	4% - 100%

Explanation of Environment Categories :

Outdoor inverter: ambient temperature (-25~+60 °C) , suitable for environments with pollution degree 3.

Indoor inverter II :ambient temperature (-25~+40 °C) , suitable for environments with pollution degree 3.

Indoor inverter I :ambient temperature (0~+40 °C) , suitable for environments with pollution degree 2.

Explanation of Pollution Degree Categories

Pollution degree 1: No pollution or only dry, non-conductive pollution.

Pollution degree 2: Generally, only non-conductive pollution, but occasional short-term conductive pollution due to condensation must be considered.

Pollution degree 3: Conducive pollution or non-conductive pollution that becomes conducive due to condensation.

Pollution degree 4: Persistent conducive pollution, such as pollution caused by conducive dust or rain and snow.